

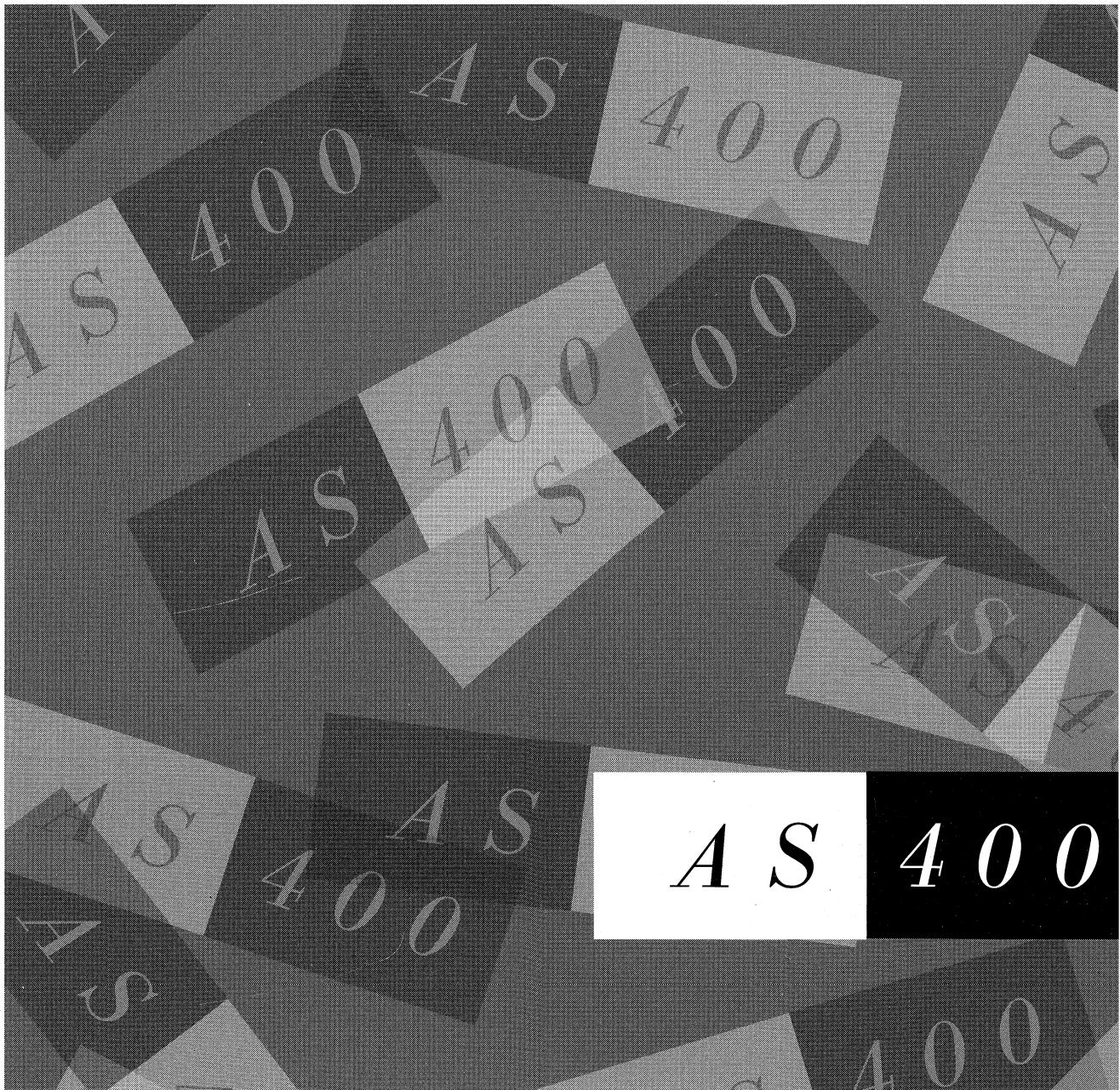

AS/400 Integrated Language Environment Concepts

Version 3





AS/400

SC41-3606-00

Integrated Language Environment Concepts

Version 3

Take Note!

Before using this information and the product it supports, be sure to read the general information under "Notices" on page vii.

First Edition (September 1994)

This edition applies to the licensed program IBM Operating System/400, (Program 5763-SS1), Version 3 Release 1 Modification 0, and to all subsequent releases and modifications until otherwise indicated in new editions. Make sure you are using the proper edition for the level of the product.

Order publications through your IBM representative or the IBM branch serving your locality. If you live in the United States, Puerto Rico, or Guam, you can order publications through the IBM Software Manufacturing Company at 800+879-2755. Publications are not stocked at the address given below.

A form for reader comments is provided at the back of this publication. If the form has been removed, you can mail your comments to:

Attn Department 245
IBM Corporation
3605 Highway 52 N
Rochester, MN 55901-9986 USA

or you can fax your comments to:

United States and Canada: 800+937-3430
Other countries: (+1)+507+253-5192

If you have access to Internet, you can send your comments electronically to *idclerk@rchvmw2.vnet.ibm.com*; IBMMAIL, to *ibmmail(usib56rz)*.

When you send information to IBM, you grant IBM a non-exclusive right to use or distribute the information in any way it believes appropriate without incurring any obligation to you or restricting your use of it.

© **Copyright International Business Machines Corporation 1994. All rights reserved.**

Note to U.S. Government Users — Documentation related to restricted rights — Use, duplication or disclosure is subject to restrictions set forth in GSA ADP Schedule Contract with IBM Corp.

Contents

Notices	vii
Programming Interface Information	vii
Trademarks and Service Marks	viii
About ILE Concepts, SC41-3606	ix
Who Should Use This Book	ix
Chapter 1. Integrated Language Environment Introduction	1-1
What Is ILE?	1-1
What Are the Benefits of ILE?	1-1
Binding	1-1
Modularity	1-1
Reusable Components	1-2
Common Run-Time Services	1-2
Coexistence with Existing Applications	1-3
Source Debugger	1-3
Better Control over Resources	1-3
Better Control over Language Interactions	1-4
Better Code Optimization	1-6
Better Environment for C	1-6
Foundation for the Future	1-6
What Is the History of ILE?	1-6
Original Program Model Description	1-7
Extended Program Model Description	1-8
Integrated Language Environment Description	1-10
Chapter 2. ILE Basic Concepts	2-1
Structure of an ILE Program	2-1
Procedure	2-2
Module Object	2-2
ILE Program	2-3
Service Program	2-5
Binding Directory	2-7
Binder Functions	2-8
Calls to Programs and Procedures	2-10
Dynamic Program Calls	2-10
Static Procedure Calls	2-10
Activation	2-12
Error Handling	2-13
Optimizing Translator	2-14
Debugger	2-15
Chapter 3. ILE Advanced Concepts	3-1
Program Activation	3-1
Program Activation Creation	3-2
Activation Group	3-3
Activation Group Creation	3-4
Default Activation Groups	3-5
ILE Activation Group Deletion	3-6
Service Program Activation	3-8

Control Boundaries	3-10
Control Boundaries for ILE Activation Groups	3-10
Control Boundaries for the OPM Default Activation Group	3-11
Control Boundary Use	3-11
Error Handling	3-12
Job Message Queues	3-12
Exception Messages and How They Are Sent	3-13
How Exception Messages Are Handled	3-14
Exception Recovery	3-14
Default Actions for Unhandled Exceptions	3-14
Types of Exception Handlers	3-16
ILE Conditions	3-19
Data Management Scoping Rules	3-19
Call-Level Scoping	3-20
Activation-Group-Level Scoping	3-20
Job-Level Scoping	3-21
Chapter 4. Program Creation Concepts	4-1
Create Program and Create Service Program Commands	4-1
Symbol Resolution	4-2
Resolved and Unresolved Imports	4-2
Binding by Copy	4-3
Binding by Reference	4-3
Importance of the Order of Exports	4-3
Program Access	4-8
Entry Module Parameter on the CRTPGM Command	4-8
Export Parameter on the CRTSRVPGM Command	4-9
Binder Language	4-10
Signature	4-11
Start Program Export and End Program Export Commands	4-12
Export Symbol Command	4-13
Binder Language Examples	4-13
Program Updates	4-22
Important Parameters on the UPDPM and UPDSRVPGM Commands	4-23
Module Replaced by a Module with Fewer Imports	4-24
Module Replaced by a Module with More Imports	4-24
Module Replaced by a Module with Fewer Exports	4-24
Module Replaced by a Module with More Exports	4-25
Tips for Creating Modules, Programs, and Service Programs	4-25
Chapter 5. Activation Group Management	5-1
Multiple Applications Running in the Same Job	5-1
Reclaim Resources Command	5-2
Reclaim Resources Command for OPM Programs	5-4
Reclaim Resources Command for ILE Programs	5-4
Reclaim Activation Group Command	5-4
Service Programs and Activation Groups	5-4
Chapter 6. Calls to Procedures and Programs	6-1
Call Stack	6-1
Call Stack Example	6-1
Calls to Programs and Calls to Procedures	6-2
Static Procedure Calls	6-3
Procedure Pointer Calls	6-3

Passing Arguments to ILE Procedures	6-3
Dynamic Program Calls	6-5
Passing Arguments on a Dynamic Program Call	6-6
Interlanguage Data Compatibility	6-6
Syntax for Passing Arguments in Mixed-Language Applications	6-6
Operational Descriptors	6-6
Support for OPM and ILE APIs	6-8
Chapter 7. Storage Management	7-1
Dynamic Storage	7-1
Heap Characteristics	7-1
Default Heap	7-2
User-Created Heaps	7-2
ILE C/400 Heap Support	7-3
Heap Allocation Strategy	7-4
Storage Management Bindable APIs	7-4
Chapter 8. Exception and Condition Management	8-1
Handle Cursors and Resume Cursors	8-1
Exception Handler Actions	8-2
How to Resume Processing	8-3
How to Percolate a Message	8-3
How to Promote a Message	8-4
Default Actions for Unhandled Exceptions	8-4
Nested Exceptions	8-5
Condition Handling	8-5
How Conditions Are Represented	8-6
Condition Token Testing	8-8
Relationship of ILE Conditions to OS/400 Messages	8-8
OS/400 Messages and the Bindable API Feedback Code	8-9
Chapter 9. Debugging Considerations	9-1
Debug Mode	9-1
Addition of Programs to Debug Mode	9-1
How Observability and Optimization Affect Debugging	9-1
Observability	9-2
Optimization Levels	9-2
Debug Data Creation and Removal	9-2
Module Views	9-2
Debugging across Jobs	9-3
Unmonitored Exceptions	9-3
National Language Support Restriction for Debugging	9-3
Chapter 10. Data Management Scoping	10-1
Common Data Management Resources	10-1
Commitment Control Scoping	10-2
Chapter 11. ILE Bindable Application Programming Interfaces	11-1
ILE Bindable APIs Available	11-1
Dynamic Screen Manager Bindable APIs	11-4
Appendix A. Output Listing from CRTPGM, CRTSRVPGM, UPDPGM, or UPDSRVPGM Command	A-1
Binder Listing	A-1

Basic Listing	A-1
Extended Listing	A-3
Full Listing	A-5
Listing for Example Service Program	A-7
Binder Language Errors	A-9
Signature Padded	A-10
Signature Truncated	A-11
Current Export Block Limits Interface	A-12
Duplicate Export Block	A-13
Duplicate Symbol on Previous Export	A-14
Level Checking Cannot Be Disabled More than Once, Ignored	A-15
Multiple Current Export Blocks Not Allowed, Previous Assumed	A-16
Current Export Block Is Empty	A-17
Export Block Not Completed, End-of-File Found before ENDPGMEXP	A-18
Export Block Not Started, STRPGMEXP Required	A-19
Export Blocks Cannot Be Nested, ENDPGMEXP Missing	A-20
Exports Must Exist inside Export Blocks	A-21
Identical Signatures for Dissimilar Export Blocks, Must Change Exports	A-22
No Current Export Block	A-23
Previous Export Block Is Empty	A-24
Signature Contains Variant Characters	A-25
SIGNATURE(*GEN) Required with LVLCHK(*NO)	A-26
Signature Syntax Not Valid	A-27
Symbol Name Required	A-28
Symbol Not Allowed as Service Program Export	A-29
Symbol Not Defined	A-30
Syntax Not Valid	A-31
Appendix B. Optimization Errors	B-1
Appendix C. CL Commands Used with ILE Objects	C-1
CL Commands Used with Modules	C-1
CL Commands Used with Program Objects	C-1
CL Commands Used with Service Programs	C-1
CL Commands Used with Binding Directories	C-1
CL Command Used with Structured Query Language	C-2
CL Commands Used with Source Debugger	C-2
CL Commands Used to Edit the Binder Language Source File	C-2
Glossary	G-1
Bibliography	H-1
Index	X-1

Notices

References in this publication to IBM products, programs, or services do not imply that IBM intends to make these available in all countries in which IBM operates. Any reference to an IBM product, program, or service is not intended to state or imply that only that IBM product, program, or service may be used. Any functionally equivalent product, program, or service that does not infringe any of the intellectual property rights of IBM may be used instead of the IBM product, program, or service. The evaluation and verification of operation in conjunction with other products, except those expressly designated by IBM, are the responsibility of the user.

IBM may have patents or pending patent applications covering subject matter in this document. The furnishing of this document does not give you any license to these patents. You can send license inquiries, in writing, to the IBM Director of Commercial Relations, IBM Corporation, Purchase, NY 10577, U.S.A.

This publication could contain technical inaccuracies or typographical errors.

This publication may refer to products that are announced but not currently available in your country. This publication may also refer to products that have not been announced in your country. IBM makes no commitment to make available any unannounced products referred to herein. The final decision to announce any product is based on IBM's business and technical judgment.

Changes or additions to the text are indicated by a vertical line (|) to the left of the change or addition.

This publication contains small programs that are furnished by IBM as simple examples to provide an illustration. These examples have not been thoroughly tested under all conditions. IBM, therefore, cannot guarantee or imply reliability, serviceability, or function of these programs. All programs contained herein are provided to you "AS IS." THE IMPLIED WARRANTIES OF MERCHANTABILITY AND FITNESS FOR A PARTICULAR PURPOSE ARE EXPRESSLY DISCLAIMED.

If you are viewing this manual from a compact disk (CD-ROM), the photographs and color illustrations do not appear.

Programming Interface Information

This manual is intended to help you with application programming. It contains general-use programming interfaces that allow you to write programs that use the Integrated Language Environment services in the OS/400 operating system.

Trademarks and Service Marks

The following terms, denoted by an asterisk (*) in this publication, are trademarks of the IBM Corporation in the United States or other countries or both:

Application System/400	Operating System/400
AS/400	OS/2
C/400	OS/400
COBOL/400	RPG IV
DB2/400	SAA
IBM	Systems Application Architecture
ILE	400
Integrated Language Environment	
Language Environment	

The following terms, denoted by a double asterisk (**) in this publication, are trademarks of other companies:

UNIX	UNIX System Laboratories, Inc.
Windows	Microsoft Corporation

About ILE Concepts, SC41-3606

This book describes concepts and terminology pertaining to the Integrated Language Environment (ILE) architecture of the OS/400 licensed program. Topics covered include module creation, binding, the running and debugging of programs, and exception handling.

The concepts described in this book pertain to all ILE languages. Each ILE language may implement the ILE architecture somewhat differently. To determine exactly how each language enables the concepts described here, refer to the programmer's guide for that specific ILE language.

This book also describes OS/400 functions that directly pertain to all ILE languages. In particular, common information on binding, message handling, and debugging are explained.

This book does not describe migration from an existing AS/400 language to an ILE language. That information is contained in each ILE high-level language (HLL) programmer's guide.

Who Should Use This Book

You should read this book if:

- You are a software vendor developing applications or software tools
- You are experienced in developing mixed-language applications on the AS/400 system
- You are not familiar with the AS/400 system but have application programming experience on other systems
- Your programs share common procedures, and when you update or enhance those procedures, you have to re-create the programs that use them

If you are an AS/400 application programmer who writes primarily in one language, you should read the first four chapters of this book for a general understanding of ILE and its benefits. The programmer's guide for that ILE language can then be sufficient for application development.

Chapter 1. Integrated Language Environment Introduction

This chapter defines the Integrated Language Environment* (ILE*) model, describes the benefits of ILE, and explains how ILE evolved from previous program models.

Wherever possible, information is presented from the perspective of an RPG or COBOL programmer and is described in terms of existing AS/400* features.

What Is ILE?

ILE is a new set of tools and associated system support designed to enhance program development on the AS/400 system.

The capabilities of this new model can be exploited only by programs produced by the new ILE family of compilers. That family includes ILE RPG/400*, ILE COBOL/400*, ILE C/400*, and ILE CL.

What Are the Benefits of ILE?

ILE offers numerous benefits over previous program models. Those benefits include binding, modularity, reusable components, common run-time services, coexistence, and a source debugger. They also include better control over resources, better control over language interactions, better code optimization, a better environment for C, and a foundation for the future.

Binding

The benefit of binding is that it helps reduce the overhead associated with calling programs. Binding the modules together speeds up the call. The previous call mechanism is still available, but there is also a faster alternative. To differentiate between the two types of calls, the previous method is referred to as a dynamic or external program call, and the ILE method is referred to as a static or bound procedure call.

The binding capability, together with the resulting improvement in call performance, makes it far more practical to develop applications in a highly modular fashion. An ILE compiler does not produce a program that can be run. Rather, it produces a module object (*MODULE) that can be combined (bound) with other modules to form a single runnable unit; that is, a program object (*PGM).

Just as you can call an RPG program from a COBOL program, ILE allows you to bind modules written in different languages. Therefore, it is possible to create a single runnable program that consists of modules written separately in RPG, COBOL, C, and CL.

Modularity

The benefits from using a modular approach to application programming include the following:

- Faster compile time

The smaller the piece of code we compile, the faster the compiler can process it. This benefit is particularly important during maintenance, because often only

a line or two needs to be changed. When we change two lines, we may have to recompile 2000 lines. That is hardly an efficient use of resources.

If we modularize the code and take advantage of the binding capabilities of ILE, we may need to recompile only 100 or 200 lines. Even with the binding step included, this process is considerably faster.

- Simplified maintenance

When updating a very large program, it is very difficult to understand exactly what is going on. This is particularly true if the original programmer wrote in a different style from your own. A smaller piece of code tends to represent a single function, and it is far easier to grasp its inner workings. Therefore, the logical flow becomes more obvious, and when you make changes, you are far less likely to introduce unwanted side effects.

- Simplified testing

Smaller compilation units encourage you to test functions in isolation. This isolation helps to ensure that test coverage is complete; that is, that all possible inputs and logic paths are tested.

- Better use of programming resources

Modularity lends itself to greater division of labor. When you write large programs, it is difficult (if not impossible) to subdivide the work. Coding all parts of a program may stretch the talents of a junior programmer or waste the skills of a senior programmer.

- Easier migrating of code from other platforms

Programs written on other platforms, such as UNIX**, are often modular. Those modules can be migrated to the AS/400 system and incorporated into an ILE program.

Reusable Components

ILE allows you to select packages of routines that can be blended into your own programs. Routines written in any ILE language can be used by all AS/400 ILE compiler users. The fact that programmers can write in the language of their choice ensures you the widest possible selection of routines.

The same mechanisms that IBM and other vendors use to deliver these packages to you are available for you to use in your own applications. Your installation can develop its own set of standard routines, and do so in any language it chooses.

Not only can you use off-the-shelf routines in your own applications. You can also develop routines in the ILE language of your choice and market them to users of any ILE language.

Common Run-Time Services

A selection of off-the-shelf components (**bindable APIs**) is supplied as part of ILE, ready to be incorporated into your applications. These APIs provide services such as:

- Date and time manipulation
- Message handling
- Math routines
- Greater control over screen handling

Dynamic storage allocation

Over time, additional routines will be added to this set and others will be available from third-party vendors.

For further details of the APIs supplied with ILE, see the *System API Reference*.

Coexistence with Existing Applications

ILE programs can coexist with existing OPM programs. ILE programs can call OPM programs and other ILE programs. Similarly, OPM programs can call ILE programs and other OPM programs. Therefore, with careful planning, it is possible to make a gradual transition to ILE.

Source Debugger

The source debugger allows you to debug ILE programs and service programs. For information about the source debugger, see Chapter 9, “Debugging Considerations” on page 9-1.

Better Control over Resources

Before the introduction of ILE, resources (for example, open files) used by a program could be scoped to (that is, owned by) only:

- The program that allocated the resources
- The job

In many cases, this restriction forces the application designer to make tradeoffs.

ILE offers a third alternative. A portion of the job can own the resource. This alternative is achieved through the use of an ILE construct, the **activation group**. Under ILE, a resource can be scoped to any of the following:

- A program
- An activation group
- The job

Shared Open Data Path—Scenario

Shared open data paths (ODPs) are an example of resources you can better control with ILE’s new level of scoping.

To improve the performance of an application on the AS/400, a programmer decided to use a shared ODP for the customer master file. That file is used by both the Order Entry and the Billing applications.

Because a shared ODP is scoped to the job, it is quite possible for one of the applications to inadvertently cause problems for the other. In fact, avoiding such problems requires careful coordination among the developers of the applications. If the applications were purchased from different suppliers, avoiding problems may not even be possible.

What kind of problems can arise? Consider the following scenario:

1. The customer master file is keyed on account number and contains records for account numbers A1, A2, B1, C1, C2, D1, D2, and so on.

2. An operator is reviewing the master file records, updating each as required, before requesting the next record. The record currently displayed is for account B1.
3. The telephone rings. Customer D1 wants to place an order.
4. The operator presses the Go to Order Entry function key, processes the order for customer D1, and returns to the master file display.
5. The program still correctly displays the record for B1, but when the operator requests the next record, which record is displayed?

If you said D2, you are correct. When the Order Entry application read record D1, the current file position changed because the shared ODP was scoped to the job. Therefore, the request for the next record means the next record after D1.

Under ILE, this problem could be prevented by running the master file maintenance in an activation group dedicated to Billing. Likewise, the Order Entry application would run in its own activation group. Each application would still gain the benefits of a shared ODP, but each would have its own shared ODP, owned by the relevant activation group. This level of scoping prevents the kind of interference described in this example.

Scoping resources to an activation group allows programmers the freedom to develop an application that runs independently from any other applications running in the job. It also reduces the coordination effort required and enhances the ability to write drop-in extensions to existing application packages.

Commitment Control—Scenario

The ability to scope a shared open data path (ODP) to the application is useful in the area of commitment control.

Assume that you want to use a file under commitment control but that you also need it to use a shared ODP. Without ILE, if one program opens the file under commitment control, all programs in the job have to do so. This is true even if the commitment capability is needed for only one or two programs.

One potential problem with this situation is that, if any program in the job issues a commit operation, all updates are committed. The updates are committed even if logically they are not part of the application in question.

These problems can be avoided by running each part of the application that requires commitment control in a separate activation group.

Better Control over Language Interactions

Without ILE, the way a program runs on the AS/400 depends on a combination of the following:

- The language standard (for example, the ANSI standards for COBOL and C)
- The developer of the compiler

This combination can cause problems when you mix languages.

Mixed Languages—Scenario

Without activation groups, which are introduced by ILE, interactions among OPM languages are difficult to predict. ILE activation groups can solve that difficulty.

For example, consider the problems caused by mixing COBOL with other languages. The COBOL language standard includes a concept known as a **run unit**. A run unit groups programs together so that under certain circumstances they behave as a single entity. This can be a very useful feature.

Assume that three ILE COBOL/400 programs (PRGA, PRGB, and PRGC) form a small application in which PRGA calls PRGB, which in turn calls PRGC (see Figure 1-1). Under the rules of ILE COBOL/400, these three programs are in the same run unit. As a result, if any of them ends, all three programs should be ended and control should return to the caller of PRGA.

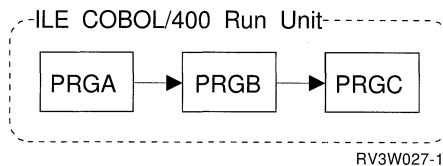

Figure 1-1. Three ILE COBOL/400 Programs in a Run Unit

Suppose that we now introduce an RPG program (RPG1) into the application and that RPG1 is also called by the COBOL program PRGB (see Figure 1-2). An RPG program expects that its variables, files, and other resources remain intact until the program returns with the last-record (LR) indicator on.

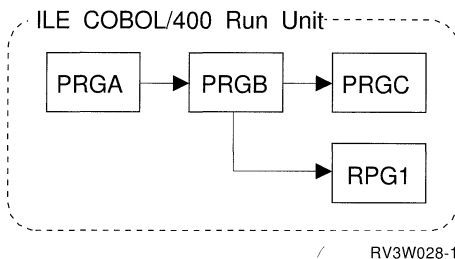

Figure 1-2. Three ILE COBOL/400 Programs and One ILE RPG/400 Program in a Run Unit

However, the fact that program RPG1 is written in RPG does not guarantee that all RPG semantics apply when RPG1 is run as part of the COBOL run unit. If the run unit ends, RPG1 disappears regardless of its LR indicator setting. In many cases, this situation may be exactly what you want. However, if RPG1 is a utility program, perhaps controlling the issue of invoice numbers, this situation is unacceptable.

We can prevent this situation by running the RPG program in a separate activation group from the COBOL run unit (see Figure 1-3 on page 1-6). An ILE COBOL/400 run unit itself is an activation group.

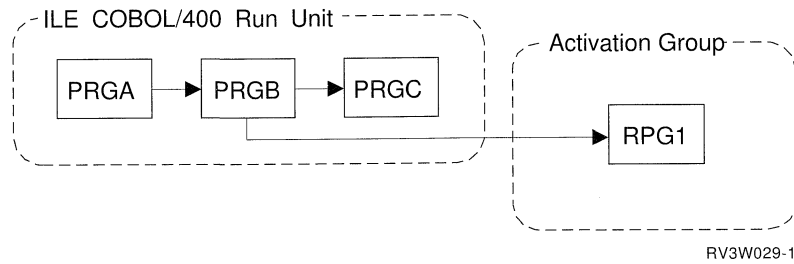

Figure 1-3. ILE RPG/400 Program in a Separate Activation Group

For information about the differences between an OPM run unit and an ILE run unit, see the *ILE COBOL/400 Programmer's Guide*.

Better Code Optimization

The ILE translator does many more types of optimization than the original program model (OPM) translator does. Although each compiler does some optimization, the majority of the optimization on the AS/400 is done by the translator.

An ILE-enabled compiler does not directly produce a module. First it produces an intermediate form of the module, and then it calls the ILE translator to translate the intermediate code into instructions that can be run.

Better Environment for C

C has become the language of choice for tool builders. Because of this, a better C language means that more and more of the latest application development tools are migrated to the AS/400. For you, this means a greater choice of:

- CASE tools
- Fourth-generation languages (4GLs)
- Additional programming languages
- Editors
- Debuggers

Foundation for the Future

The benefits and functions that ILE provides will be even more important in the future. Future ILE compilers will offer significant enhancements. As we move into object-oriented programming languages and visual programming tools, the need for ILE becomes even more apparent.

Increasingly, programming methods rely on a highly modularized approach. Applications are built by combining thousands of small reusable components to form the completed application. If these components cannot transfer control among themselves quickly, the resulting application cannot work.

What Is the History of ILE?

ILE is a stage in the evolution of OS/400* program models. Each stage evolved to meet the changing needs of application programmers.

The programming environment provided when the AS/400 system was first introduced is called the original program model (OPM). In Version 1 Release 2, the Extended Program Model (EPM) was introduced.

Original Program Model Description

Application developers on the AS/400 enter source code into a source file and compile that source. If the compilation is a success, a program object is created. The set of functions, processes, and rules provided by the OS/400 to create and run a program is known as the **original program model (OPM)**.

As an OPM compiler generates the program object, it generates additional code. The additional code initializes program variables and provides any necessary code for special processing that is needed by the particular language. The special processing could include processing any input parameters expected by this program. When a program is to start running, the additional compiler-generated code becomes the starting point (entry point) for the program.

A program is typically activated when the OS/400 encounters a call request. At run time, the call to another program is a **dynamic program call**. The resources needed for a dynamic program call can be significant. Application developers often design an application to consist of a few large programs that minimize the number of dynamic program calls.

Figure 1-4 illustrates the relationship between OPM and the operating system. As you can see, RPG, COBOL, CL, BASIC, and PL/I all operate in this model.

The broken line forming the OPM boundary indicates that OPM is an integral part of OS/400. This integration means that many functions normally provided by the compiler writer are built into the operating system. The resulting standardization of calling conventions allows programs written in one language to freely call those written in another. For example, an application written in RPG typically includes a number of CL programs to issue file overrides, to perform string manipulations, or to send messages.

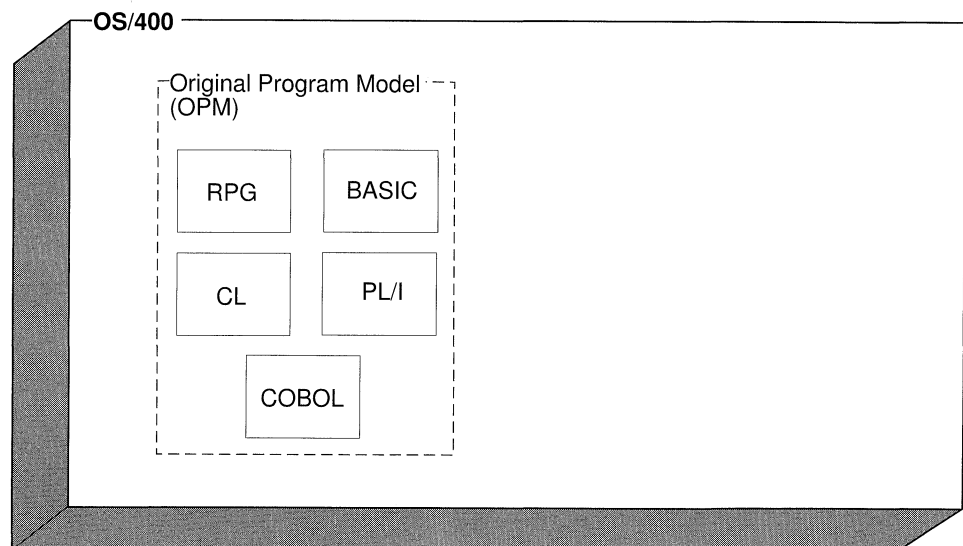

RV2W976-2

Figure 1-4. Relationship of OPM to OS/400

Principal Characteristics of OPM

The following list identifies the principal characteristics of OPM:

- Good for traditional RPG and COBOL programs

OPM is ideal for supporting traditional RPG and COBOL programs, that is, relatively large, multifunction programs.

- Dynamic binding

When program A wants to call program B, it just does so. This dynamic program call is a simple and powerful capability. At run time, the operating system locates program B and ensures that the user has the right to use it.

As previously noted, however, a dynamic program call requires considerable resources. There also can be other drawbacks. When a program is called, OS/400 checks to see if the program is activated. If it is, that copy of the program is given control. This capability can be very useful, but it is not always what you want. Sometimes you would like a new copy of the program's variables, reset to their initial states, while keeping the original copy in its current state.

In RPG or COBOL, achieving this situation can be a laborious process. It involves additional coding or sometimes duplicating the program object itself.

- Limited data sharing

OPM provides limited support for data sharing. Typically, to share data between programs in an application, you pass the data as parameters on a CALL statement. This method is normally quite effective, except in those cases where the data is not processed by the next program in sequence.

For example, suppose that program A originates a piece of data that is to be processed by program D. If the normal sequence of events is for A to call B, which calls C, which calls D, the parameter has to be passed from program to program, even though neither B nor C uses it.

Under OPM, system support for other types of data sharing was limited. Therefore, the RPG and COBOL compiler writers decided not to include such support. As a result, OPM programmers have to use alternative techniques. These techniques include storing the data in a local data area (LDA), in a database, or in a user space.

Extended Program Model Description

OPM continues to serve a useful purpose. However, OPM does not provide direct support for procedures as defined in languages like C. A **procedure** is a set of self-contained high-level language (HLL) statements that performs a particular task and then returns to the caller. Individual languages vary in the way that a procedure is defined. In C, a procedure is called a function.

To allow languages that define procedure calls between compilation units or that define procedures with local variables to run on an AS/400, OPM was enhanced. These enhancements are called the **Extended Program Model (EPM)**. As shown in Figure 1-5 on page 1-9, EPM was created to support languages like Pascal and FORTRAN. Along with the base OPM support, EPM provides the ability to call procedures located in other programs. Because EPM uses the functions of OPM, some procedure calls in EPM turn into dynamic calls to the program containing the procedure. Conceptually, the entry point of the called EPM program provides the following functions:

Initializes the program variables
Calls the identified procedure

The system support to help resolve the procedure calls to the appropriate programs is provided by the Set Program Information (SETPGMINF) command.

Although EPM is a different programming model from OPM, it is closely tied to OPM. EPM is built as an additional layer above the AS/400 high-level machine interface. Most of the functions associated with OPM also apply to EPM.

In the following chapters of this manual, the term OPM means both OPM and EPM. Functions that apply only to EPM are specifically qualified with the term EPM.

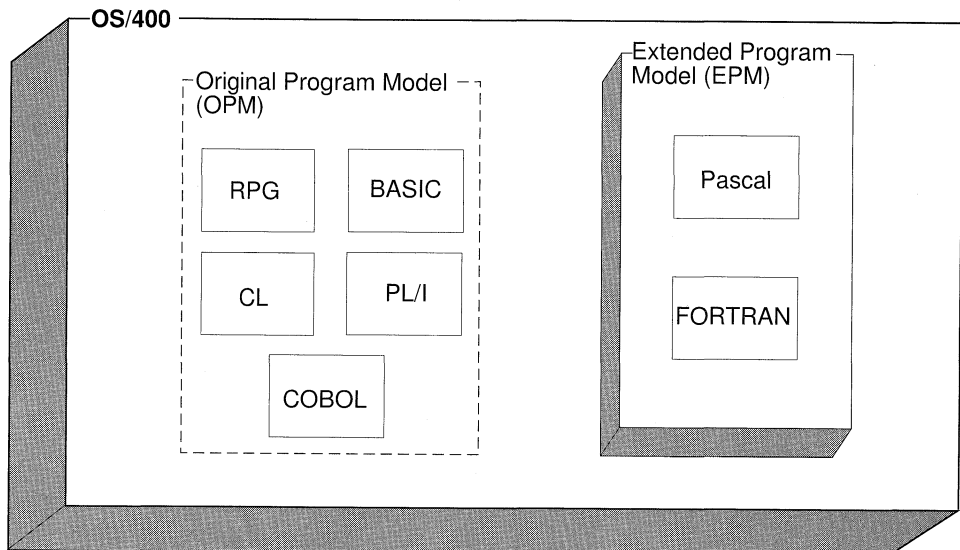

RV3W103-0

Figure 1-5. Relationship of OPM and EPM to OS/400

The shaded area around the EPM block indicates that, unlike OPM, EPM is not incorporated into OS/400. Rather, it is a layer on top of the operating system. It provides the additional support required for procedure-based languages.

Principal Characteristics of Procedure-Based Languages

Procedure-based languages have the following characteristics:

- Locally scoped variables

Locally scoped variables are known only within the procedure that defines them. The equivalent of locally scoped variables is the ability to define two variables with the same name that refer to two separate pieces of data. For example, the variable COUNT might have a length of 4 digits in subroutine CALCYR and a length of 6 digits in subroutine CALCDAY.

Locally scoped variables provide considerable benefit when you write subroutines that are intended to be copied into several different programs. Today, to avoid potential naming conflicts, many programmers use a scheme for naming variables based on the name of the subroutine.

- Automatic variables

Automatic variables are created whenever a procedure is entered. Automatic variables are destroyed when the procedure is exited.

- External variables

External data is one way of sharing data between programs. If program A declares a data item as external, program A is said to **export** that data item to other programs that want to share that data. Program D can then **import** the item without programs B and C being involved at all. For more information about imports and exports, see “Module Object” on page 2-2.

- Multiple entry points

COBOL and RPG programs have only a single entry point. In a COBOL program, it is the start of the PROCEDURE DIVISION. In an RPG program, it is the first-page (1P) output. This is the model that OPM supports.

Procedure-based languages, on the other hand, may have multiple entry points. For example, a C program may consist entirely of subroutines to be used by other programs. These procedures can be exported, along with relevant data if required, for other programs to import.

In ILE, programs of this type are known as **service programs**. They can include modules from any of the ILE languages. Service programs are similar in concept to dynamic link libraries (DLLs) in Windows** or OS/2*. Service programs are discussed in greater detail in “Service Program” on page 2-5.

- Frequent calls

Procedure-based languages are by nature very call intensive. Although EPM provides some functions to minimize the overhead of calls, procedure calls between separately compiled units still have a relatively high overhead. ILE improves this type of call significantly.

Integrated Language Environment Description

As Figure 1-6 shows, ILE is tightly integrated into OS/400, just as OPM is. It provides the same type of support for procedure-based languages that EPM does, but it does so far more thoroughly and consistently. Its design provides for the more traditional languages, such as RPG and COBOL, and for future language developments.

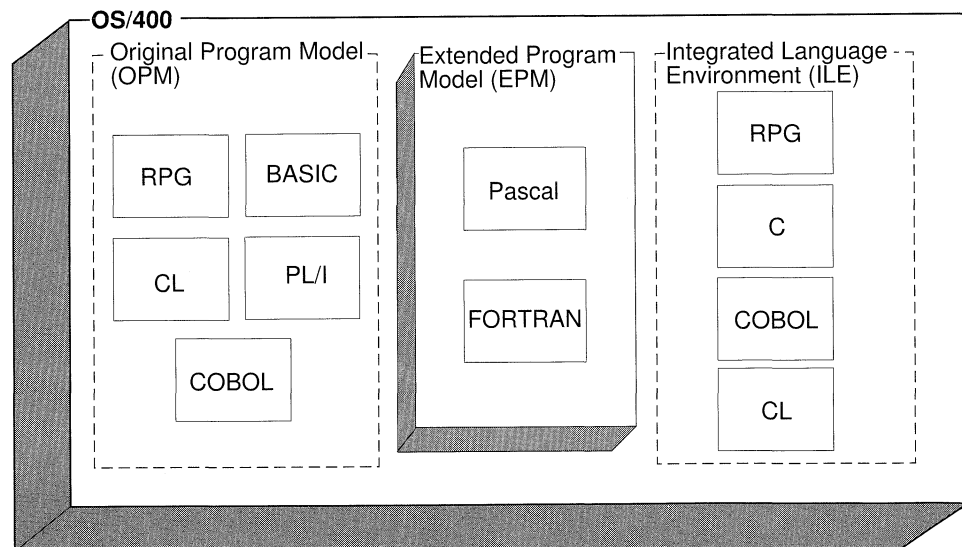

RV3W026-1

Figure 1-6. Relationship of OPM, EPM, and ILE to OS/400

Chapter 2. ILE Basic Concepts

Table 2-1 compares and contrasts the original program model (OPM) and the Integrated Language Environment (ILE) model. This chapter briefly explains the similarities and differences listed in the table.

Table 2-1. Similarities and Differences between OPM and ILE

OPM	ILE
Program	Program Service program
Compilation results in a runnable program	Compilation results in a nonrunnable module object
Compile, run	Compile, bind, run
Run units simulated for each language	Activation groups
Dynamic program call	Dynamic program call Static procedure call
Single-language focus	Mixed-language focus
Language-specific error handling	Common error handling Language-specific error handling
OPM debuggers	Source-level debugger OPM debuggers

Structure of an ILE Program

An ILE program contains one or more modules. A module, in turn, contains one or more procedures (see Figure 2-1).

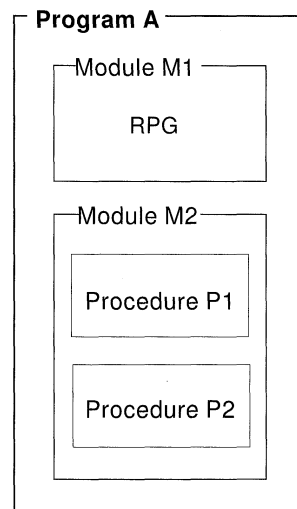

RV2W1003-2

Figure 2-1. Structure of an ILE Program

Procedure

A **procedure** is a set of self-contained high-level language statements that performs a particular task and then returns to the caller. For example, an ILE C/400 function is an ILE procedure.

Module Object

A **module object** is a *nonrunnable* object that is the output of an ILE compiler. A module object is represented to the system by the symbol *MODULE. A module object is the basic building block for creating runnable ILE objects. This is a significant difference between ILE and OPM. The output of an OPM compiler is a *runnable* program.

A module object can consist of one or more procedures and data item specifications. It is possible to directly access the procedures or data items in one module from another ILE object. See the ILE HLL programmer's guides for details on coding the procedures and data items that can be directly accessed by other ILE objects.

ILE RPG/400, ILE COBOL/400, and ILE C/400 all have the following common concepts:

- Exports

An **export** is the name of a procedure or data item, coded in a module object, that is available for use by other ILE objects. The export is identified by its name and its associated type, either procedure or data.

An export can also be called a **definition**.

- Imports

An **import** is the use of or reference to the name of a procedure or data item not defined in the current module object. The import is identified by its name and its associated type, either procedure or data.

An import can also be called a **reference**.

A module object is the basic building block of an ILE runnable object. Therefore, when a module object is created, the following may also be generated:

- Debug data

Debug data is the data necessary for debugging a running ILE object. This data is optional.

- Program entry procedure (PEP)

A **program entry procedure** is the compiler-generated code that is the entry point for an ILE program on a dynamic program call. It is similar to the code provided for the entry point in an OPM program.

- User entry procedure (UEP)

A **user entry procedure**, written by a programmer, is the target of the dynamic program call. It is the procedure that gets control from the PEP. The main() function of a C program becomes the UEP of that program in ILE.

Figure 2-2 on page 2-3 shows a conceptual view of a module object. In this example, module object M1 exports two procedures (Draw_Line and Draw_Arc) and a data item (rtn_code). Module object M1 imports a procedure called Draw_Plot. This particular module object has a PEP, a corresponding UEP (the procedure Draw_Arc), and debug data.

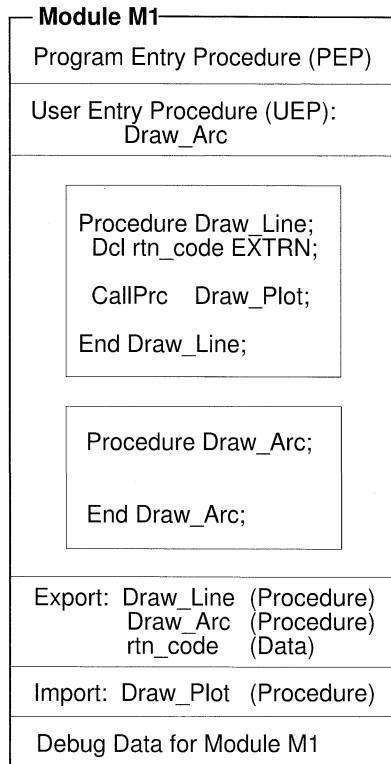

RV3W104-0

Figure 2-2. Conceptual View of a Module

Characteristics of a *MODULE object:

- A *MODULE object is the output from an ILE compiler.
- It is the basic building block for ILE runnable objects.
- It is not a runnable object.
- It may have a PEP defined.
- If a PEP is defined, a UEP is also defined.
- It can export procedure and data item names.
- It can import procedure and data item names.
- It can have debug data defined.

ILE Program

An ILE program shares the following characteristics with an OPM program:

- The program gets control through a dynamic program call.
- There is only one entry point to the program.
- The program is identified to the system by the symbol *PGM.

An ILE program has the following characteristics that an OPM program does not have:

- An ILE program is created from one or more copied module objects.
- One or more of the copied modules can contain a PEP.
- You have control over which module's PEP is used as the PEP for the ILE program object.

When the Create Program (CRTPGM) command is specified, the ENTMOD parameter allows you to select which module containing a PEP is the program's entry point.

A PEP that is associated with a module that is not selected as the entry point for the program is ignored. All other procedures and data items of the module are used as specified. Only the PEP is ignored.

When a dynamic program call is made to an ILE program, the module's PEP that was selected at program-creation time is given control. The PEP calls the associated UEP.

When an ILE program object is created, only those procedures associated with the copied modules containing debug data can be debugged by the ILE debugger. The debug data does not affect the performance of a running ILE program.

Figure 2-3 shows a conceptual view of an ILE program object. When the program PGMEXAMP is called, the PEP of the program, which was defined in the copied module object M3, is given control. The copied module M2 also has a PEP defined, but it is ignored and never used by the program.

In this program example, only two modules, M1 and M3, have the necessary data for the new ILE debugger. Procedures from modules M2 and M4 cannot be debugged by using the new ILE debugger.

The imported procedures print and SIN are resolved to exported procedures from service programs PRINTS and MATHFUNC, respectively.

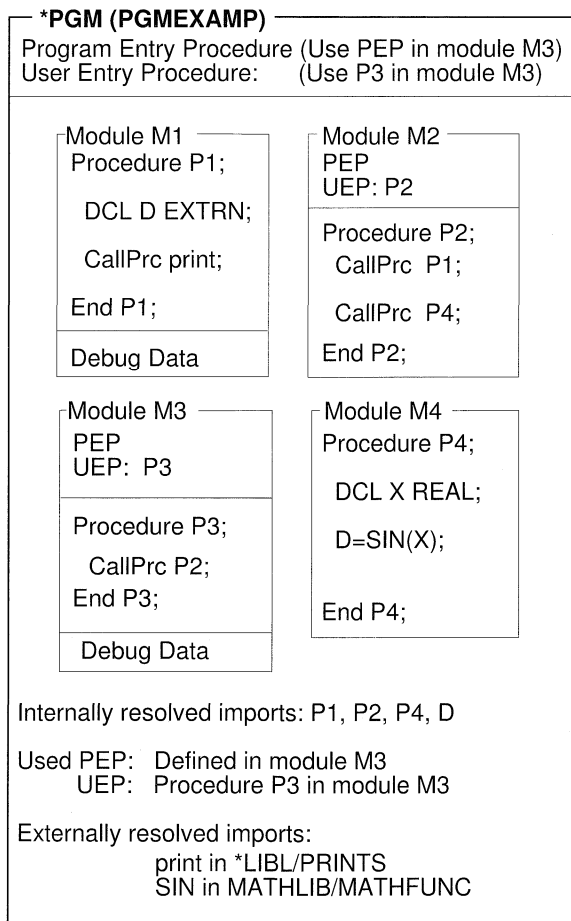

RV2W980-5

Characteristics of an ILE *PGM object:

- One or more modules from any ILE language are copied to make the *PGM object.
- The person who creates the program has control over which module's PEP becomes the only PEP for the program.
- On a dynamic program call, the module's PEP that was selected as the PEP for the program gets control to run.
- The UEP associated with the selected PEP is the user's entry point for the program.
- Procedures and data item names cannot be exported from the program.
- Procedures or data item names can be imported from modules and service programs but not from program objects. For information on service programs, see "Service Program" on page 2-5.
- Modules can have debug data.
- A program is a runnable object.

Figure 2-3. Conceptual View of an ILE Program

Service Program

A **service program** is a collection of runnable procedures and available data items easily and directly accessible by other ILE programs or service programs. In many respects, a service program is similar to a subroutine library or procedure library.

Service programs provide common services that other ILE objects may need; hence the name service program. An example of a set of service programs provided by OS/400 are the run-time procedures for a language. These run-time procedures often include such items as mathematical procedures and common input/output procedures.

The **public interface** of a service program consists of the names of the exported procedures and data items accessible by other ILE objects. Only those items that are exported from the module objects making up a service program are eligible to be exported from a service program.

The programmer can specify which procedures or data items can be known to other ILE objects. Therefore, a service program can have hidden or private procedures and data that are not available to any other ILE object.

It is possible to update a service program without having to re-create the other ILE programs or service programs that use the updated service program. The programmer making the changes to the service program controls whether the change is compatible with the existing support.

The way that ILE provides for you to control compatible changes is by using the **binder language**. The binder language allows you to define the list of procedure names and data item names that can be exported. A **signature** is generated from the names of procedures and data items and from the order in which they are specified in the binder language. To make compatible changes to a service program, new procedure or data item names should be added to the end of the export list. For more information on signatures, the binder language, and protecting your customers' investment in your service programs, see "Binder Language" on page 4-10.

Figure 2-4 on page 2-6 shows a conceptual view of a service program. Notice that the modules that make up that service program are the same set of modules that make up ILE program object PGMEXAMP in Figure 2-3 on page 2-4. The previous signature, Sigyy, for service program SPGMEXAMP contains the names of procedures P3 and P4. After an upward-compatible change is made to the service program, the current signature, Sigxx, contains not only the names of procedures P3 and P4; it also contains the name of data item D. Other ILE programs or service programs that use procedures P3 or P4 do not have to be re-created.

Although the modules in a service program may have PEPs, these PEPs are ignored. The service program itself does not have a PEP. Therefore, unlike a program object, a service program cannot be called dynamically.

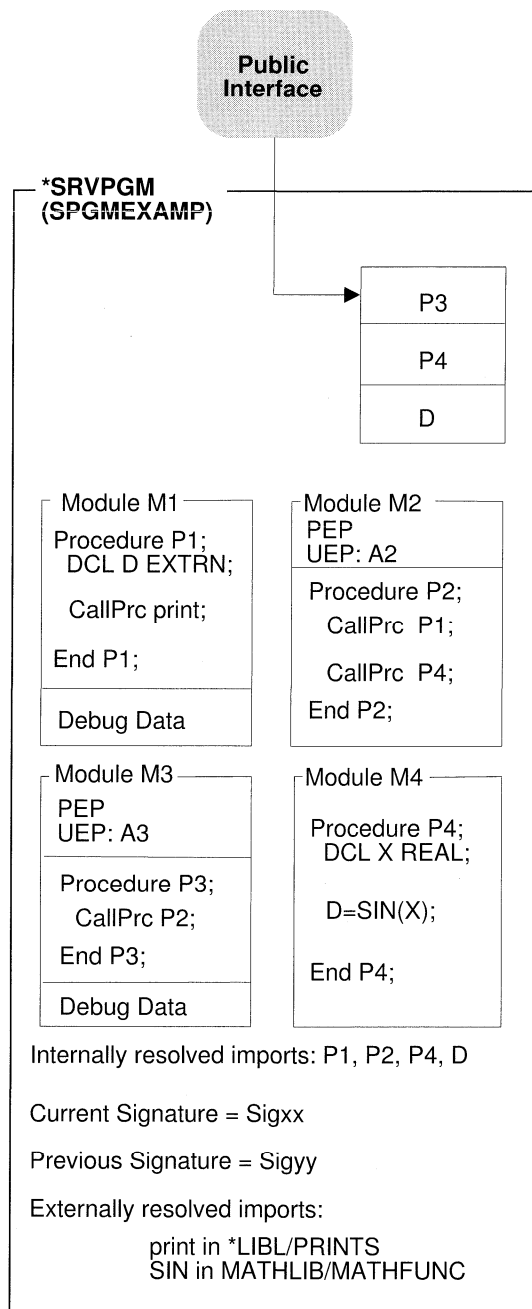

RV2W981-8

Figure 2-4. Conceptual View of an ILE Service Program

Characteristics of an ILE *SRVPGM object:

- One or more modules from any ILE language are copied to make the *SRVPGM object.
- No PEP is associated with the service program. Because there is no PEP, a dynamic program call to a service program is not valid. A module's PEP is ignored.
- Other ILE programs or service programs can use the exports of this service program identified by the public interface.
- Signatures are generated from the procedure and data item names that are exported from the service program.
- Service programs can be replaced without affecting the ILE programs or service programs that use them, as long as previous signatures are still supported.
- Modules can have debug data.
- A service program is a collection of runnable procedures and data items.
- Weak data can be exported only to an activation group. It cannot be made part of the public interface that is exported from the service program. For information about weak data, see Export in "Binder Information Listing for Example Service Program" on page A-7.

Binding Directory

A **binding directory** contains the names of modules and service programs that you may need when creating an ILE program or service program. Modules or service programs listed in a binding directory are used only if they provide an export that can satisfy any currently unresolved import requests. A binding directory is a system object that is identified to the system by the symbol *BNDDIR.

Binding directories are optional. The reasons for using binding directories are convenience and program size.

- They offer a convenient method of packaging the modules or service programs that you may need when creating your own ILE program or service program. For example, one binding directory may contain all the modules and service programs that provide math functions. If you want to use some of those functions, you specify only the one binding directory, not each module or service program you use.
- Binding directories can reduce program size because you do not specify modules or service programs that do not get used.

Very few restrictions are placed on the entries in a binding directory. The name of a module or service program can be added to a binding directory even if that object does not yet exist.

For a list of CL commands used with binding directories, see Appendix C, "CL Commands Used with ILE Objects" on page C-1.

Figure 2-5 shows a conceptual view of a binding directory.

<u>Object Name</u>	<u>Object Type</u>	<u>Object Library</u>
QALLOC	*SRVPGM	*LIBL
QMATH	*SRVPGM	QSYS
QFREE	*MODULE	*LIBL
QHFREE	*SRVPGM	ABC
▪	▪	▪
▪	▪	▪
▪	▪	▪

RV2W982-0

Figure 2-5. Conceptual View of a Binding Directory

Characteristics of a *BNDDIR object:

- Convenient method of grouping the names of service programs and modules that may be needed to create an ILE program or service program.
- Because binding directory entries are just names, the objects listed do not have to exist yet on the system.
- The only valid library names are *LIBL or a specific library.
- The objects in the list are optional. The named objects are used only if any unresolved imports exist and if the named object provides an export to satisfy the unresolved import request.

Binder Functions

The function of the binder is similar to, but somewhat different from, the function provided by a linkage editor. The **binder** processes import requests for procedure names and data item names from specified modules. The binder then tries to find matching exports in the specified modules, service programs, and binding directories.

In creating an ILE program or service program, the binder performs the following types of binding:

- Bind by copy

To create the ILE program or service program, the following are copied:

The modules specified on the module parameter

Any modules selected from the binding directory that provide an export for an unresolved import

Physical addresses of the needed procedures and data items used within the copied modules are established when the ILE program or service program is created.

For example, in Figure 2-4 on page 2-6, procedure P3 in module M3 calls procedure P2 in module M2. The physical address of procedure P2 in module M2 is made known to procedure M3 so that address can be directly accessed.

- Bind by reference

Symbolic links to the service programs that provide exports for unresolved import requests are saved in the created program or service program. The symbolic links refer to the service programs providing the exports. The links are converted to physical addresses when the program object to which the service program is bound is activated.

Figure 2-4 on page 2-6 shows an example of a symbolic link to SIN in service program *MATHLIB/MATHFUNC. The symbolic link to SIN is converted to a physical address when the program object to which service program SPGMEXAMP is bound is activated.

At run time, with physical links established to the procedures and data items being used, there is little performance difference between the following:

- Accessing a local procedure or data item
- Accessing a procedure or data item in a different module or service program bound to the same program

Figure 2-6 on page 2-9 and Figure 2-7 on page 2-9 show conceptual views of how the ILE program PGMEXAMP and service program SPGMEXAMP were created. The binder uses modules M1, M2, M3, and M4 and service programs PRINTS and MATHFUNC to create ILE program PGMEXAMP and service program SPGMEXAMP.

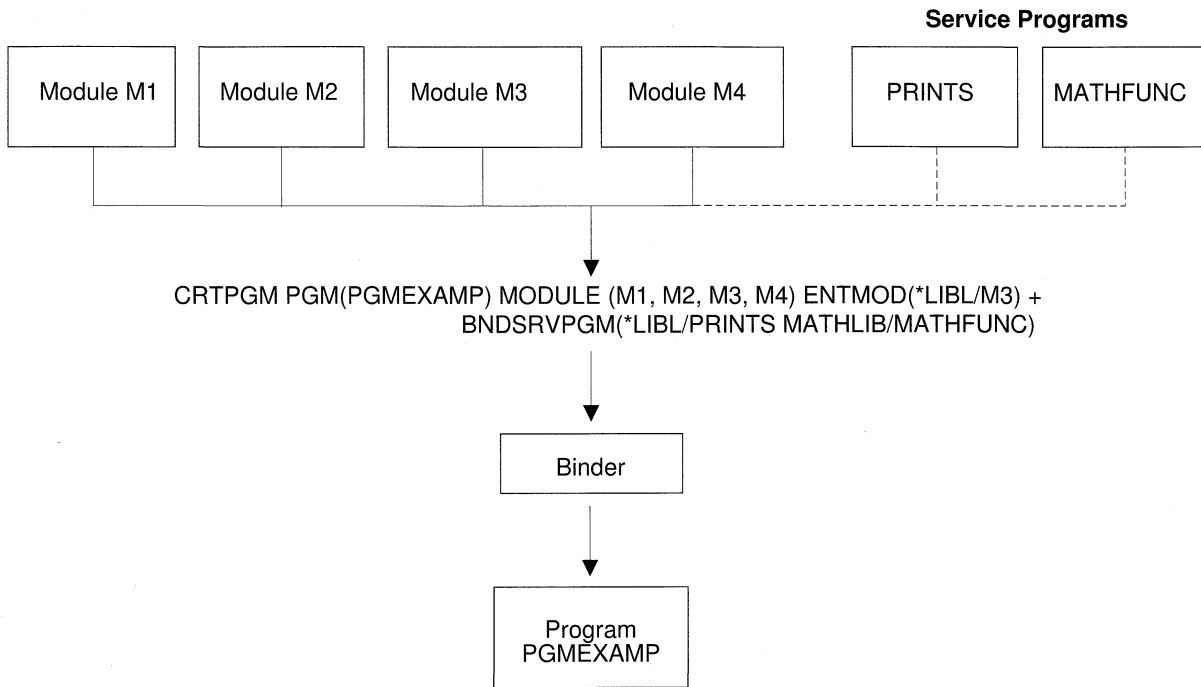

RV2W983-3

Figure 2-6. Creation of an ILE Program. The broken line indicates that the service programs are bound by reference instead of being bound by copy.

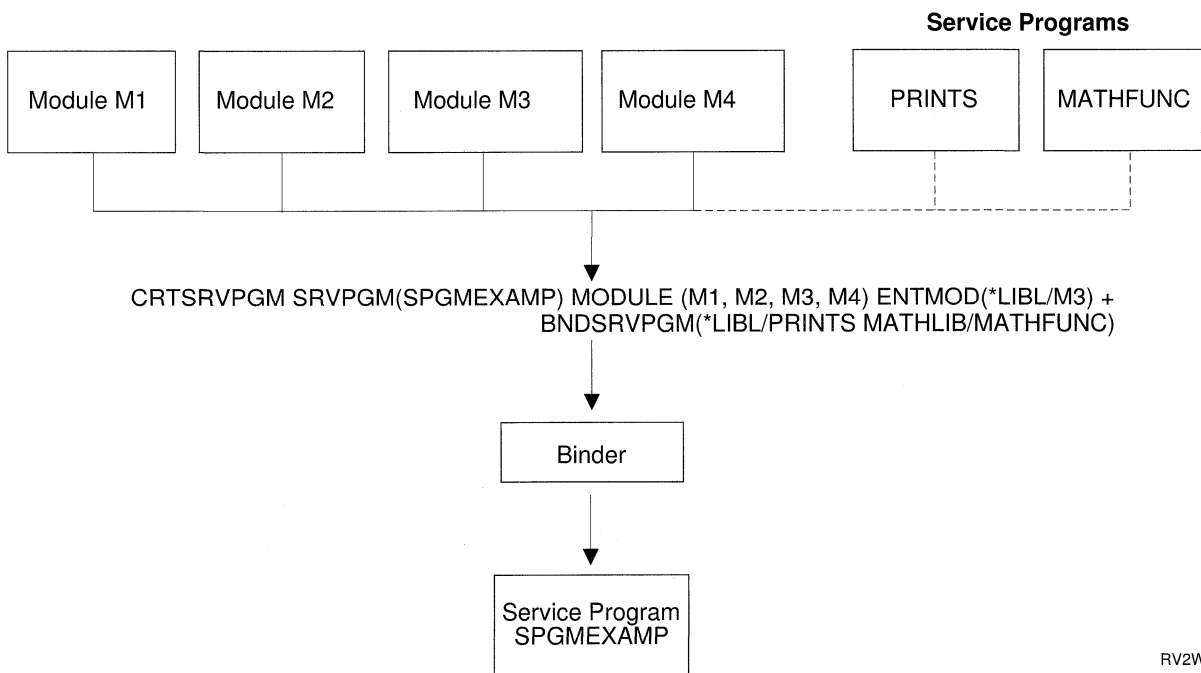

RV2W984-3

Figure 2-7. Creation of a Service Program. The broken line indicates that the service programs are bound by reference instead of being bound by copy.

For additional information on creating an ILE program or service program, see Chapter 4, "Program Creation Concepts" on page 4-1.

Calls to Programs and Procedures

In ILE you can call either a program or a procedure. ILE requires that the caller identify whether the target of the call statement is a program or a procedure. ILE languages communicate this requirement by having separate call statements for programs and for procedures. Therefore, when you write your ILE program, you must know whether you are calling a program or a procedure.

Each ILE language has unique syntax that allows you to distinguish between a dynamic program call and a static procedure call. The standard call statement in each ILE language defaults to either a dynamic program call or a static procedure call. For RPG and COBOL the default is a dynamic program call, and for C the default is a static procedure call. Thus, the standard language call performs the same type of function in either OPM or ILE. This convention makes migrating from an OPM language to an ILE language relatively easy.

The binder can handle a procedure name that is up to 256 characters long. To determine how long your procedure names can be, see your ILE HLL programmer's guide.

Dynamic Program Calls

A **dynamic program call** transfers control to either an ILE program object or an OPM program object. Dynamic program calls include the following:

- An OPM program can call another OPM program or an ILE program, but it cannot call a service program.
- An ILE program can call an OPM program or another ILE program, but it cannot call a service program.
- A service program can call an OPM program or an ILE program, but it cannot call another service program.

Static Procedure Calls

A **static procedure call** transfers control to an ILE procedure. Static procedure calls can be coded only in ILE languages. A static procedure call can be used to call any of the following:

- A procedure within the same module
- A procedure in a separate module within the same ILE program or service program
- A procedure in a separate ILE service program

Figure 2-8 shows examples of static procedure calls. The figure shows that:

- A procedure in an ILE program can call an exported procedure in the same program or in a service program. Procedure P1 in program A calls procedure P2 in another copied module. Procedure P3 in program C calls procedure P4 in service program D.
- A procedure in a service program can call an exported procedure in the same service program or in another service program. Procedure P6 in service program B calls procedure P7 in another copied module. Procedure P5 in service program E calls procedure P4 in service program F.

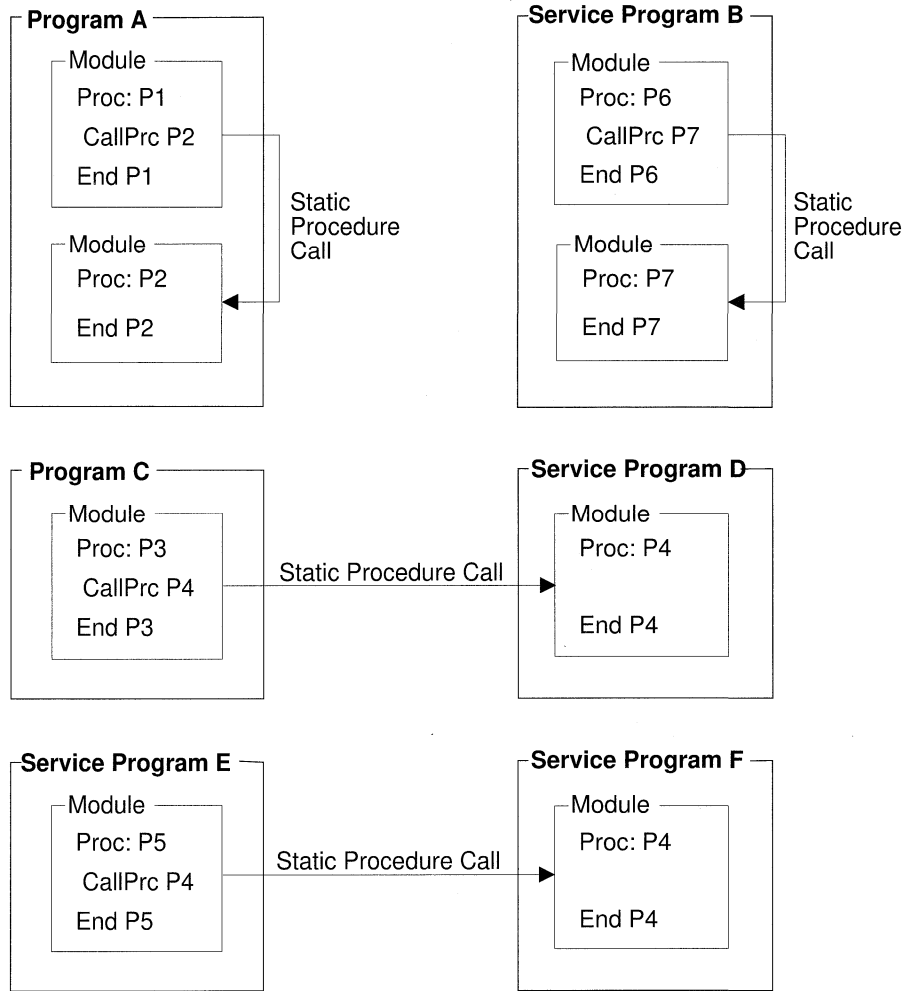

RV2W993-2

Figure 2-8. Static Procedure Calls

Activation

After successfully creating an ILE program, you will want to run your code. The process of getting a program or service program ready to run is called **activation**. You do not have to issue a command to activate a program. Activation is done by the system when a program is called. Because service programs are not called, they are activated during the call to a program that directly or indirectly requires their services.

Activation performs the following functions:

- Uniquely allocates the static data needed by the program or service program
- Changes the symbolic links to service programs providing the exports into links to physical addresses

No matter how many jobs are running a program or service program, only one copy of that object's instructions reside in storage. The only way to keep the program running correctly is for each job to have its own copy of the program's variables. Activation helps ensure that your job's version of the running program or service program does not intrude on another job using the same object. A program can be activated in more than one activation group, even within the same job, but activation is local to a particular activation group.

If either of the following is true:

- Activation cannot find the needed service program
- The service program no longer supports the procedures or data items represented by the signature

an error occurs and you cannot run your application.

For more details on program activation, refer to "Program Activation Creation" on page 3-2.

When activation allocates the storage necessary for the static variables used by a program, the space is allocated from an activation group. At the time the program or service program is created, you can specify the activation group that should be used at run time.

For more information on activation groups, refer to "Activation Group" on page 3-3.

Error Handling

Figure 2-9 shows the complete error-handling structure for both OPM and ILE programs. This figure is used throughout this manual to describe advanced error-handling capabilities. This topic gives a brief overview of the standard language error-handling capabilities. For additional information on error handling, refer to “Error Handling” on page 3-12.

The figure shows a fundamental layer called exception message architecture. An exception message may be generated by the system whenever an OPM program or an ILE program encounters an error. Exception messages are also used to communicate status information that may not be considered a program error. For example, a condition that a database record is not found is communicated by sending a status exception message.

Each high-level language defines language-specific error-handling capabilities. Although these capabilities vary by language, in general it is possible for each HLL user to declare the intent to handle specific error situations. The declaration of this intent includes identification of an error-handling routine. When an exception occurs, the system locates the error-handling routine and passes control to user-written instructions. You can take various actions, including ending the program or recovering from the error and continuing.

Figure 2-9 shows that ILE uses the same exception-message architecture that is used by OPM programs. Exception messages generated by the system initiate language-specific error handling within an ILE program just as they do within an OPM program. The lowest layer in the figure includes the capability for you to send and receive exception messages. This can be done with message handler APIs or commands. Exception messages can be sent and received between ILE and OPM programs.

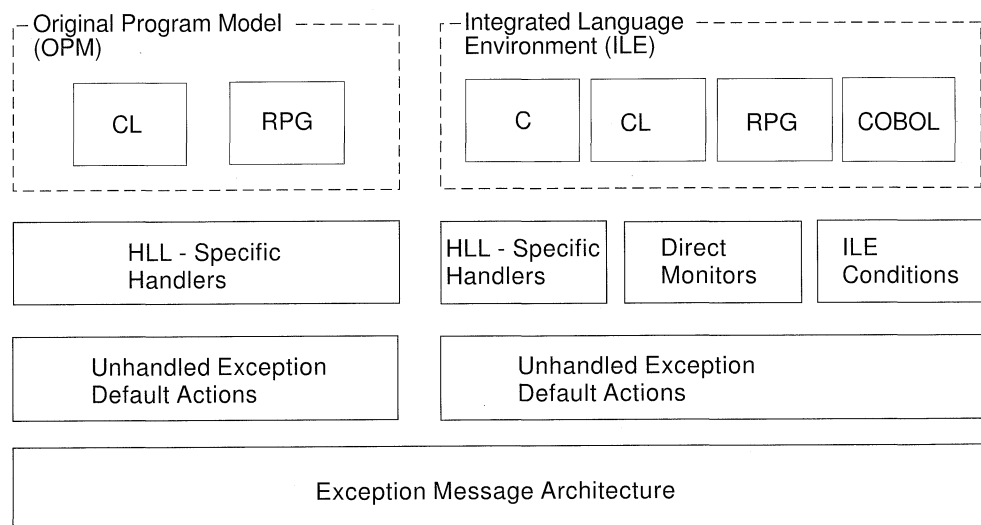

RV3W101-0

Figure 2-9. Error Handling for OPM and ILE

Language-specific error handling works similarly for ILE programs as for OPM programs, but there are basic differences:

- When the system sends an exception message to an ILE program, the procedure and module name are used to qualify the exception message. If you send

an exception message, these same qualifications can be specified. When an exception message appears in the job log for an ILE program, the system normally supplies the program name, module name, and procedure name.

- Extensive optimization for ILE programs can result in multiple HLL statement numbers associated with the same generated instructions. As the result of optimization, exception messages that appear in the job log may contain multiple HLL statement numbers.

Additional error-handling capabilities are described in “Error Handling” on page 3-12.

Optimizing Translator

On the AS/400, **optimization** means maximizing the run-time performance of the object. All ILE languages have access to the optimization techniques provided by the ILE optimizing translator. Generally, the higher the optimizing request, the longer it takes to create the object. At run time, highly optimized programs or service programs should run faster than corresponding programs or service programs created with a lower level of optimization.

Although optimization can be specified for a module, program object, and service program, the optimization techniques apply to individual modules. The levels of optimization are *NONE (minimal optimization), *BASIC (some optimization), and *FULL (maximum optimization).

For performance reasons, you probably want a high level of optimization when you use a module in production. Test your code at the optimization level at which you expect to use it. Verify that everything works as expected, then make the code available to your users.

Because optimization at level *FULL can significantly affect your program instructions, you may need to be aware of certain addressing exceptions and debugging limitations. Refer to Chapter 9, “Debugging Considerations” on page 9-1 for debug considerations. Refer to Appendix B, “Optimization Errors” on page B-1 for addressing error considerations.

Debugger

ILE provides a debugger that allows source-level debugging. The debugger can work with a listing file and allow you to set breakpoints, display variables, and step into or over an instruction. You can do these without ever having to enter a command from the command line. A command line is also available while working with the debugger.

The source-level debugger uses system-provided APIs to allow you to debug your program or service program. These APIs are available to everyone and allow you to write your own debugger.

The debuggers for OPM programs continue to exist on the AS/400 system but can be used to debug only OPM programs.

When you debug an optimized module, some confusion may result. When you use the ILE debugger to view or change a variable being used by a running program or procedure, the following happens. The debugger retrieves or updates the data in the storage location for this variable. At *BASIC or *FULL optimization, the current value of a data variable may be in a hardware register, where the debugger cannot access it. (Whether a data variable is in a hardware register depends on several factors. Those factors include how the variable is used, its size, and where in the code you stopped to examine or change the data variable.) Thus, the value displayed for a variable may not be the current value. For this reason, you should use an optimization level of *NONE during development. Then, for best performance, you should change the optimization level to *FULL during production.

For more information on the ILE debugger, see Chapter 9, "Debugging Considerations" on page 9-1.

Chapter 3. ILE Advanced Concepts

This chapter describes advanced concepts for the ILE model. Before reading this chapter, you should be familiar with the concepts described in Chapter 2, "ILE Basic Concepts" on page 2-1.

Program Activation

Activation is the process used to prepare a program to run. Both ILE programs and ILE service programs must be activated by the system before they can be run.

Program activation includes two major steps:

1. Allocate and initialize static storage for the program.
2. Complete the binding of programs to service programs.

This topic concentrates on step 1. Step 2 is explained in "Service Program Activation" on page 3-8.

Figure 3-1 on page 3-2 shows two ILE program objects stored in permanent disk storage. As with all OS/400 objects, these program objects may be shared by multiple concurrent users running in different OS/400 jobs. Only one copy of the program's code exists. When one of these ILE programs is called, however, variables declared within the program must be allocated and initialized for each program activation. These variables are called **static variables**.

As shown in Figure 3-1, each program activation supports at least one unique copy of these variables. Multiple copies of variables with the same name can exist within one program activation. This occurs if your HLL allows you to declare static variables that are scoped to individual procedures.

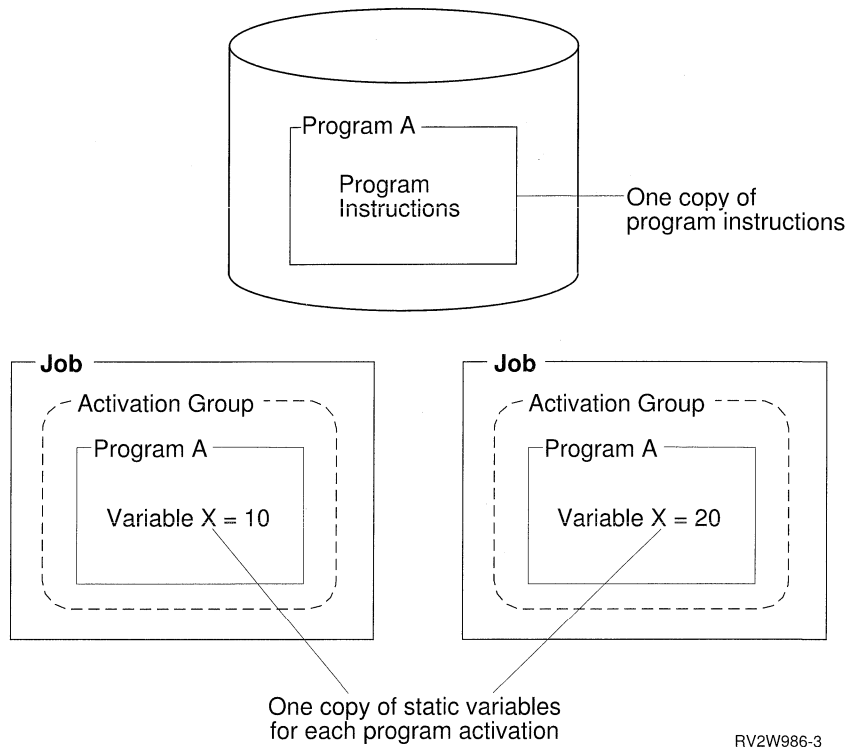

RV2W986-3

Figure 3-1. One Copy of Static Variables for Each Program Activation

Program Activation Creation

An ILE program activation is created as part of an HLL dynamic program call. ILE manages the process of program activation by keeping track of program activations within an activation group. Refer to “Activation Group” on page 3-3 for a definition of an activation group. Only one activation for a particular program object is in an activation group. Programs of the same name residing in different AS/400 libraries are considered different program objects when applying this rule.

When you use a dynamic program call statement in your HLL program, ILE uses the activation group that was specified when the program was created. This attribute is specified by using the activation group (ACTGRP) parameter on either the Create Program (CRTPGM) command or the Create Service Program (CRTSRVPGM) command. If a program activation already exists within the activation group indicated with this parameter, it is used. If the program has never been activated within this activation group, it is activated first and then run.

Once a program is activated, it remains activated until the activation group is deleted. As a result of this rule, it is possible to have active programs that are not on the call stack within the activation group. Figure 3-2 on page 3-3 shows an example of three active programs within an activation group, but only two of the three programs have procedures on the call stack. In this example, program A calls program B, causing program B to be activated. Program B then returns to program A. Program A then calls program C. The resulting call stack contains procedures for programs A and C but not for program B. For a discussion of the call stack, see “Call Stack” on page 6-1.

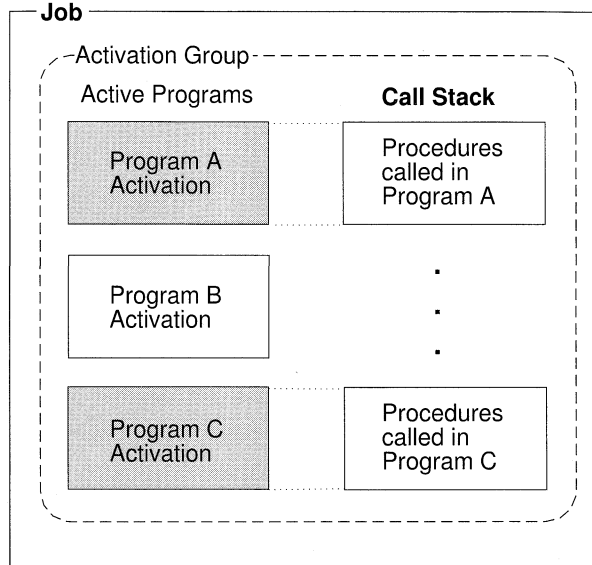

RV2W987-3

Figure 3-2. Program May Be Active But Not on the Call Stack

Activation Group

All ILE programs and service programs are activated within a substructure of a job called an **activation group**. This substructure contains the resources necessary to run the programs. These resources fall into the following general categories:

- Static and automatic program variables
- Dynamic storage
- Temporary data management resources
- Certain types of exception handlers and ending procedures

The static and automatic program variables and dynamic storage are assigned separate address spaces for each activation group. This provides some degree of program isolation and protection from accidental access.

The temporary data management resources include the following:

- Open files (open data path or ODP)
- Commitment definitions
- Local SQL cursors
- Remote SQL cursors
- Hierarchical file system (HFS)
- User interface manager
- Query management instances
- Open communications links
- Common Programming Interface (CPI) communications

The separation of these resources among activation groups supports a fundamental concept. That is, the concept that all programs activated within one activation group are developed as one cooperative application.

Software vendors may select different activation groups to isolate their programs from other vendor applications running in the same job. This vendor isolation is

shown in Figure 3-3 on page 3-4. In this figure, a complete customer solution is provided by integrating software packages from four different vendors. Activation groups increase the ease of integration by isolating the resources associated with each vendor package.

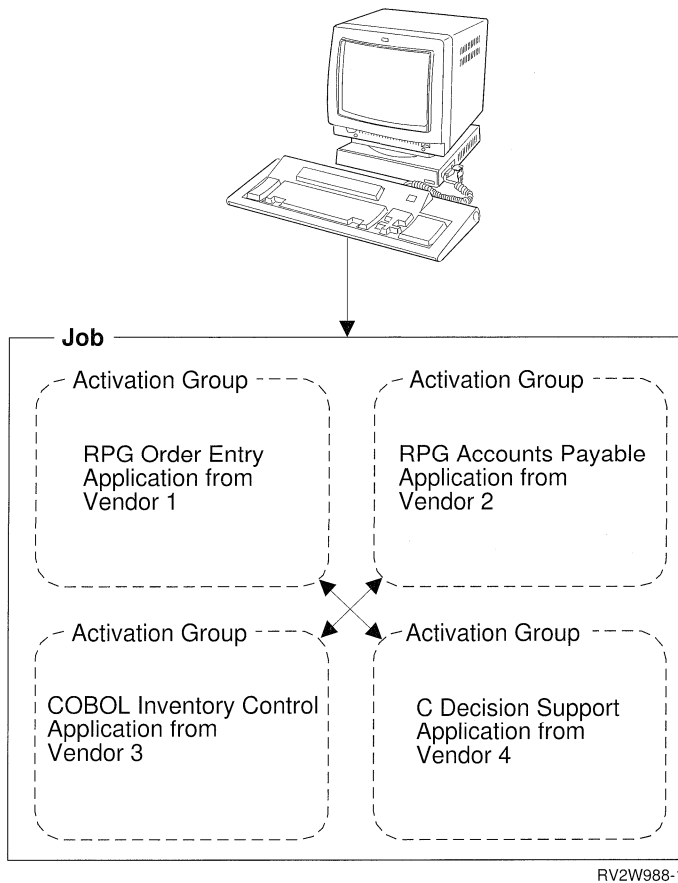

Figure 3-3. Activation Groups Isolate Each Vendor's Application

There is a significant consequence of assigning the above resources to an activation group. The consequence is that when an activation group is deleted, all of the above resources are returned to the system. The temporary data management resources left open at the time the activation group is deleted are closed by the system. The storage for static and automatic program variables and dynamic storage that has not been deallocated is returned to the system.

Activation Group Creation

You can control the creation of an ILE activation group by specifying an activation group attribute when you create your program or service program. Based on this attribute, an activation group is created by ILE as part of the dynamic program call processing. The attribute is specified by using the ACTGRP parameter on the CRTPGM command or CRTSRVPGM command. There is no Create Activation Group command.

All ILE programs have one of the following activation group attributes:

- A user-named activation group

Specified with the ACTGRP(name) parameter. This attribute allows you to manage a collection of ILE programs and ILE service programs as one applica-

tion. The activation group is created when it is first needed. It is then used by all programs and service programs that specify the same activation group name.

- A system-named activation group

Specified with the ACTGRP(*NEW) parameter on the CRTPGM command. This attribute allows you to create a new activation group whenever the program is called. ILE selects a name for this activation group. The name assigned by ILE is unique within your job. The name assigned to a system-named activation group does not match any name you choose for a user-named activation group. ILE service programs do not support this attribute.

- An attribute to use the activation group of the calling program

Specified with the ACTGRP(*CALLER) parameter. This attribute allows you to create an ILE program or ILE service program that will be activated within the activation group of the calling program. With this attribute, a new activation group is never created when the program or service program is activated.

All activation groups within a job have a name. Once an activation group exists within a job, it is used by ILE to activate programs and service programs that specify that name. As a result of this design, duplicate activation group names cannot exist within one job.

Default Activation Groups

When an OS/400 job is started, the system creates two activation groups to be used by OPM programs. One activation group is reserved for OS/400 system code. The other activation group is used for all other OPM programs. You cannot delete the OPM default activation groups. They are deleted by the system when your job ends.

ILE programs and ILE service programs can be activated in the OPM default activation groups if two conditions are satisfied:

- The ILE programs or ILE service programs were created with the activation group *CALLER option.
- The call to the ILE programs or ILE service programs originates in the OPM default activation groups.

Because the default activation groups cannot be deleted, your HLL end verbs cannot provide complete end processing. Open files cannot be closed, and storage used by your ILE programs cannot be returned to the system.

Figure 3-4 on page 3-6 shows a typical OS/400 job with an ILE activation group and the OPM default activation groups. The two OPM default activation groups are combined because the special value *DFTACTGRP is used to represent both groups. The boxes within each activation group represent program activations.

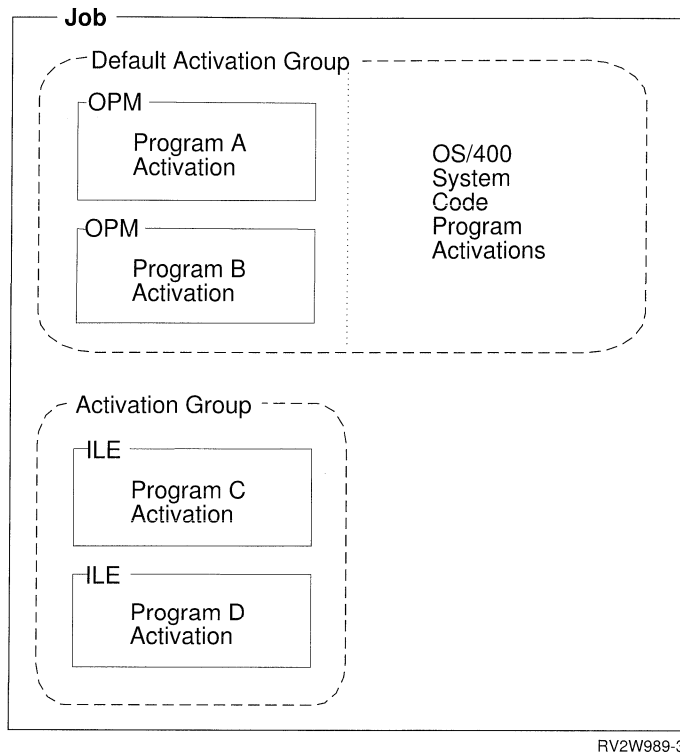

Figure 3-4. Default Activation Groups and ILE Activation Group

ILE Activation Group Deletion

Activation groups require resources to be created within a job. Processing time may be saved if an activation group can be reused by an application. ILE provides several options to allow you to return from the activation group without ending or deleting the activation group. Whether the activation group is deleted depends on the type of activation group and the method in which the application ended.

An application may leave an activation group and return to a call stack entry (see "Call Stack" on page 6-1) that is running in another activation group in the following ways:

- HLL end verbs
For example, STOP RUN in COBOL, exit() in C, or STOP in RPG.
- Unhandled exceptions
Unhandled exceptions can be moved by the system to a call stack entry in another activation group.
- Language-specific HLL return statements
For example, a return statement in C, an EXIT PROGRAM statement in COBOL, or a RETURN statement in RPG.
- Skip operations
For example, sending an exception message or branching to a call stack entry that is not in your activation group.

You can delete an activation group from your application by using HLL end verbs. An unhandled exception can also cause your activation group to be deleted. These

operations will always delete your activation group, provided the nearest control boundary is the oldest call stack entry in the activation group (sometimes called a hard control boundary). If the nearest control boundary is not the oldest call stack entry (sometimes called a soft control boundary), control passes to the call stack entry prior to the control boundary. However, the activation group is not deleted.

A control boundary is a call stack entry that represents a boundary to your application. ILE defines control boundaries whenever you call between activation groups. Refer to "Control Boundaries" on page 3-10 for a definition of a control boundary.

A user-named activation group may be left in the job for later use. For this type of activation group, any normal return or skip operation past a hard control boundary does not delete the activation group. The same operations used within a system-named activation group deletes the activation group. System-named activation groups are always deleted because you cannot reuse them by specifying the system-generated name. For language-dependent rules about a normal return from the oldest call stack entry of an activation group, refer to the ILE HLL programmer's guides.

Figure 3-5 shows examples of how to leave an activation group. In the figure, procedure P1 is the oldest call stack entry. For the system-named activation group (created with the ACTGRP(*NEW) option), a normal return from P1 deletes the activation group. For the user-named activation group (created with the ACTGRP(name) option), a normal return from P1 does not delete the activation group.

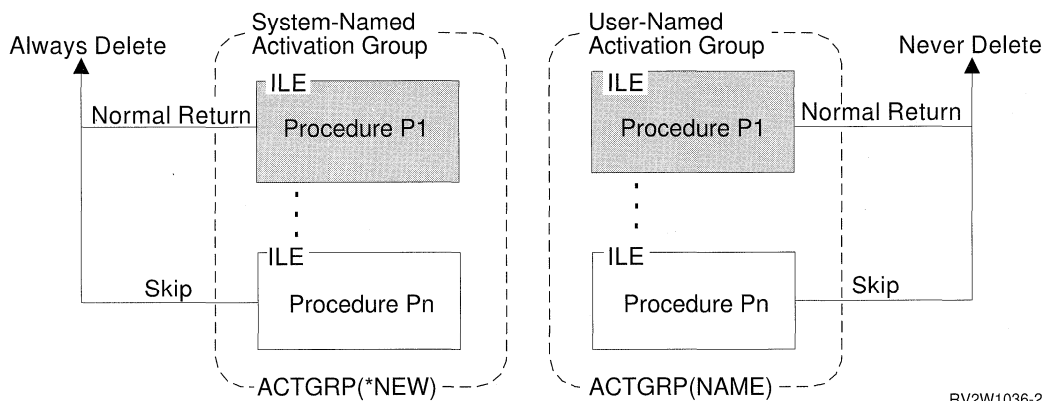
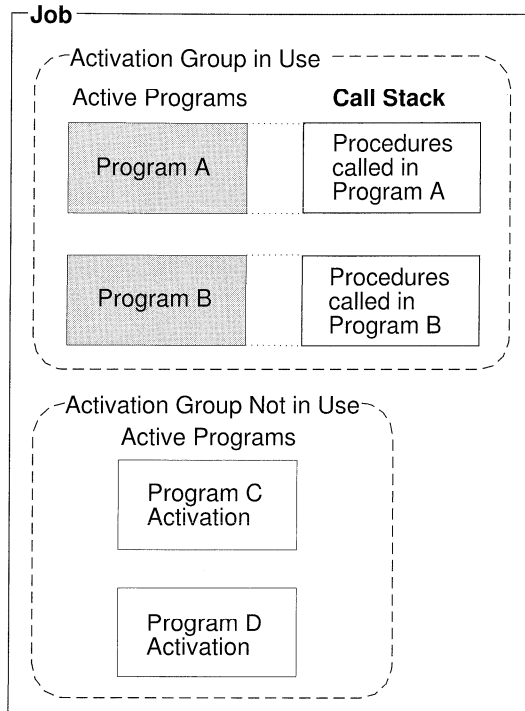

Figure 3-5. Leaving User-Named and System-Named Activation Groups

If a user-named activation group is left in the job, you can delete it by using the Reclaim Activation Group (RCLACTGRP) command. This command allows you to delete named activation groups after your application has returned. Only activation groups that are not in use can be deleted with this command.

Figure 3-6 on page 3-8 shows an OS/400 job with one activation group that is not in use and one activation group that is currently in use. An activation group is considered in use if there are call stack entries for the ILE procedures activated within that activation group. Using the RCLACTGRP command in program A or program B deletes the activation group for program C and program D.



RV2W990-4

Figure 3-6. Activation Groups In Use Have Entries on the Call Stack

When an activation group is deleted by ILE, certain end-operation processing occurs. This processing includes calling user-registered exit procedures, data management cleanup, and language cleanup (such as closing files). Refer to "Data Management Scoping Rules" on page 3-19 for details on the data management processing that occurs when an activation group is deleted.

Service Program Activation

This topic discusses the unique steps the system uses to activate a service program. The common steps used for programs and service programs are described in "Program Activation" on page 3-1. The following activation activities are unique for service programs:

- Service program activation starts indirectly as part of a dynamic program call to an ILE program.
- Service program activation includes completion of interprogram binding linkages by mapping the symbolic links into physical links.
- Service program activation includes signature check processing.

An ILE program activated for the first time within an activation group, is checked for binding to any ILE service programs. If service programs have been bound to the program being activated, they are also activated as part of the same dynamic call processing. This process is repeated until all necessary service programs are activated.

Figure 3-7 on page 3-9 shows ILE program A bound to ILE service programs B, C, and D. ILE service programs B and C are also bound to ILE service program E. The activation group attribute for each program and service program is shown.

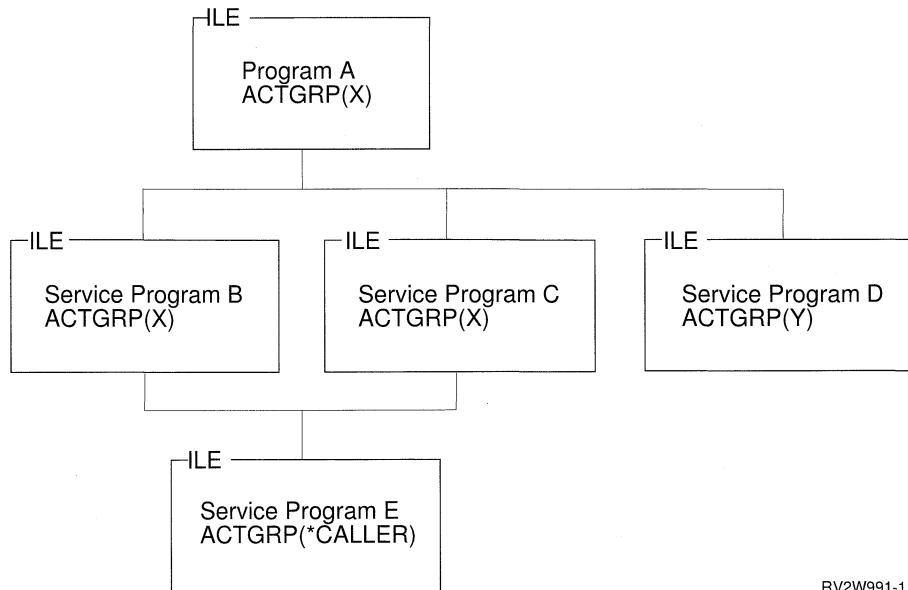

RV2W991-1

Figure 3-7. Service Program Activation

When ILE program A is activated, the following takes place:

- The service programs are located by using an explicit library name or by using the current library list. This option is controlled by you at the time the programs and service programs are created.
- Just like programs, a service program activation occurs only once within an activation group. In Figure 3-7, service program E is activated only one time, even though it is used by service programs B and C.
- A second activation group (Y) is created for service program D.
- Signature checking occurs among all of the programs and service programs.

Conceptually this process may be viewed as the completion of the binding process started when the programs and service programs were created. The CRTPGM command and CRTSRVPGM command saved the name and library of each referenced service program. An index into a table of exported procedures and data items was also saved in the client program or service program at program creation time. The process of service program activation completes the binding step by changing these symbolic references into addresses that can be used at run time.

Once a service program is activated static procedure calls and static data item references to a module within a different service program are processed. The amount of processing is the same as would be required if the modules had been bound by copy into the same program. However, modules bound by copy require less activation time processing than service programs.

The activation of programs and service programs requires execute authority to the ILE program and all ILE service program objects. In Figure 3-7, the current authority of the caller of program A is used to check authority to program A and all of the service programs. The authority of program A is also used to check authority to all of the service programs. Note that the authority of service program B, C, or D is not used to check authority to service program E.

Control Boundaries

ILE takes the following action when an unhandled function check occurs, or an HLL end verb is used. ILE transfers control to the caller of the call stack entry that represents a boundary for your application. This call stack entry is known as a **control boundary**.

There are two definitions for a control boundary. “Control Boundaries for ILE Activation Groups” and “Control Boundaries for the OPM Default Activation Group” on page 3-11 illustrate the following definitions.

A control boundary can be either of the following:

- Any ILE call stack entry for which the immediately preceding call stack entry is in a different nondefault activation group.
- Any ILE call stack entry for which the immediately preceding call stack entry is an OPM program.

Control Boundaries for ILE Activation Groups

This example shows how control boundaries are defined between ILE activation groups.

Figure 3-8 shows two ILE activation groups and the control boundaries established by the various calls. Procedures P2, P3, and P6 are potential control boundaries. For example, when you are running in procedure P7, procedure P6 is the control boundary. When you are running in procedures P4 or P5, procedure P3 becomes the control boundary.

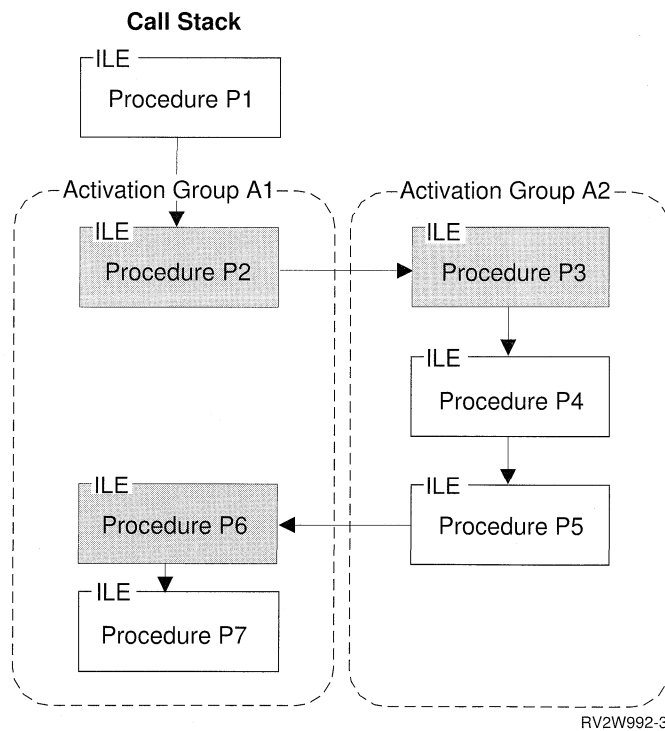

Figure 3-8. Control Boundaries. The shaded procedures are control boundaries.

Control Boundaries for the OPM Default Activation Group

This example shows how control boundaries are defined when an ILE program is running in the OPM default activation group.

Figure 3-9 shows three ILE procedures (P1, P2, and P3) running in the OPM default activation group. This example could have been created by using the CRTPGM command or CRTSRVPGM command with the ACTGRP(*CALLER) parameter value. Procedures P1 and P3 are potential control boundaries because the preceding call stack entries are OPM programs A and B.

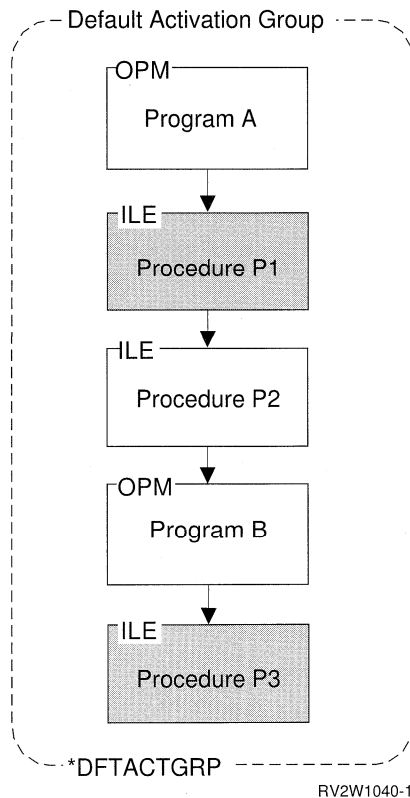

Figure 3-9. Control Boundaries in the Default Activation Group. The shaded procedures are control boundaries.

Control Boundary Use

When you use an ILE HLL end verb, ILE uses the most recent control boundary on the call stack to determine where to transfer control. The call stack entry just prior to the control boundary receives control after ILE completes all end processing.

The control boundary is used when an unhandled function check occurs within an ILE procedure. The control boundary defines the point on the call stack at which the unhandled function check is **promoted** to the generic ILE failure condition. For additional information, refer to “Error Handling” on page 3-12.

When the nearest control boundary is the oldest call stack entry in an ILE activation group, any HLL end verb or unhandled function check causes the activation group to be deleted. When the nearest control boundary is not the oldest call stack entry in an ILE activation group, control returns to the call stack entry just prior to the

control boundary. The activation group is not deleted because earlier call stack entries exist within the same activation group.

Figure 3-8 on page 3-10 shows procedure P2 and procedure P3 as the oldest call stack entries in their activation groups. Using an HLL end verb in procedure P2, P3, P4, or P5 (but not P6 or P7) would cause activation group A2 to be deleted.

Error Handling

This topic explains advanced error handling capabilities for OPM and ILE programs. To understand how these capabilities fit into the exception message architecture, refer to Figure 3-10. Specific reference information and additional concepts are found in Chapter 8, “Exception and Condition Management” on page 8-1. Figure 3-10 shows an overview of error handling. This topic starts with the bottom layer of this figure and continues to the top layer. The top layer represents the functions you may use to handle errors in an OPM or ILE program.

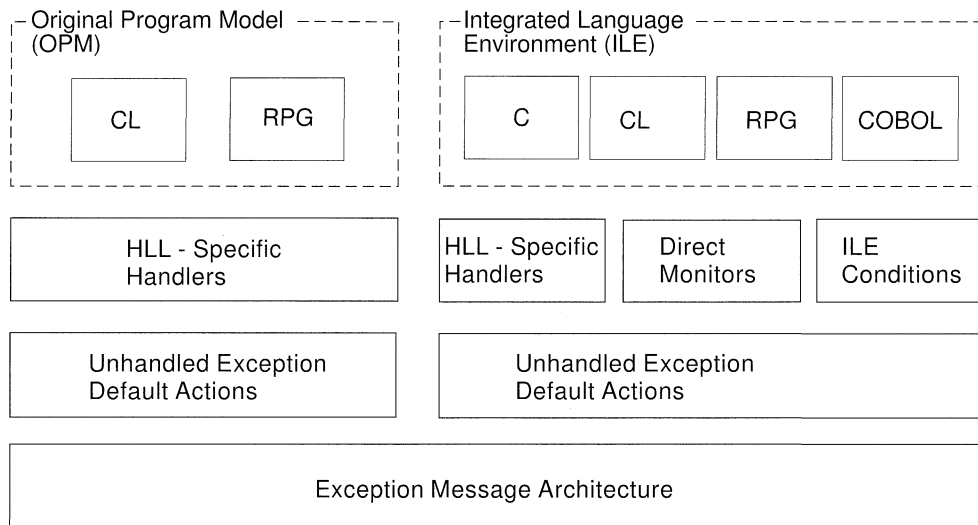

RV3W101-0

Figure 3-10. ILE and OPM Error Handling

Job Message Queues

A message queue exists for every call stack entry within each OS/400 job. This message queue facilitates the sending and receiving of informational messages and exception messages between the programs and procedures running on the call stack. The message queue is referred to as the **call message queue**.

The call message queue is identified by the name of the OPM program or ILE procedure that is on the call stack. The procedure name or program name can be used to specify the target call stack entry for the message that you send. Because ILE procedure names are not unique, the ILE module name and ILE program or service program name can optionally be specified. When the same program or procedure has multiple call stack entries, the nearest call message queue is used.

In addition to the call message queues, each OS/400 job contains one **external message queue**. All programs and procedures running within the job can send

and receive messages between an interactive job and the workstation user by using this queue.

For more information on how to send and receive exception messages, refer to the message handling APIs in the *System API Reference*.

Exception Messages and How They Are Sent

This topic describes the different exception message types and the ways in which an exception message may be sent.

Error handling for ILE and OPM is based on exception message types. Unless otherwise qualified, the term **exception message** indicates any of these message types:

- Escape (*ESCAPE)** Indicates an error causing a program to end abnormally, without completing its work. You will not receive control after sending an escape exception message.
- Status (*STATUS)** Describes the status of work being done by a program. You may receive control after sending this message type. Whether you receive control depends on the way the receiving program handles the status message.
- Notify (*NOTIFY)** Describes a condition requiring corrective action or a reply from the calling program. You may receive control after sending this message type. Whether you receive control depends on the way the receiving program handles the notify message.
- Function Check** Describes an ending condition that has not been expected by the program. An ILE function check is a special message type that is sent only by the system. An OPM function check is an escape message type with a message ID of CPF9999.

For information on these message types and other OS/400 message types, refer to the *System API Reference*.

An exception message is sent in the following ways:

- Generated by the system
OS/400 (including your HLL) generates an exception message to indicate a programming error or status information.
- Message handler API
The Send Program Message (QMHSNDPM) API can be used to send an exception message to a specific call message queue.
- ILE API
The Signal a Condition (CEESGL) bindable API can be used to raise an ILE condition. This condition results in an escape exception message or status exception message.
- Language-specific verbs
For ILE C/400, the raise() function generates a C signal. Neither ILE RPG/400 nor ILE COBOL/400 has a similar function.

How Exception Messages Are Handled

When you or the system send an exception message, exception processing begins. This processing continues until the exception is handled, which is when the exception message is modified to indicate that it has been handled.

The system modifies the exception message to indicate that it has been handled when it calls an exception handler for an OPM call message queue. Your ILE HLL modifies the exception message before your exception handler is called for an ILE call message queue. As a result, HLL-specific error handling considers the exception message handled when your handler is called. If you do not use HLL-specific error handling, your ILE HLL can either handle the exception message or allow exception processing to continue. Refer to your ILE HLL reference manual to determine your HLL default actions for unhandled exception messages.

To allow you to bypass language-specific error handling, additional capabilities are defined for ILE. These capabilities include direct monitor handlers and ILE condition handlers. When you use these capabilities, you are responsible for modifying the exception message to indicate that the exception is handled. If you do not modify the exception message, the system continues exception processing by attempting to locate another exception handler. The topic “Types of Exception Handlers” on page 3-16 contains details on direct monitor handlers and ILE condition handlers. To modify an exception message, refer to the Change Exception Message (QMHCHGEM) API in the *System API Reference*.

Exception Recovery

You may want to continue processing after an exception has been sent. Recovering from an error can be a useful application tool that allows you to deliver applications that tolerate errors. For ILE and OPM programs, the system has defined the concept of a **resume point**. The resume point is initially set to an instruction immediately following the occurrence of the exception. After handling an exception, you may continue processing at a resume point. For more information on how to use and modify a resume point, refer to Chapter 8, “Exception and Condition Management” on page 8-1.

Default Actions for Unhandled Exceptions

If you do not handle an exception message in your HLL, the system takes a default action for the unhandled exception.

Figure 3-10 on page 3-12 shows the default actions for unhandled exceptions based on whether the exception was sent to an OPM or ILE program. Different default actions for OPM and ILE create a fundamental difference in error handling capabilities.

For OPM, an unhandled exception generates a special escape message known as a function check message. This message is given the special message ID of CPF9999. It is sent to the call message queue of the call stack entry that incurred the original exception message. If the function check message is not handled, the system removes that call stack entry. The system then sends the function check message to the previous call stack entry. This process continues until the function check message is handled. If the function check message is never handled, the job ends.

For ILE, an unhandled exception message is percolated to the previous call stack entry message queue. **Percolation** occurs when the exception message is moved to the previous call message queue. This creates the effect of sending the same exception message to the previous call message queue. When this happens, exception processing continues at the previous call stack entry.

Figure 3-11 on page 3-16 shows unhandled exception messages within ILE. In this example, procedure P1 is a control boundary. Procedure P1 is also the oldest call stack entry in the activation group. Procedure P4 incurred an exception message that was unhandled. Percolation of an unhandled exception continues until either a control boundary is reached or the exception message is handled. An unhandled exception is converted to a function check when it is percolated to the control boundary. If the exception is an escape, the function check is generated. If it is a notify exception, the default reply is sent, the exception is handled, and the sender of the notify is allowed to continue. If it is a status exception, the exception is handled, and the sender of the status is allowed to continue. The resume point (shown in procedure P3) is used to define the call stack entry at which exception processing of the function check should continue. For ILE, the next processing step is to send the special function check exception message to this call stack entry. This is procedure P3 in this example.

The function check exception message can now be handled or percolated to the control boundary. If it is handled, normal processing continues and exception processing ends. If the function check message is percolated to the control boundary, ILE considers the application to have ended with an unexpected error. A generic failure exception message is defined by ILE for all languages. This message is CEE9901 and is sent by ILE to the caller of the control boundary.

The default action for unhandled exception messages defined in ILE allows you to recover from error conditions that occur within a mixed-language application. For unexpected errors, ILE enforces a consistent failure message for all languages. This improves the ability to integrate applications from different sources.

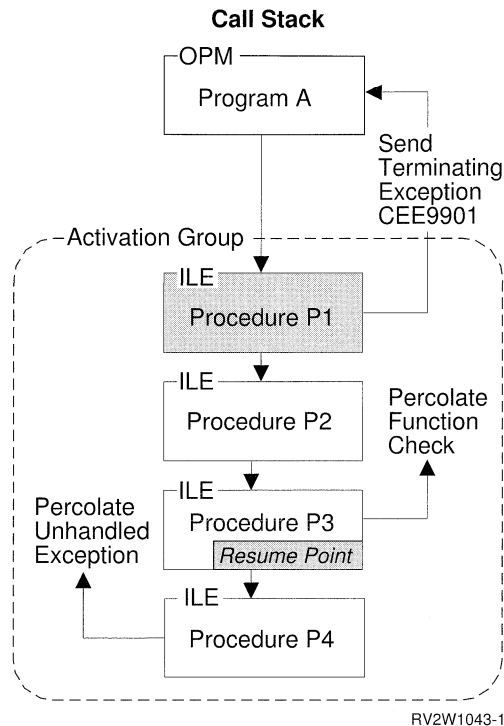

Figure 3-11. Unhandled Exception Default Action

Types of Exception Handlers

This topic provides an overview of the exception handler types provided for both OPM and ILE programs. As shown in Figure 3-10 on page 3-12, this is the top layer of the exception message architecture. ILE provides additional exception-handling capabilities when compared to OPM.

For OPM programs, HLL-specific error handling provides one or more handling routines for each call stack entry. The appropriate routine is called by the system when an exception is sent to an OPM program.

HLL-specific error handling in ILE provides the same capabilities. ILE, however, has additional types of exception handlers. These types of handlers give you direct control of the exception message architecture and allow you to bypass HLL-specific error handling. The additional types of handlers for ILE are:

- Direct monitor handler
- ILE condition handler

To determine if these types of handlers are supported by your HLL, refer to your ILE HLL programmer's guide.

Direct monitor handlers allow you to directly declare an exception monitor around limited HLL source statements. For ILE C/400, this capability is enabled through a `#pragma` directive. ILE COBOL/400 does not directly declare an exception monitor around limited HLL source statements in the same sense that ILE C/400 does. An ILE COBOL/400 program cannot directly code the enablement and disablement of handlers around arbitrary source code. However, a statement such as

```
ADD a TO b ON SIZE ERROR imperative
```

is internally mapped to use the same mechanism. Thus, in terms of the priority of which handler gets control first, such a statement-scoped conditional imperative gets control before the ILE condition handler (registered via CEEHDLR). Control then proceeds to the USE declaratives in COBOL.

ILE condition handlers allow you to **register** an exception handler at run time. ILE condition handlers are registered for a particular call stack entry. To register an ILE condition handler, use the Register a User-Written Condition Handler (CEEHDLR) bindable API. This API allows you to identify a procedure at run time that should be given control when an exception occurs. The CEEHDLR API requires the ability to declare and set a procedure pointer within your language. CEEHDLR is implemented as a built-in function. Therefore, its address cannot be specified and it cannot be called through a procedure pointer. ILE condition handlers may be **unregistered** by calling the Unregister a User-Written Condition Handler (CEEHDLU) bindable API.

OPM and ILE support HLL-specific handlers. **HLL-specific handlers** are the language features defined for handling errors. For example, the ILE C/400 signal function can be used to handle exception messages. HLL-specific error handling in RPG includes the ability to code *PSSR and INFSR subroutines. HLL-specific error handling in COBOL includes USE declarative for I/O error handling and imperatives in statement-scoped condition phrases such as ON SIZE ERROR and AT INVALID KEY.

Exception handler priority becomes important if you use both HLL-specific error handling and additional ILE exception handler types.

Figure 3-12 on page 3-18 shows a call stack entry for procedure P2. In this example, all three types of handlers have been defined for a single call stack entry. Though this may not be a typical example, it is possible to have all three types defined. Because all three types are defined, an exception handler priority is defined. The figure shows this priority. When an exception message is sent, the exception handlers are called in the following order:

1. Direct monitor handlers

First the invocation is chosen, then the relative order of handlers in that invocation. Within an invocation, all direct monitor handlers and COBOL statement-scoped conditional imperatives get control before the ILE condition handlers. Similarly, the ILE condition handlers get control before other HLL-specific handlers.

If direct monitor handlers have been declared around the statements that incurred the exception, these handlers are called before HLL-specific handlers. For example, if procedure P2 in Figure 3-12 on page 3-18 has a HLL-specific handler and procedure P1 has a direct monitor handler, P2's handler is considered before P1's direct monitor handler.

Direct monitors can be lexically nested. The handler specified in the most deeply nested direct monitor is chosen first within the multiply nested monitors that specify the same priority number.

2. ILE condition handler

If an ILE condition handler has been registered for the call stack entry, this handler is called second. Multiple ILE condition handlers may be registered. In the example, procedure P5 and procedure P6 are ILE condition handlers.

When multiple ILE condition handlers are registered for the same call stack entry, the system calls these handlers in last-in-first-out (LIFO) order. If we categorize COBOL statement-scoped conditional imperatives as HLL-specific handlers, those imperatives take priority over the ILE condition handler.

3. HLL-specific handler

HLL-specific handlers are called last.

The system ends exception processing when an exception message is modified to show that it has been handled. If you are using direct monitor handlers or ILE condition handlers, modifying the exception message is your responsibility. Several control actions are available. For example, you can specify handle as a control action. As long as the exception message remains unhandled, the system continues to search for an exception handler using the priorities previously defined. If the exception is not handled within the current call stack entry, percolation to the previous call stack entry occurs. If you do not use HLL-specific error handling, your ILE HLL can choose to allow exception handling to continue at the previous call stack entry.

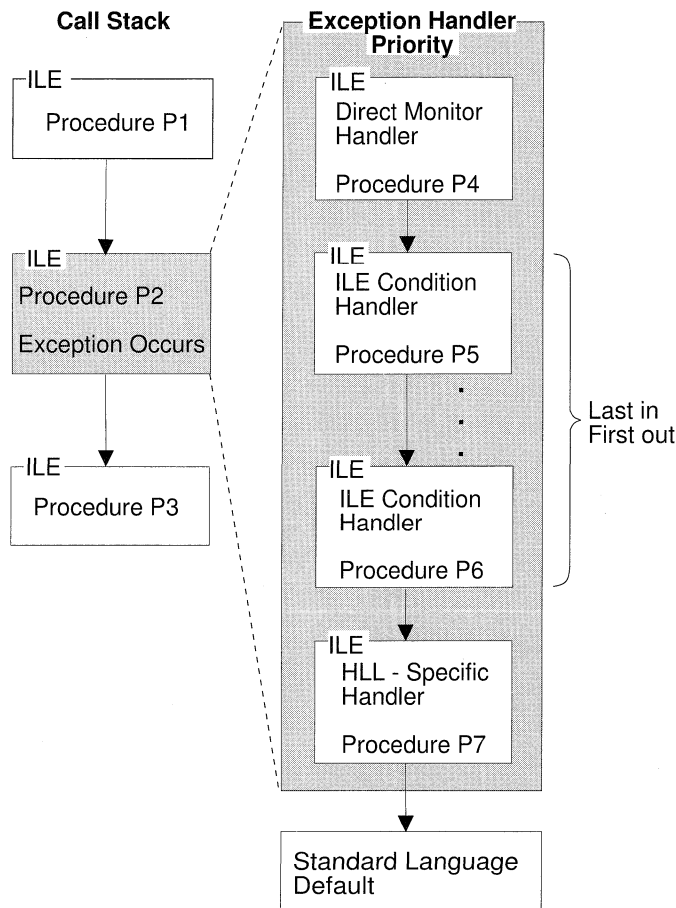

RV2W1041-3

Figure 3-12. Exception Handler Priority

ILE Conditions

To allow greater cross-system consistency, ILE has defined a feature that allows you to work with error conditions. An ILE **condition** is a system-independent representation of an error condition within an HLL. For the OS/400 operating system, each ILE condition has a corresponding exception message. An ILE condition is represented by a condition token. A **condition token** is a 12-byte data structure that is consistent across multiple SAA participating systems. This data structure contains information that allows you to associate the condition with the underlying exception message.

ILE condition handlers and the percolation model described previously conform to an SAA architecture. To write programs that are consistent across systems, you need to use ILE condition handlers and ILE condition tokens. For more information on ILE conditions refer to Chapter 8, "Exception and Condition Management" on page 8-1.

Data Management Scoping Rules

Data management scoping rules control the use of data management resources. These resources are temporary objects that allow a program to work with data management. For example, when a program opens a file, an object called an open data path (ODP) is created to connect the program to the file. When a program creates an override to change how a file should be processed, the system creates an override object.

Data management scoping rules determine when a resource can be shared by multiple programs or procedures running on the call stack. For example, open files created with the SHARE(*YES) parameter value or commitment definition objects can be used by many programs at the same time. The ability to share a data management resource depends on the level of scoping for the data management resource.

Data management scoping rules also determine the existence of the resource. The system automatically deletes unused resources within the job, depending on the scoping rules. As a result of this automatic cleanup operation, the job uses less storage and job performance improves.

ILE formalizes the data management scoping rules for both OPM and ILE programs into the following scoping levels:

- Call
- Activation group
- Job

Depending on the data management resource you are using, one or more of the scoping levels may be explicitly specified. If you do not select a scoping level, the system selects one of the levels as a default.

Refer to Chapter 10, "Data Management Scoping" on page 10-1 for information on how each data management resource supports the scoping levels. For additional details, refer to the *Data Management* book.

Call-Level Scoping

Call-level scoping occurs when the data management resource is connected to the call stack entry that created the resource. Figure 3-13 shows an example. Call-level scoping is usually the default scoping level for programs that run in the default activation group. In this figure, OPM program A, OPM program B, or ILE procedure P2 may choose to return without closing their respective files F1, F2, or F3. Data management associates the ODP for each file with the call-level number that opened the file. The RCLRSC command may be used to close the files based on a particular call-level number passed to that command.

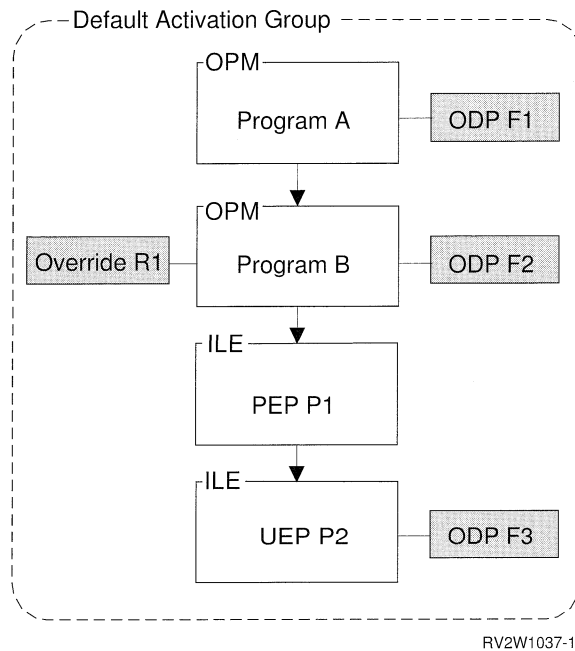

Figure 3-13. Call-Level Scoping. ODPs and overrides may be scoped to the call level.

Overrides that are scoped to a particular call level are deleted when the corresponding call stack entry returns. Overrides may be shared by any call stack entry that is below the call level that created the override.

Activation-Group-Level Scoping

Activation-group-level scoping occurs when the data management resource is connected to the activation group of the ILE program or ILE service program that created the resource. When the activation group is deleted, data management closes all resources associated with the activation group that have been left open by programs running in the activation group.

Figure 3-14 shows an example of activation-group-level scoping. Activation-group-level scoping is the default scoping level for most types of data management resources used by ILE procedures not running in the default activation group. For example, the figure shows ODPs for files F1, F2, and F3 and override R1 scoped to the activation group.

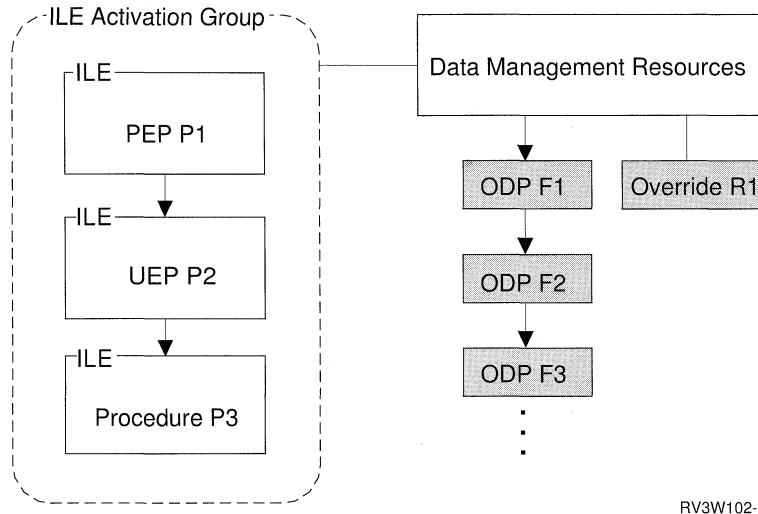

RV3W102-0

Figure 3-14. Activation Group Level Scoping. ODPs and overrides may be scoped to an activation group.

The ability to share a data management resource scoped to an activation group is limited to programs running in that activation group. This provides application isolation and protection. For example, assume that file F1 in the figure was opened with the SHARE(*YES) parameter value. File F1 could be used by any ILE procedure running in the same activation group. Another open operation for file F1 in a different activation group results in the creation of a second ODP for that file.

Job-Level Scoping

Job-level scoping occurs when the data management resource is connected to the job. Job-level scoping is available to both OPM and ILE programs. Job-level scoping allows for sharing data management resources between programs running in different activation groups. As described in the previous topic, scoping resources to an activation group limits the sharing of that resource to programs running in that activation group. Job-level scoping allows the sharing of data management resources between all ILE and OPM programs running in the job.

Figure 3-15 on page 3-22 shows an example of job-level scoping. Program A may have opened file F1, specifying job-level scoping. The ODP for this file is connected to the job. The file is not closed by the system unless the job ends. If the ODP has been created with the SHARE(YES) parameter value, any OPM program or ILE procedure could potentially share the file.

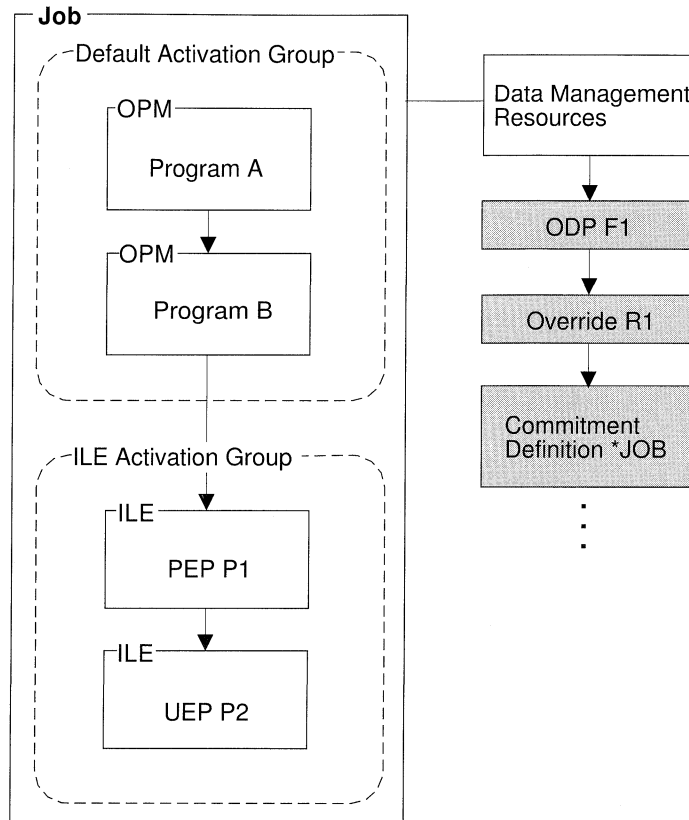

RV2W1039-2

Figure 3-15. Job Level Scoping. ODPs, overrides, and commitment definitions may be scoped to the job level.

Overrides scoped to the job level influence all open file operations in the job. In this example, override R1 could have been created by procedure P2. A job-level override remains active until it is either explicitly deleted or the job ends. The job-level override is the highest priority override when merging occurs. This is because call-level overrides are merged together when multiple overrides exist on the call stack.

Data management scoping levels may be explicitly specified by the use of scoping parameters on override commands, commitment control commands, and through various APIs. The complete list of data management resources that use the scoping rules are in Chapter 10, "Data Management Scoping" on page 10-1.

Chapter 4. Program Creation Concepts

The process for creating ILE programs or service programs gives you greater flexibility and control in designing and maintaining applications. The process includes two steps:

1. Compiling source code into modules.
2. Binding modules into an ILE program or service program. Binding occurs when the Create Program (CRTPGM) or Create Service Program (CRTSRVPGM) command is run.

This chapter explains concepts associated with the binder and with the process of creating ILE programs or service programs. Before reading this chapter, you should be familiar with the binding concepts described in Chapter 2, "ILE Basic Concepts" on page 2-1.

Create Program and Create Service Program Commands

The Create Program (CRTPGM) and Create Service Program (CRTSRVPGM) commands look similar and share many of the same parameters. Comparing the parameters used in the two commands helps to clarify how each command can be used.

Table 4-1 shows the commands and their parameters with the default values supplied.

Table 4-1. Parameters for CRTPGM and CRTSRVPGM Commands

Parameter Group	CRTPGM Command	CRTSRVPGM Command
Identification	PGM(*CURLIB/WORK) MODULE(*PGM)	SRVPGM(*CURLIB/UTILITY) MODULE(*SRVPGM)
Program access	ENTMOD(*FIRST)	EXPORT(*SRCFILE) SRCFILE(*LIBL/QSRVSRC) SRCMBR(*SRVPGM)
Binding	BNSRVPGM(*NONE) BNDDIR(*NONE)	BNSRVPGM(*NONE) BNDDIR(*NONE)
Run time	ACTGRP(*NEW)	ACTGRP(*CALLER)
Miscellaneous	OPTION(*GEN *NODUPPROC *NODUPVAR *WARN *RSLVREF) DETAIL(*NONE) ALWUPD(*YES) ALWRINZ(*NO) REPLACE(*YES) AUT(*LIBCRTAUT) TEXT(*ENTMODTXT) TGTRLS(*CURRENT) USRPRF(*USER)	OPTION(*GEN *NODUPPROC *NODUPVAR *WARN *RSLVREF) DETAIL(*NONE) ALWUPD(*YES) ALWRINZ(*NO) REPLACE(*YES) AUT(*LIBCRTAUT) TEXT(*ENTMODTXT) TGTRLS(*CURRENT) USRPRF(*USER)

The identification parameters for both commands name the object to be created and the modules copied. The only difference in the two parameters is in the default

module name to use when creating the object. For CRTPGM, use the same name for the module as is specified on the program (*PGM) parameter. For CRTSRVPGM, use the same name for the module as is specified on the service program (*SRVPGM) parameter. Otherwise, these parameters look and act the same.

The most significant similarity in the two commands is how the binder resolves symbols between the imports and exports. In both cases, the binder processes the input from the module (MODULE), bound service program (BNDSRVPGM), and binding directory (BNDDIR) parameters.

The most significant difference in the commands is with the program-access parameters (see “Program Access” on page 4-8). For the CRTPGM command, all that needs to be identified to the binder is which module has the program entry procedure. Once the program is created and a dynamic program call is made to this program, processing starts with the module containing the program entry procedure. The CRTSRVPGM command needs more program-access information because it can supply an interface of several access points for other programs or service programs.

Symbol Resolution

Symbol resolution is the process the binder goes through to match the following:

- The import requests from the set of modules to be bound by copy
- The set of exports provided by the specified modules and service programs

The set of exports to be used during symbol resolution can be thought of as an ordered (sequentially numbered) list. The order of the exports is determined by the following:

- The order in which the objects are specified on the MODULE, BNDSRVPGM, and BNDDIR parameters of the CRTPGM or CRTSRVPGM command
- The exports from the language run-time routines of the specified modules

Resolved and Unresolved Imports

An import and export each consist of a procedure or data type and a name. An **unresolved import** is one whose type and name do not yet match the type and name of an export. A **resolved import** is one whose type and name exactly match the type and name of an export.

Only the imports from the modules that are bound by copy go into the unresolved import list. During symbol resolution, the next unresolved import is used to search the ordered list of exports for a match. If an unresolved import exists after checking the set of ordered exports, the program object or service program is normally not created. However, if *UNRSLVREF is specified on the option parameter, a program object or service program with unresolved imports can be created. If such a program object or service program tries to use an unresolved import at run time, the following occurs:

- If the program object or service program was created or updated for a Version 2 Release 3 system, error message MCH3203 is issued. That message says, “Function error in machine instruction.”

- If the program object or service program was created or updated for a Version 3 Release 1 system, error message MCH4439 is issued. That message says, “Attempt to use an import that was not resolved.”

Binding by Copy

The modules specified on the MODULE parameter are always bound by copy. Modules named in a binding directory specified by the BNDDIR parameter are bound by copy if they are needed. A module named in a binding directory is needed in either of the following cases:

- The module provides an export for an unresolved import
- The module provides an export named in the current export block of the binder language source file being used to create a service program

If an export found in the binder language comes from a module object, that module is always bound by copy, regardless of whether it was explicitly provided on the command line or comes from a binding directory. For example,

```
Module M1: imports P2
Module M2: exports P2
Module M3: exports P3
Binder language S1: STRPGMEXP PGMLVL(*CURRENT)
                   EXPORT P3
                   ENDPGMEXP
Binding directory BNDDIR1: M2
                           M3
CRTSRVPGM SRVPGM(MYLIB/SRV1) MODULE(MYLIB/M1) SRCFILE(MYLIB/S1)
                   SRCMBR(S1) BNDDIR(MYLIB/BNDDIR1)
```

Service program SRV1 will have three modules: M1, M2, and M3. M3 is copied because P3 is in the current export block.

Binding by Reference

Service programs specified on the BNDSRVPGM parameter are bound by reference. If a service program named in a binding directory provides an export for an unresolved import, that service program is bound by reference. A service program bound in this way does not add new imports.

Importance of the Order of Exports

With only a slight change to the command, you can create a different, but potentially equally valid, program. The order in which objects are specified on the MODULE, BNDSRVPGM, and BNDDIR parameters is usually important only if both of the following are true:

- Multiple modules or service programs are exporting duplicate symbol names
- Another module needs to import the symbol name

Most applications do not have duplicate symbols, and programmers seldom need to worry about the order in which the objects are specified. For those applications that have duplicate symbols exported that are also imported, consider the order in which objects are listed on CRTPGM or CRTSRVPGM commands.

The following examples show how symbol resolution works. The modules, service programs, and binding directories in Figure 4-1 on page 4-4 are used for the

CRTPGM requests in Figure 4-2 on page 4-5 and Figure 4-3 on page 4-7. Assume that all the identified exports and imports are procedures.

The examples also show the role of binding directories in the program-creation process. Assume that library MYLIB is in the library list for the CRTPGM and CRTSRVPGM commands. The following command creates binding directory L in library MYLIB:

```
CRTBNDDIR BNDDIR(MYLIB/L)
```

The following command adds the names of modules M1 and M2 and of service programs S and T to binding directory L:

```
ADDBNDIRE BNDDIR(MYLIB/L) OBJ((M1 *MODULE) (M2 *MODULE) (S) (T))
```

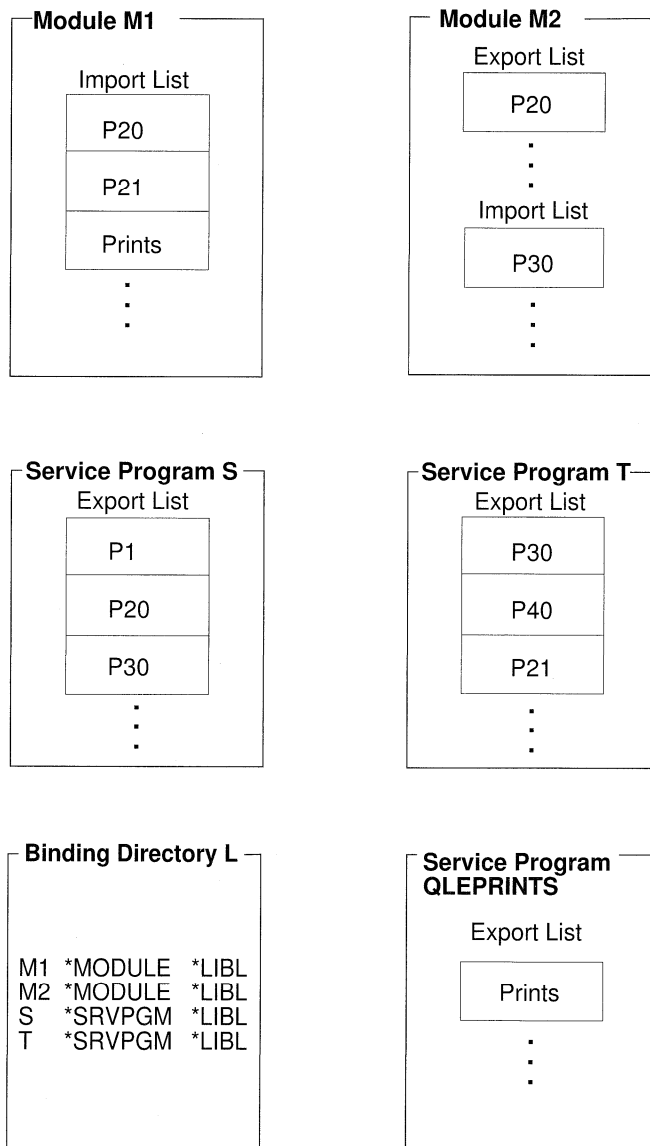

RV2W1054-3

Figure 4-1. Modules, Service Programs, and Binding Directory

Program Creation Example 1

Assume that the following command is used to create program A in Figure 4-2:

```
CRTPGM PGM(TEST/A)
MODULE(*LIBL/M1)
BNDSRVPGM(*LIBL/S)
BNDDIR(*LIBL/L)
OPTION(*DUPPROC)
```

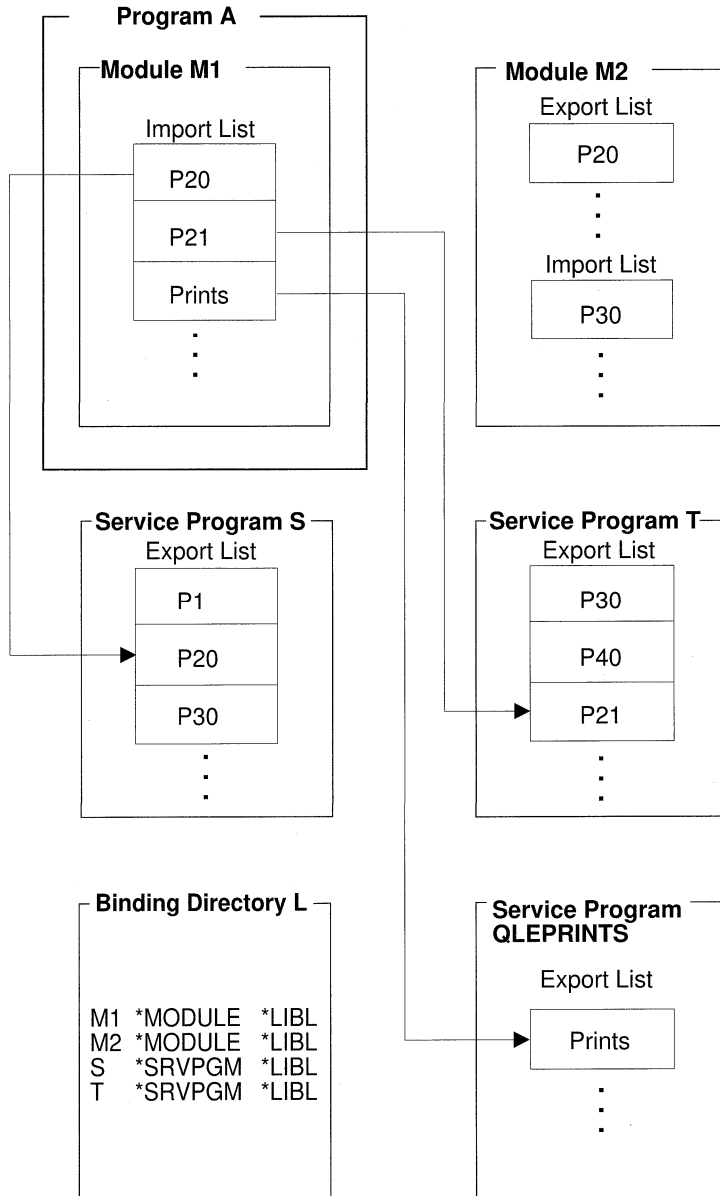

RV2W1049-4

Figure 4-2. Symbol Resolution and Program Creation: Example 1

To create program A, the binder processes objects specified on the CRTPGM command parameters in the order specified:

1. The value specified on the first parameter (PGM) is A, which is the name of the program to be created.

2. The value specified on the second parameter (module) is M1. The binder starts there. Module M1 contains three imports that need to be resolved: P20, P21, and Prints.
3. The value specified on the third parameter (BNDSRVPGM) is S. The binder scans the export list of service program S for any procedures that resolve any unresolved import requests. Because the export list contains procedure P20, that import request is resolved.
4. The value specified on the fourth parameter (BNDDIR) is L. The binder next scans binding directory L.
 - a. The first object specified in the binding directory is module M1. Module M1 is currently known because it was specified on the module parameter, but it does not provide any exports.
 - b. The second object specified in the binding directory is module M2. Module M2 provides exports, but none of them match any currently unresolved import requests (P21 and Prints).
 - c. The third object specified in the binding directory is service program S. Service program S was already processed in step 3 and does not provide any additional exports.
 - d. The fourth object specified in the binding directory is service program T. The binder scans the export list of service program T. Procedure P21 is found, which resolves that import request.
5. The final import that needs to be resolved (Prints) is not specified on any parameter. Nevertheless, the binder finds the Prints procedure in the export list of service program QLEPRINTS, which is a common run-time routine provided by the compiler in this example. When compiling a module, the compiler specifies as the default the binding directory containing its own run-time service programs and the ILE run-time service programs. That is how the binder knows that it should look for any remaining unresolved references in the run-time service programs provided by the compiler. If, after the binder looks in the run-time service programs, there are references that cannot be resolved, the bind normally fails. However, if you specify OPTION(*UNRSLVREF) on the create command, the program is created.

Program Creation Example 2

Figure 4-3 shows the result of a similar CRTPGM request, except that the service program on the BNDSRVPGM parameter has been removed:

```
CRTPGM PGM(TEST/A)
      MODULE(*LIBL/M1)
      BNDDIR(*LIBL/L)
      OPTION(*DUPPROC)
```

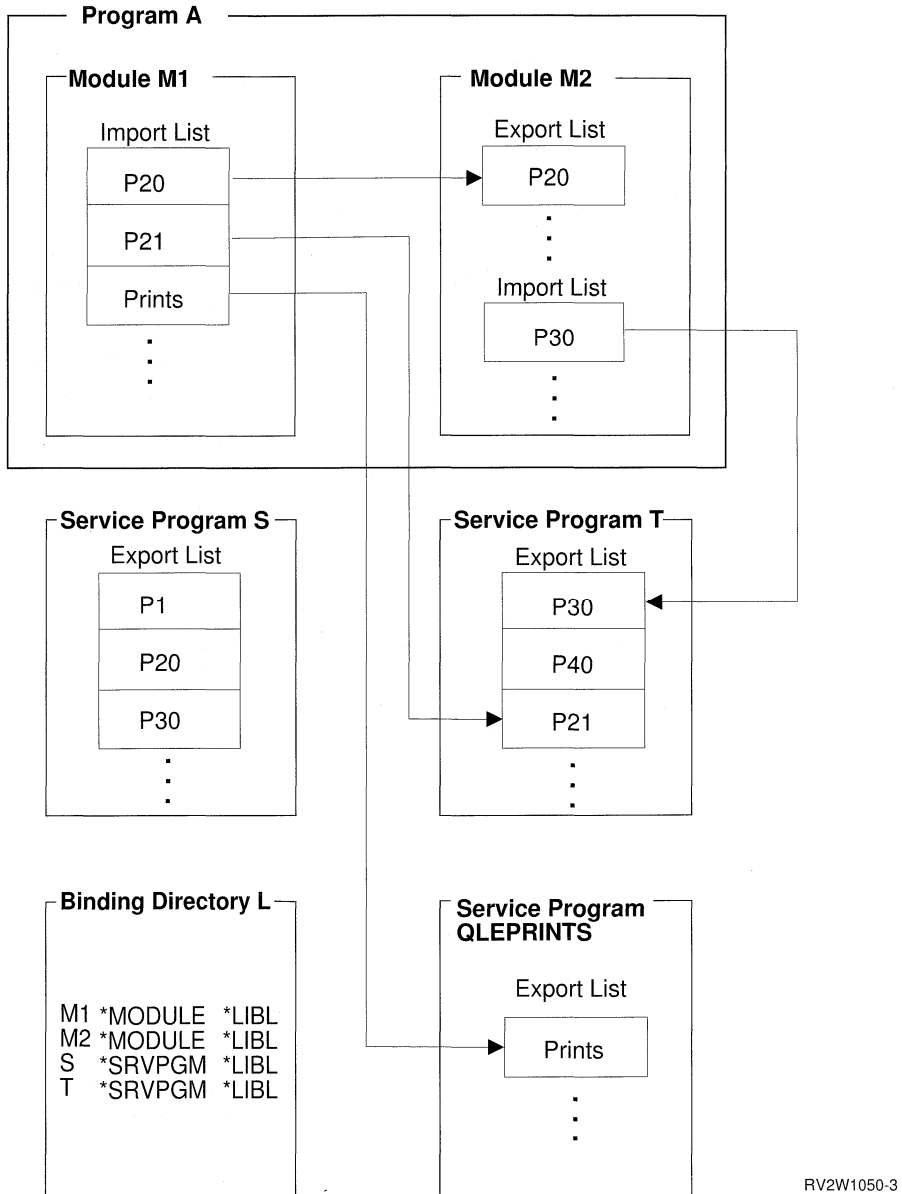

Figure 4-3. Symbol Resolution and Program Creation: Example 2

The change in ordering of the objects to be processed changes the ordering of the exports. It also results in the creation of a program that is different from the program created in example 1. Because service program S is not specified on the BNDSRVPGM parameter of the CRTPGM command, the binding directory is processed. Module M2 exports procedure P20 and is specified in the binding directory ahead of service program S. Therefore, module M2 gets copied to the resulting

program object in this example. When you compare Figure 4-2 on page 4-5 with Figure 4-3 you see the following:

- Program A in example 1 contains only module M1 and uses procedures from service programs S, T, and QLEPRINTS.
- In program A of example 2, two modules called M1 and M2 use service programs T and QLEPRINTS.

The program in example 2 is created as follows:

1. The first parameter (PGM) specifies the name of the program to be created.
2. The value specified on the second parameter (MODULE) is M1, so the binder again starts there. Module M1 contains the same three imports that need to be resolved: P20, P21, and Prints.
3. This time, the third parameter specified is not BNDSRVPGM. It is BNDDIR. Therefore, the binder first scans the binding directory specified (L).
 - a. The first entry specified in the binding directory is module M1. Module M1 from this library was already processed by the module parameter.
 - b. The second entry specified in the binding directory is for module M2. The binder scans the export list of module M2. Because that export list contains P20, that import request is resolved. Module M2 is bound by copy and its imports must be added to the list of unresolved import requests for processing. The unresolved import requests are now P21, Prints, and P30.
 - c. Processing continues to the next object specified in the binding directory, which is service program S. In this case, service program S does not provide any exports for currently unresolved import requests. Processing continues to the next object listed in the binding directory.
4. Service program T provides exports P21 and P30 for the unresolved imports.
5. As in example 1, import request Prints is not specified. However, the procedure is found in the run-time routines provided by the language in which module M1 was written.

Symbol resolution is also affected by the strength of the exports. For information about strong and weak exports, see Export in “Binder Information Listing for Example Service Program” on page A-7.

Program Access

When you create an ILE program object or service program object, you need to specify how other programs can access that program. On the CRTPGM command, you do so with the entry module (ENTMOD) parameter. On the CRTSRVPGM command, you do so with the export (EXPORT) parameter (see Table 4-1 on page 4-1).

Entry Module Parameter on the CRTPGM Command

The entry module (ENTMOD) parameter tells the binder the name of the module in which the following are located:

- Program entry procedure (PEP)
- User entry procedure (UEP)

This information identifies which module contains the PEP that gets control when a dynamic call is made to the program being created.

The default value for the ENTMOD parameter is *FIRST. This value specifies that the binder uses as the entry module the first module it finds in the list of modules specified on the module parameter that contains a PEP.

If the following conditions exist:

- *FIRST is specified on the ENTMOD parameter
- A second module with a PEP is encountered

the binder copies this second module into the program object and continues the binding process. The binder ignores the additional PEP.

If *ONLY is specified on the ENTMOD parameter, only one module in the program can contain a PEP. If *ONLY is specified and a second module with a PEP is encountered, the object is not created.

For explicit control, you can specify the name of the module that contains the PEP. Any other PEPs are ignored. If the module explicitly specified does not contain a PEP, the CRTPGM request fails.

To see whether a module has a program entry procedure, you use the display module (DSPMOD) command. The information appears in the *Program entry procedure name* field of the Display Module Information display. If *NONE is specified in the field, this module does not have a PEP. If a name is specified in the field, this module has a PEP.

Export Parameter on the CRTSRVPGM Command

The export (EXPORT), source file (SRCFILE), and source member (SRCMBR) parameters identify the public interface to the service program being created. The parameters specify the exports (procedures and data) that a service program makes available for use by other ILE programs or service programs.

The default value for the export parameter is *SRCFILE. That value directs the binder to the SRCFILE parameter for a reference to information about exports of the service program. This additional information is a source file with binder language source in it (see “Binder Language” on page 4-10). The binder locates the binder language source and, from the specified names to be exported, generates one or more signatures. The binder language also allows you to specify a signature of your choice instead of having the binder generate one.

The other possible value for the export parameter is *ALL. When EXPORT(*ALL) is specified, all of the symbols exported from the copied modules are exported from the service program. The signature that gets generated is determined by the following:

- The number of exported symbols
- Alphabetical order of exported symbols

If EXPORT(*ALL) is specified, no binder language is needed to define the exports from a service program. This value is the easiest one to use because you do not have to generate the binder language source. However, a service program with EXPORT(*ALL) specified can be difficult to update or correct once the exports are used by other programs. If the service program is changed, the order or number of

exports could change. Therefore, the signature of that service program could change. If the signature changes, all programs or service programs that use the changed service program have to be re-created.

EXPORT(*ALL) indicates that all symbols exported from the modules used in the service program are exported from the service program. ILE C/400 can define exports as global or static. Only external variables declared in ILE C/400 as global are available with EXPORT(*ALL). In ILE RPG/400, the following are available with EXPORT(*ALL):

- The RPG program name (not to be confused with *PGM object)
- Variables defined with the keyword EXPORT

In ILE COBOL/400, the following language elements are module exports:

- The name in the PROGRAM-ID paragraph in the lexically outermost COBOL program (not to be confused with *PGM object) of a compilation unit. This maps to a strong procedure export.
- The COBOL compiler-generated name derived from the name in the PROGRAM-ID paragraph in the preceding bullet if that program does not have the INITIAL attribute. This maps to a strong procedure export. For information about strong and weak exports, see Export in “Binder Information Listing for Example Service Program” on page A-7.
- Any data item or file item declared as EXTERNAL. This maps to a weak export.

Export Parameter Used with Source File and Source Member Parameters

The default value on the export parameter is *SRCFILE. If *SRCFILE is specified on the export parameter, the binder must also use the SRCFILE and SRCMBR parameters to locate the binder language source.

The following example command binds a service program named UTILITY by using the defaults to locate the binder language source:

```
CRTSRVPGM SRVPGM(*CURLIB/UTILITY)
          MODULE(*SRVPGM)
          EXPORT(*SRCFILE)
          SRCFILE(*LIBL/QSRVSRC)
          SRCMBR(*SRVPGM)
```

For this command to create the service program, a member named UTILITY must be in the source file QSRVSRC. This member must then contain the binder language source that the binder translates into a signature and set of export identifiers. The default is to get the binder language source from a member with the same name as the name of the service program, UTILITY. If a file, member, or binder language source with the values supplied on these parameters is not located, the service program is not created.

Binder Language

The **binder language** is a small set of nonrunnable commands that defines the exports for a service program. The binder language enables the source entry utility (SEU) syntax checker to prompt and validate the input when a BND source type is specified.

The binder language consists of a list of the following commands:

1. Start Program Export (STRPGMEXP) command, which identifies the beginning of a list of exports from a service program
2. Export Symbol (EXPORT) commands, each of which identifies a symbol name available to be exported from a service program
3. End Program Export (ENDPGMEXP) command, which identifies the end of a list of exports from a service program

Figure 4-4 is a sample of the binder language in a source file:

```
STRPGMEXP PGMLVL(*CURRENT) LVLCHK(*YES)
.
.
EXPORT SYMBOL(p1)
EXPORT SYMBOL('p2')
EXPORT SYMBOL('P3')
.
.
ENDPGMEXP
.
.
.
STRPGMEXP PGMLVL(*PRV)
.
.
EXPORT SYMBOL(p1)
EXPORT SYMBOL('p2')
.
.
ENDPGMEXP
```

Figure 4-4. Example of Binder Language in a Source File

A tool is provided in the QUSRTOOL library to help generate the binder language from one or more modules. Member TBNINFO in the file QUSRTOOL/QATTINFO has more information on how to create the tool.

Signature

The symbols identified between a STRPGMEXP PGMLVL(*CURRENT) and ENDPGMEXP pair define the public interface to a service program. That public interface is represented by a **signature**. A signature is a value that identifies the interface supported by a service program.

If you choose not to specify an explicit signature, the binder generates a signature from the list of procedure and data item names to be exported and from the order in which they are specified. Therefore, a signature provides an easy and convenient way to validate the public interface to a service program. A signature does not validate the interface to a particular procedure within a service program.

Start Program Export and End Program Export Commands

The Start Program Export (STRPGMEXP) command identifies the beginning of a list of exports from a service program. The End Program Export (ENDPGMEXP) command identifies the end of a list of exports from a service program.

Multiple STRPGMEXP and ENDPGMEXP pairs specified within a source file cause multiple signatures to be created. The order in which the STRPGMEXP and ENDPGMEXP pairs occur is not significant.

Program Level Parameter on the STRPGMEXP Command

Only one STRPGMEXP command can specify PGMLVL(*CURRENT), but it does not have to be the first STRPGMEXP command. All other STRPGMEXP commands within a source file must specify PGMLVL(*PRV). The current signature represents whichever STRPGMEXP command has PGMLVL(*CURRENT) specified. If more than one of the STRPGMEXP commands is marked *CURRENT, the first one is assumed to be the current one. That command is represented by the current signature.

Level Check Parameter on the STRPGMEXP Command

The level check (LVLCHK) parameter on the STRPGMEXP command specifies whether the binder should automatically check the public interface to a service program. Specifying LVLCHK(*YES), or letting the value default to LVLCHK(*YES), causes the binder to examine the signature parameter. The signature parameter determines whether the binder uses an explicit signature value or generates a nonzero signature value. If the binder generates a signature value, the system verifies that the value matches the value known to the service program's clients. If the values match, clients of the service program can use the public interface without being recompiled.

Specifying LVLCHK(*NO) disables the automatic signature checking. You may decide to use this feature if the following conditions exist:

- You know that certain changes to the interface of a service program do not constitute incompatibilities.
- You want to avoid updating the binder language source file or recompiling clients.

Use the LVLCHK(*NO) value with caution because it means that you are responsible for manually verifying that the public interface is compatible with previous levels. Specify LVLCHK(*NO) only if you can control which procedures of the service program are called and which variables are used by its clients. If you cannot control the public interface, run-time or activation errors may occur. See "Binder Language Errors" on page A-9 for an explanation of the common errors that could occur from using the binder language.

Signature Parameter on the STRPGMEXP Command

The signature (SIGNATURE) parameter allows you to explicitly specify a signature for a service program. The explicit signature can be a hexadecimal string or a character string. You may want to consider explicitly specifying a signature for either of the following reasons:

- The binder could generate a compatible signature that you do not want. A signature is based on the names of the specified exports and on their order. Therefore, if two export blocks have the same exports in the same order, they

have the same signature. As the service program provider, you may know that the two interfaces are not compatible (because, for example, their parameter lists are different). In this case, you can explicitly specify a new signature instead of having the binder generate the compatible signature. If you do so, you create an incompatibility in your service program, forcing some or all clients to recompile.

- The binder could generate an incompatible signature that you do not want. If two export blocks have different exports or a different order, they have different signatures. If, as the service program provider, you know that the two interfaces are really compatible (because, for example, a function name has changed but it is still the same function), you can explicitly specify the same signature as previously generated by the binder instead of having the binder generate an incompatible signature. If you specify the same signature, you maintain a compatibility in your service program, allowing your clients to use your service program without rebinding.

The default value for the signature parameter, *GEN, causes the binder to generate a signature from exported symbols.

You can determine the signature value for a service program by using the Display Service Program (DSPSRVPGM) command and specifying DETAIL(*SIGNATURE).

Export Symbol Command

The Export Symbol (EXPORT) command identifies a symbol name available to be exported from a service program.

If the exported symbols contain lowercase letters, the symbol name should be enclosed within apostrophes as in Figure 4-4 on page 4-11. If apostrophes are not used, the symbol name is converted to all uppercase letters. In the example, the binder searches for an export named P1, not p1.

Binder Language Examples

As an example of using the binder language, assume that you are developing a simple financial application with the following procedures:

- Rate procedure
Calculates an Interest_Rate, given the values of Loan_Amount, Term_of_Payment, and Payment_Amount.
- Amount procedure
Calculates the Loan_Amount, given the values of Interest_Rate, Term_of_Payment, and Payment_Amount.
- Payment procedure
Calculates the Payment_Amount, given the values of Interest_Rate, Term_of_Payment, and Loan_Amount.
- Term procedure
Calculates the Term_of_Payment, given the values of Interest_Rate, Loan_Amount, and Payment_Amount.

Some of the output listings for this application are shown in Appendix A, "Output Listing from CRTPGM, CRTSRVPGM, UPDPGM, or UPDSRVPGM Command" on page A-1.

In the binder language examples, each module contains more than one procedure. This structure is more typical of ILE C/400 than of ILE RPG/400, but the examples apply even to modules that contain only one procedure.

Binder Language Example 1

The binder language for the Rate, Amount, Payment, and Term procedures looks like the following:

```
FILE: MYLIB/QSRVSRC MEMBER: FINANCIAL
```

```
STRPGMEXP PGMLVL(*CURRENT)
  EXPORT SYMBOL('Term')
  EXPORT SYMBOL('Rate')
  EXPORT SYMBOL('Amount')
  EXPORT SYMBOL('Payment')
ENDPGMEXP
```

Some initial design decisions have been made, and three modules (MONEY, RATES, and CALCS) provide the necessary procedures.

To create the service program pictured in Figure 4-5 on page 4-15, the binder language is specified on the following CRTSRVPGM command:

```
CRTSRVPGM SRVPGM(MYLIB/FINANCIAL)
          MODULE(MYLIB/MONEY MYLIB/RATES MYLIB/CALCS)
          EXPORT(*SRCFILE)
          SRCFILE(MYLIB/QSRVSRC)
          SRCMBR(*SRVPGM)
```

Note that source file QSRVSRC in library MYLIB, specified in the SRCFILE parameter, is the file that contains the binder language source.

Also note that no binding directory is needed because all the modules needed to create the service program are specified on the MODULE parameter.

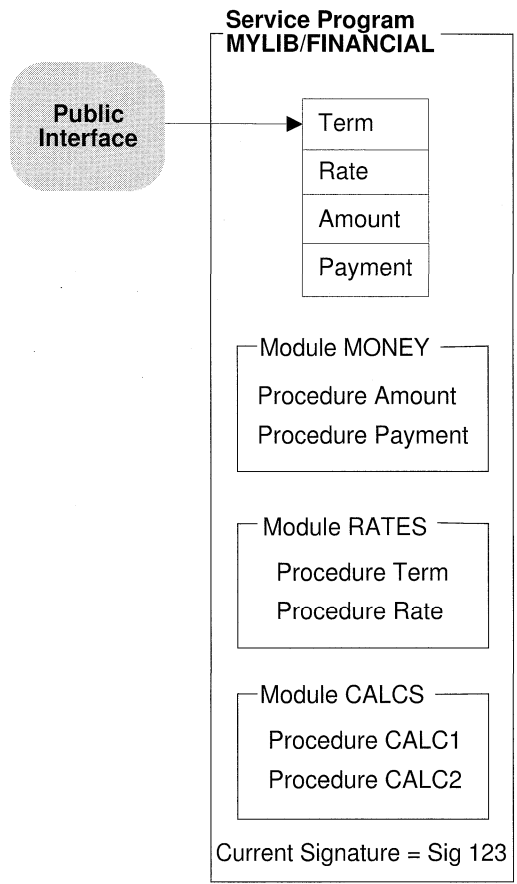

RV2W1051-3

Figure 4-5. Creating a Service Program by Using the Binder Language

Binder Language Example 2

As progress is made in developing the application, a program called **BANKER** is written. **BANKER** needs to use the procedure called **Payment** in the service program called **FINANCIAL**. The resulting application with the **BANKER** program is shown in Figure 4-6 on page 4-16.

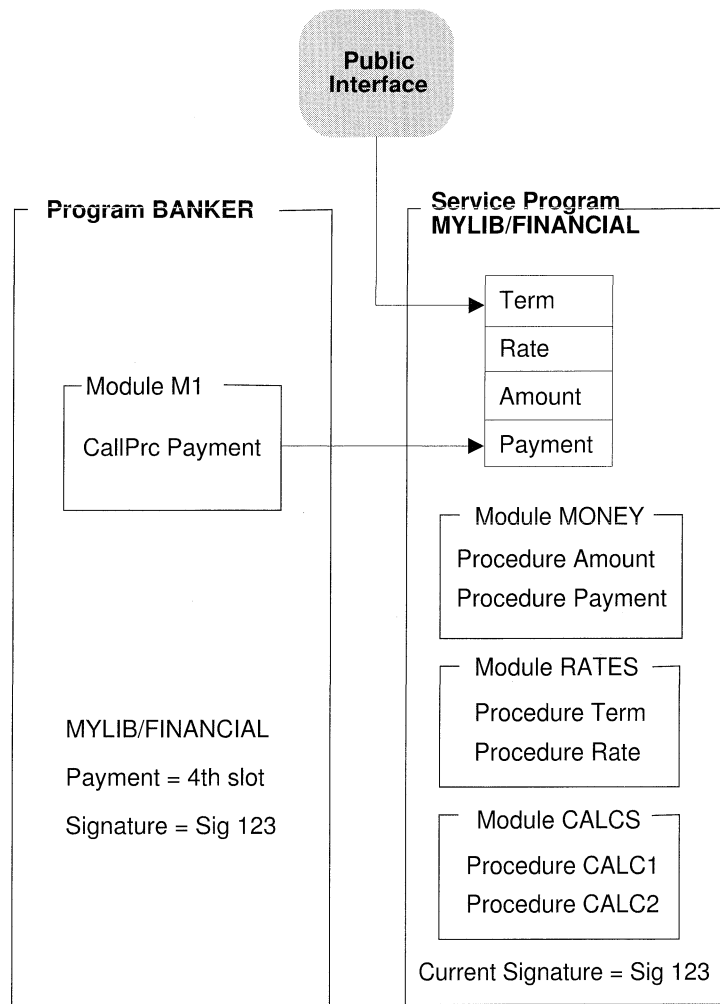

RV2W1053-4

Figure 4-6. Using the Service Program FINANCIAL

When the BANKER program was created, the MYLIB/FINANCIAL service program was provided on the BNDSRVPGM parameter. The symbol Payment was found to be exported from the fourth slot of the public interface of the FINANCIAL service program. The current signature of MYLIB/FINANCIAL along with the slot associated with the Payment interface is saved with the BANKER program.

During the process of getting BANKER ready to run, activation verifies the following:

- Service program FINANCIAL in library MYLIB can be found.
- The service program still supports the signature (SIG 123) saved in BANKER.

This signature checking verifies that the public interface used by BANKER when it was created is still valid at run time.

As shown in Figure 4-6, at the time BANKER gets called, MYLIB/FINANCIAL still supports the public interface used by BANKER. If activation cannot find either a matching signature in MYLIB/FINANCIAL or the service program MYLIB/FINANCIAL, the following occurs:

BANKER fails to get activated.
An error message is issued.

Binder Language Example 3

As the application continues to grow, two new procedures are needed to complete our financial package. The two new procedures, OpenAccount and CloseAccount, open and close the accounts, respectively. The following steps need to be performed to update MYLIB/FINANCIAL such that the program BANKER does not need to be re-created:

1. Write the procedures OpenAccount and CloseAccount.
2. Update the binder language to specify the new procedures.

The updated binder language supports the new procedures. It also allows the existing ILE programs or service programs that use the FINANCIAL service program to remain unchanged. The binder language looks like this:

```
FILE: MYLIB/QSRVSRC MEMBER: FINANCIAL
```

```
STRPGMEXP PGMLVL(*CURRENT)
  EXPORT SYMBOL('Term')
  EXPORT SYMBOL('Rate')
  EXPORT SYMBOL('Amount')
  EXPORT SYMBOL('Payment')
  EXPORT SYMBOL('OpenAccount')
  EXPORT SYMBOL('CloseAccount')
ENDPGMEXP
```

```
STRPGMEXP PGMLVL(*PRV)
  EXPORT SYMBOL('Term')
  EXPORT SYMBOL('Rate')
  EXPORT SYMBOL('Amount')
  EXPORT SYMBOL('Payment')
ENDPGMEXP
```

When an update operation to a service program is needed to do both of the following:

- Support new procedures or data items
- Allow the existing programs and service programs that use the changed service program to remain unchanged

one of two alternatives must be chosen. The first alternative is to perform the following steps:

1. Duplicate the STRPGMEXP, ENDPGMEXP block that contains PGMLVL(*CURRENT).
2. Change the duplicated PGMLVL(*CURRENT) value to PGMLVL(*PRV).
3. In the STRPGMEXP command that contains PGMLVL(*CURRENT), add to the end of the list the new procedures or data items to be exported.
4. Save the changes to the source file.
5. Create or re-create the new or changed modules.
6. Create the service program from the new or changed modules by using the updated binder language.

The second alternative is to take advantage of the signature parameter on the STRPGMEXP command and to add new symbols at the end of the export block:

```

STRPGMEXP PGMVAL(*CURRENT) SIGNATURE('123')
EXPORT SYMBOL('Term')
.
.
EXPORT SYMBOL('OpenAccount')
EXPORT SYMBOL('CloseAccount')
ENDPGMEXP

```

To create the enhanced service program shown in Figure 4-7, the updated binder language specified on page 4-17 is used on the following CRTSRVPGM command:

```

CRTSRVPGM SRVPGM(MYLIB/FINANCIAL)
MODULE(MYLIB/MONEY MYLIB/RATES MYLIB/CALCS MYLIB/ACCOUNTS))
EXPORT(*SRCFILE)
SRCFILE(MYLIB/QSRVSRC)
SRCMBR(*SRVPGM)

```

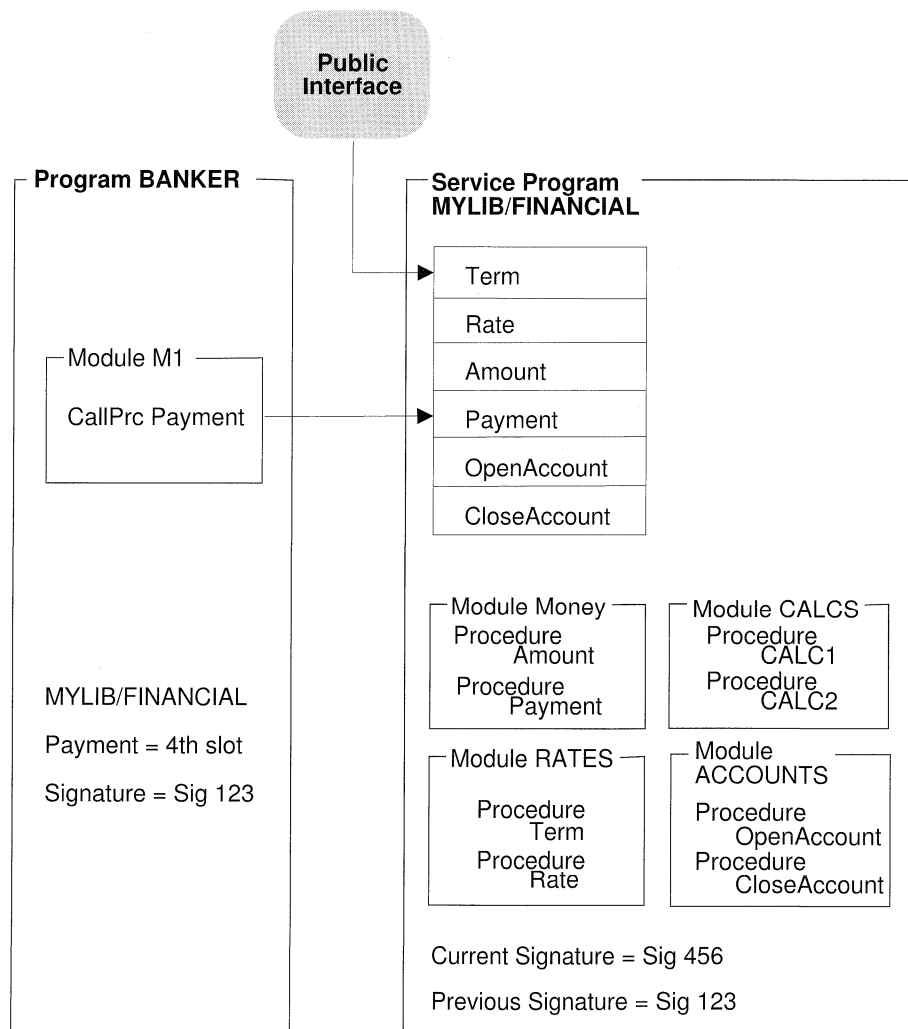

RV2W1052-4

Figure 4-7. Updating a Service Program by Using the Binder Language

The BANKER program does not have to change because the previous signature is still supported. (See the previous signature in the service program MYLIB/FINANCIAL and the signature saved in BANKER.) If BANKER were re-

created by the CRTPGM command, the signature that is saved with BANKER would be the current signature of service program FINANCIAL. The only reason to re-create the program BANKER is if the program used one of the new procedures provided by the service program FINANCIAL. The binder language allows you to enhance the service program without changing the programs or service programs that use the changed service program.

Binder Language Example 4

After shipping the updated FINANCIAL service program, you receive a request to create an interest rate based on the following:

The current parameters of the Rate procedure
The credit history of the applicant

A fifth parameter, called Credit_History, must be added on the call to the Rate procedure. Credit_History updates the Interest_Rate parameter that gets returned from the Rate procedure. Another requirement is that existing ILE programs or service programs that use the FINANCIAL service program must not have to be changed. If the language does not support passing a variable number of parameters, it seems difficult to do both of the following:

- Update the service program
- Avoid re-creating all the other objects that use the FINANCIAL service program

Fortunately, however, there is a way to do this. The following binder language supports the updated Rate procedure. It still allows existing ILE programs or service programs that use the FINANCIAL service program to remain unchanged.

FILE: MYLIB/QSRVSRC MEMBER: FINANCIAL

```
STRPGMEXP PGMLVL(*CURRENT)
  EXPORT SYMBOL('Term')
  EXPORT SYMBOL('Old_Rate') /* Original Rate procedure with four parameters */
  EXPORT SYMBOL('Amount')
  EXPORT SYMBOL('Payment')
  EXPORT SYMBOL('OpenAccount')
  EXPORT SYMBOL('CloseAccount')
  EXPORT SYMBOL('Rate') /* New Rate procedure that supports +
                          a fifth parameter, Credit_History */
ENDPGMEXP

STRPGMEXP PGMLVL(*PRV)
  EXPORT SYMBOL('Term')
  EXPORT SYMBOL('Rate')
  EXPORT SYMBOL('Amount')
  EXPORT SYMBOL('Payment')
  EXPORT SYMBOL('OpenAccount')
  EXPORT SYMBOL('CloseAccount')
ENDPGMEXP

STRPGMEXP PGMLVL(*PRV)
  EXPORT SYMBOL('Term')
  EXPORT SYMBOL('Rate')
  EXPORT SYMBOL('Amount')
  EXPORT SYMBOL('Payment')
ENDPGMEXP
```

The original symbol `Rate` was renamed `Old_Rate` but remains in the same relative position of symbols to be exported. This is important to remember.

A comment is associated with the `Old_Rate` symbol. A comment is everything between `/*` and `*/`. The binder ignores comments in the binder language source when creating a service program.

The new procedure `Rate`, which supports the additional parameter of `Credit_History`, must also be exported. This updated procedure is added to the end of the list of exports.

The following two ways can deal with the original `Rate` procedure:

- Rename the original `Rate` procedure that supports four parameters as `Old_Rate`. Duplicate the `Old_Rate` procedure (calling it `Rate`). Update the code to support the fifth parameter of `Credit_History`.
- Update the original `Rate` procedure to support the fifth parameter of `Credit_History`. Create a new procedure called `Old_Rate`. `Old_Rate` supports the original four parameters of `Rate`. It also calls the new updated `Rate` procedure with a dummy fifth parameter.

This is the preferred method because maintenance is simpler and the size of the object is smaller.

Using the updated binder language and a new `RATES` module that supports the procedures `Rate`, `Term`, and `Old_Rate`, you create the following `FINANCIAL` service program:

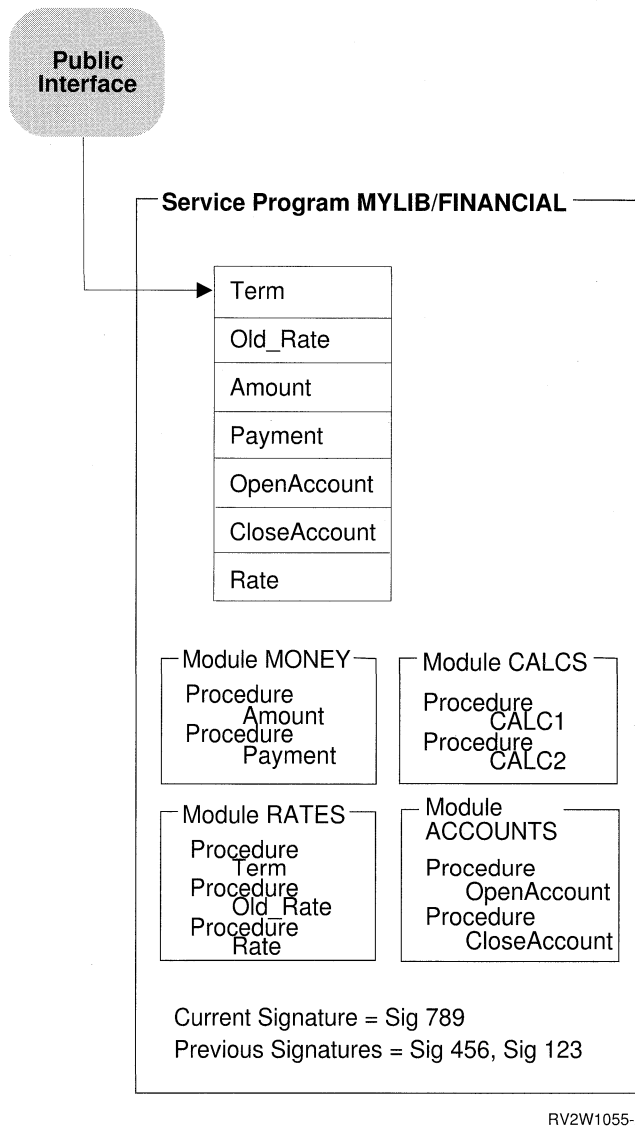

Figure 4-8. Updating a Service Program by Using the Binder Language

The ILE programs and service programs that use the original Rate procedure of the FINANCIAL service program go to slot 2. This directs the call to the Old_Rate procedure, which is advantageous because Old_Rate handles the original four parameters. If any of the ILE programs or service programs that used the original Rate procedure need to be re-created, do one of the following:

- To continue to use the original four-parameter Rate procedure, call the Old_Rate procedure instead of the Rate procedure.
- To use the new Rate procedure, add the fifth parameter, Credit_History, to each call to the Rate procedure.

When an update to a service program must meet the following requirements:

- Support a procedure that changed the number of parameters it can process
- Allow existing programs and service programs that use the changed service program to remain unchanged

the following steps need to be performed:

1. Duplicate the STRPGMEXP, ENDPGMEXP block that contains PGMLVL(*CURRENT).
2. Change the duplicated PGMLVL(*CURRENT) value to PGMLVL(*PRV).
3. In the STRPGMEXP command that contains PGMLVL(*CURRENT), rename the original procedure name, but leave it in the same relative position.

In this example, Rate was changed to Old_Rate but left in the same relative position in the list of symbols to be exported.
4. In the STRPGMEXP command that has PGMLVL(*CURRENT), place the original procedure name at the end of the list that supports a different number of parameters.

In this example, Rate is added to the end of the list of exported symbols, but this Rate procedure supports the additional parameter Credit_History.
5. Save the changes to the binder language source file.
6. In the file containing the source code, enhance the original procedure to support the new parameter.

In the example, this means changing the existing Rate procedure to support the fifth parameter of Credit_History.
7. A new procedure is created that handles the original parameters as input and calls the new procedure with a dummy extra parameter.

In the example, this means adding the Old_Rate procedure that handles the original parameters and calling the new Rate procedure with a dummy fifth parameter.
8. Save the binder language source code changes.
9. Create the module objects with the new and changed procedures.
10. Create the service program from the new and changed modules using the updated binder language.

Program Updates

After an ILE program object or service program is created, you may have to correct an error in it or add an enhancement to it. However, after you service the object, it may be so large that shipping the entire object to your customers is difficult or expensive.

You can reduce the shipment size by using the Update Program (UPDPGM) or Update Service Program (UPDSRVPGM) command. These commands replace only the specified modules, and only the changed or added modules have to be shipped to your customers.

For example, Figure 4-9 on page 4-23 shows module MONEY being replaced in service program MYLIB/FINANCIAL:

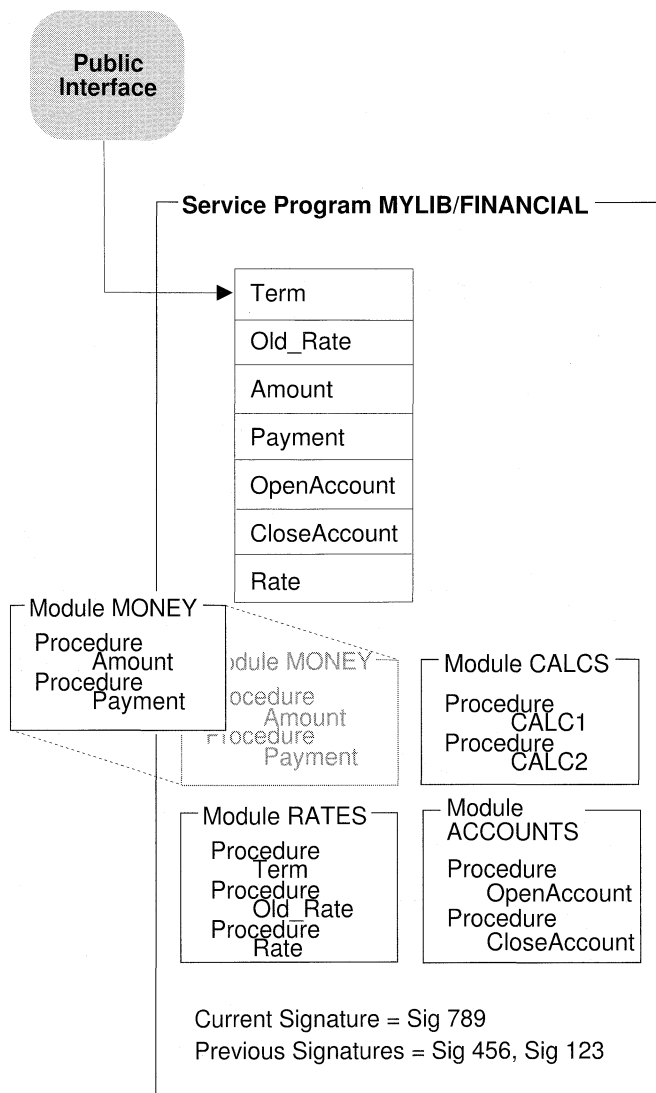

RV3W105-0

Figure 4-9. Replacing a Module in a Service Program

Occasionally, the same module is bound into multiple program objects or service programs. If you use the PTF process, an exit program containing one or more calls to the UPDPGM or UPDSRVPGM command may complete the service package.

The allow update (ALWUPD) parameter on the CRTPGM or CRTSRVPGM command determines whether a program object or service program can be updated. If ALWUPD(*NO) is specified, the modules in a program object or service program cannot be replaced by the UPDPGM or UPDSRVPGM command.

Important Parameters on the UPDPGM and UPDSRVPGM Commands

Each module specified on the module parameter replaces a module with the same name that is bound into a program object or service program. If more than one module bound into a program object or service program has the same name, the replacement library (RPLLIB) parameter is used. This parameter specifies which method is used to select the module to be replaced. If no module with the same

name is already bound into a program object or service program, the program object or service program is not updated.

The bound service program (BNDSRVPGM) parameter specifies additional service programs beyond those that the program object or service program is already bound to. If a replacing module contains more imports or fewer exports than the module it replaces, these service programs may be needed to resolve those imports.

The binding directory (BNDDIR) parameter specifies binding directories that contain modules or service programs that also may be required to resolve extra imports.

Module Replaced by a Module with Fewer Imports

If a module is replaced by another module with fewer imports, the new program object or service program is always created. However, the updated program object or service program contains an isolated module if the following conditions exist:

- Because of the now missing imports, one of the modules bound into a program object or service program no longer resolves any imports
- That module originally came from a binding directory used on the CRTPGM or CRTSRVPGM command

Programs with isolated modules may grow significantly over time. To remove modules that no longer resolve any imports and that originally came from a binding directory, you can specify OPTION(*TRIM) when updating the objects. However, if you use this option, the exports that the modules contain are not available for future program updates.

Module Replaced by a Module with More Imports

If a module is replaced by a module with more imports, the program object or service program can be updated if those extra imports are resolved, given the following:

- The existing set of modules bound into the object.
- Service programs bound to the object.
- Binding directories specified on the command. If a module in one of these binding directories contains a required export, the module is added to the program or service program. If a service program in one of these binding directories contains a required export, the service program is bound by reference to the program or service program.
- Implicit binding directories. An **implicit binding directory** is a binding directory that contains exports that may be needed to create a program that contains the module. Every ILE compiler builds a list of implicit binding directories into each module it creates.

If those extra imports cannot be resolved, the update operation fails unless OPTION(*UNRSLVREF) is specified on the update command.

Module Replaced by a Module with Fewer Exports

If a module is replaced by another module with fewer exports, the update occurs if the following conditions exist:

- The missing exports are not needed for binding.

- The missing exports are not exported out of the service program in the case of UPDSRVPGM. The service program export is different if EXPORT(*ALL) is specified.

The update does not occur if the following conditions exist:

- Some imports cannot be resolved because of the missing exports.
- Those missing exports cannot be found from the extra service programs and binding directories specified on the command.
- The binder language indicates to export a symbol, but the export is missing.

Module Replaced by a Module with More Exports

If a module is replaced by another module with more exports, the update operation occurs if all the extra exports are uniquely named. The service program export is different if EXPORT(*ALL) is specified.

However, if one or more of the extra exports are not uniquely named, the duplicate names may cause a problem:

- If OPTION(*NODUPPROC) or OPTION(*NODUPVAR) is specified on the update command, the program object or service program is not updated.
- If OPTION(*DUPPROC) or OPTION(*DUPVAR) is specified, the update occurs, but the export with the duplicate name selected for binding may be different. If the module being replaced was specified on the CRTPGM or CRTSRVPGM command before the object that contains the selected export, the selected export is selected. (If the data item is weak, it still may not be selected.)

Tips for Creating Modules, Programs, and Service Programs

To create and maintain modules, ILE programs, and service programs conveniently, consider the following:

- Follow a naming convention for the modules that will get copied to create a program or service program.

A naming strategy with a common prefix makes it easier to specify modules generically on the module parameter.

- For ease of maintenance, include each module in only one program or service program. If more than one program needs to use a module, put the module in a service program. That way, if you have to redesign a module, you only have to redesign it in one place.
- To ensure your signature, use the binder language whenever you create a service program.

The binder language allows the service program to be easily updated without having to re-create the using programs and service programs.

A tool in QUSRTOOL helps generate the binder language from a set of specified modules. This tool can be used to prime the source file with the existing exported procedure and data item names in a module. With a little editing, the source file can be updated to contain the binder language to describe the public interface to the service program. The tool is described in member TBNINFO of the QUSRTOOL/QATTINFO file.

If either of the following conditions exists:

- A service program will never change
- Users of the service program do not mind changing their programs when a signature changes

you do not need to use the binder language. Because this situation is not likely for most applications, consider using the binder language for all service programs.

- If other people will use a program object or service program that you create, specify `OPTION(*RSLVREF)` when you create it. When you are developing an application, you may want to create a program object or service program with unresolved imports. However, when in production, all the imports should be resolved.

If `OPTION(*WARN)` is specified, unresolved references are listed in the job log that contains the `CRTPGM` or `CRTSRVPGM` request. If you specify a listing on the `DETAIL` parameter, they are also included on the program listing. You should keep the job log or listing.

- When designing new applications, determine if common procedures that should go into one or more service programs can be identified.

It is probably easiest to identify and design common procedures for new applications. If you are converting an existing application to use ILE, it may be more difficult to determine common procedures for a service program. Nevertheless, try to identify common procedures needed by the application and try to create service programs containing the common procedures.

- When converting an existing application to ILE, consider creating a few large programs.

With a few, usually minor changes, you can easily convert an existing application to take advantage of the ILE capabilities. After you create the modules, combining them into a few large programs may be the easiest and least expensive way to convert to ILE.

Using a few large programs rather than many small programs has the additional advantage of using less storage.

- Try to limit the number of service programs your application uses.

This may require a service program to be created from more than one module. The advantages are a faster activation time and a faster binding process.

There are very few right answers for the number of service programs an application should use. If a program uses hundreds of service programs, it is probably using too many. On the other hand, one service program may not be practical either.

As an example, approximately 10 service programs are provided for the language-specific and common run-time routines provided by the OS/400. Over 70 modules went into creating these 10 service programs. This ratio seems to be a good balance for performance, understandability, and maintainability.

Chapter 5. Activation Group Management

This chapter contains examples of how to structure an application using activation groups. Topics include:

- Supporting multiple applications
- Using the Reclaim Resources (RCLRSC) command with OPM and ILE programs
- Deleting activation groups with the Reclaim Activation Group (RCLACTGRP) command
- Service programs and activation groups

Multiple Applications Running in the Same Job

User-named activation groups allow you to leave an activation group in a job for later use. A normal return operation or a skip operation (such as `longjmp()` in ILE C/400) past the control boundary does not delete your activation group.

This allows you to leave your application in its last-used state. Static variables and open files remain unchanged between calls into your application. This can save processing time and may be necessary to implement the function you are trying to provide.

You should be prepared, however, to accept requests from multiple independent clients running in the same job. The system does not limit the number of ILE programs that can be bound to your ILE service program. As a result, you may need to support multiple clients.

Figure 5-1 on page 5-2 shows a technique that you may use to share common service functions while keeping the performance advantages of a user-named activation group.

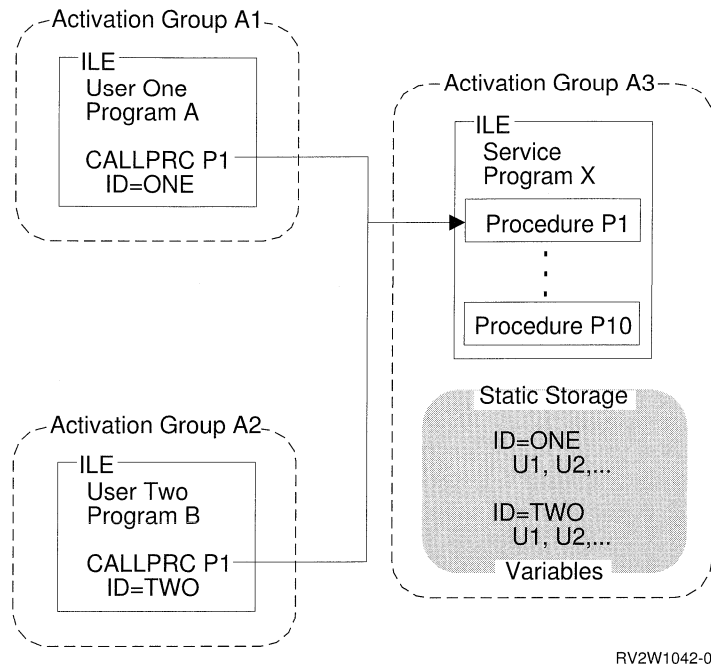

RV2W1042-0

Figure 5-1. Multiple Applications Running in the Same Job

Each call to a procedure in service program X requires a user handle. The field ID represents a user handle in this example. Each user is responsible for providing this handle. An initialization routine to return a unique handle for each user is implemented by you.

When a call is made to your service program, the user handle is used to locate the storage variables that relate to this user. While saving activation-group creation time, you can support multiple clients at the same time.

Reclaim Resources Command

The Reclaim Resources (RCLRSC) command depends on a system concept known as a **level number**. A level number is a unique value assigned by the system to certain resources you use within a job. Three level numbers are defined as follows:

Call level number

Each call stack entry is given a unique level number

Program-activation level number

Each OPM and ILE program activation is given a unique level number

Activation-group level number

Each activation group is given a unique level number

As your job runs, the system continues to assign unique level numbers for each new occurrence of the resources just described. The level numbers are assigned in increasing value. Resources with higher level numbers are created after resources with lower level numbers.

Figure 5-2 on page 5-3 shows an example of using the RCLRSC command on OPM and ILE programs. Call-level scoping has been used for the open files shown in this example. When call-level scoping is used, each data management resource is given the same level numbers as the call stack entry that created that resource.

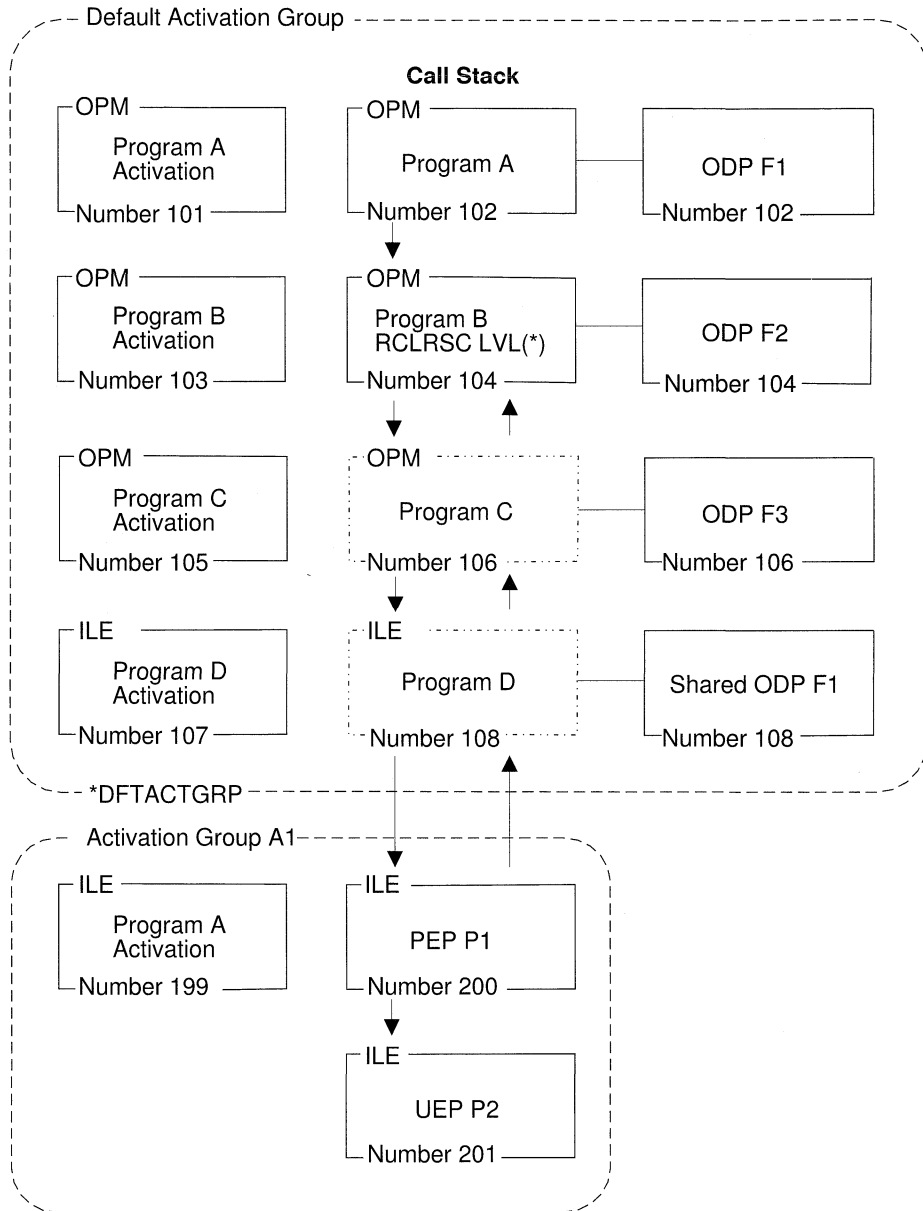

RV3W100-0

Figure 5-2. Reclaim Resources

In this example, the calling sequence is programs A, B, C, and D. Programs D and C return to program B. Program B is about to use the RCLRSC command with an option of LVL(*). The RCLRSC command uses the level (LVL) parameter to clean up resources. All resources with a call-level number greater than the call-level number of the current call stack entry are cleaned up. In this example, call-level number 104 is used as the starting point. All resources greater than call-level number 104 are deleted. Note that resources in call level 200 and 201 are unaffected by RCLRSC because they are in an ILE activation group. RCLRSC works only in the default activation group.

In addition, the storage from programs C and D and the open data path (ODP) for file F3 is closed. File F1 is shared with the ODP opened in program A. The shared ODP is closed, but file F1 remains open.

Reclaim Resources Command for OPM Programs

The Reclaim Resources (RCLRSC) command may be used to close open files and free static storage for OPM programs that have returned without ending. Some OPM languages, such as RPG, allow you to return without ending the program. If you later want to close the program's files and free its storage, you may use the RCLRSC command.

Reclaim Resources Command for ILE Programs

For ILE programs that are created by the CRTBNDxxx command with DFTACTGRP(*YES) specified, the RCLRSC command frees static storage just as it does for OPM programs. For ILE programs that are **not** created by the CRTBNDxxx command with DFTACTGRP(*YES) specified, the RCLRSC command reinitializes any activations that have been created in the default activation group but does not free static storage. ILE programs that use large amounts of static storage should be activated in an ILE activation group. Deleting the activation group returns this storage to the system. The RCLRSC command closes files opened by service programs or ILE programs running in the default activation group. The RCLRSC command does not reinitialize static storage of service programs and does not affect nondefault activation groups.

To use the RCLRSC command directly from ILE, you can use either the QCAPCMD API or an ILE CL procedure. The QCAPCMD API allows you to directly call system commands without the use of a CL program. In Figure 5-2 on page 5-3, directly calling system commands is important because you may want to use the call-level number of a particular ILE procedure. Certain languages, such as ILE C/400, also provide a system function that allows direct running of OS/400 commands.

Reclaim Activation Group Command

The Reclaim Activation Group (RCLACTGRP) command can be used to delete a nondefault activation group that is not in use. This command allows options to either delete all eligible activation groups or to delete an activation group by name.

Service Programs and Activation Groups

When you create an ILE service program, decide whether to specify an option of *CALLER or a name for the ACTGRP parameter. This option determines whether your service program will be activated into the caller's activation group or into a separately named activation group. Either choice has advantages and disadvantages. This topic discusses what each option provides.

For the ACTGRP(*CALLER) option, the service program functions as follows:

- Static procedure calls are fast
Static procedure calls into the service program are optimized when running in the same activation group.
- Shared external data
Service programs may export data to be used by other programs and service programs in the same activation group.
- Shared data management resources

Open files and other data management resources may be shared between the service program and other programs in the activation group. The service program may issue a commit operation or a rollback operation that affects the other programs in the activation group.

- No control boundary

Unhandled exceptions within the service program percolate to the client programs. HLL end verbs used within the service program can delete the activation group of the client programs.

For the ACTGRP(name) option, the service program functions as follows:

- Separate address space for variables

The client program cannot manipulate pointers to address your working storage. This may be important if your service program is running with adopted authority.

- Separate data management resources

You have your own open files and commitment definitions. The accidental sharing of open files is prevented.

- State information controlled

You control when the application storage is deleted. By using HLL end verbs or normal language return statements, you can decide when to delete the application. You must, however, manage the state information for multiple clients.

Chapter 6. Calls to Procedures and Programs

The ILE call stack and argument-passing methods facilitate interlanguage communication, making it easier for you to write mixed-language applications. This chapter discusses different examples of dynamic program calls and static procedure calls, which were introduced in “Calls to Programs and Procedures” on page 2-10. A third type of call, the procedure pointer call, is introduced.

In addition, this chapter discusses original program model (OPM) support for OPM and ILE application programming interfaces (APIs).

Call Stack

The **call stack** is a last-in-first-out (LIFO) list of **call stack entries**, one entry for each called procedure or program. Each call stack entry has information about the automatic variables for the procedure and about other resources scoped to the call stack entry, such as condition handlers and cancel handlers.

There is one call stack per job. A call adds a new entry on the call stack for the called procedure or program and passes control to the called object. A return removes the stack entry and passes control back to the calling procedure or program in the previous stack entry.

Call Stack Example

Figure 6-1 on page 6-2 contains a segment of a call stack with two programs: an OPM program (Program A) and an ILE program (Program B). Program B contains three procedures: its program entry procedure, its user entry procedure, and another procedure (P1). The concepts of program entry procedure (PEP) and user entry procedure (UEP) are defined in “Module Object” on page 2-2. The call flow includes the following steps:

1. A dynamic program call to Program A.
2. Program A calls Program B, passing control to its PEP. This call to Program B is a dynamic program call.
3. The PEP calls the UEP. This is a static procedure call.
4. The UEP calls procedure P1. This is a static procedure call.

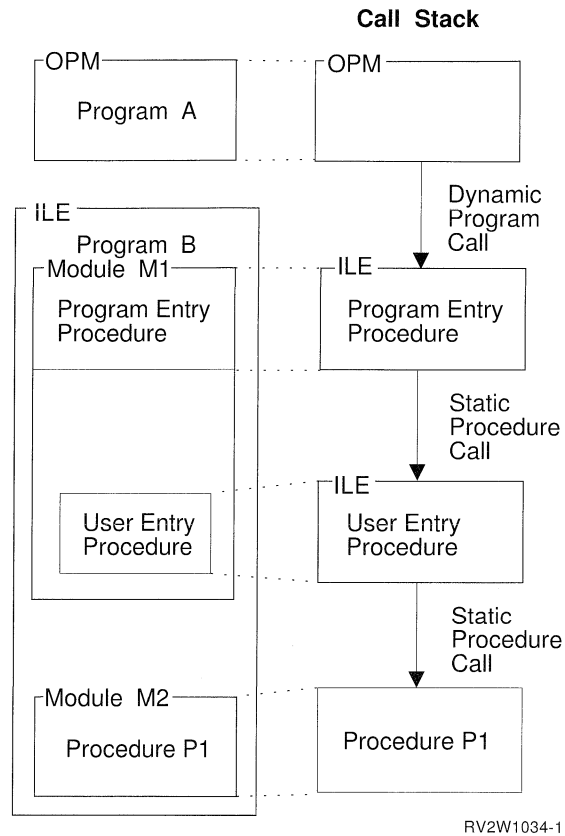

Figure 6-1. Dynamic Program Calls and Static Procedure Calls on the Call Stack

Figure 6-1 illustrates the call stack for this example. The most recently called entry on the stack is depicted at the bottom of the stack. It is the entry that is currently processing. The current call stack entry may do either of the following:

- Call another procedure or program, which adds another entry to the bottom of the stack.
- Return control to its caller after it is done processing, which removes itself from the stack.

Assume that, after procedure P1 is done, no more processing is needed from Program B. Procedure P1 returns control to the UEP, and P1 is removed from the stack. Then the UEP returns control to the PEP, and the UEP is removed from the stack. Finally, the PEP returns control to Program A, and the PEP is removed from the stack. Only Program A is left on this segment of the call stack. Program A continues processing from the point where it made the dynamic program call to Program B.

Calls to Programs and Calls to Procedures

Three types of calls can be made during ILE run time: dynamic program calls, static procedure calls, and procedure pointer calls.

When an ILE program is activated, all of its procedures except its PEP become available for static procedure calls and procedure pointer calls. Program activation occurs when the program is called by a dynamic program call, and all ILE service programs that are bound to the called program are also activated. The procedures

in an ILE service program can be accessed only by static procedure calls or by procedure pointer calls (not by dynamic program calls).

Static Procedure Calls

A call to an ILE procedure adds a new call stack entry to the bottom of the stack and passes control to a specified procedure. Examples include any of the following:

1. A call to a procedure in the same module
2. A call to a procedure in a different module in the same ILE program or service program
3. A call to a procedure that has been exported from an ILE service program in the same activation group
4. A call to a procedure that has been exported from an ILE service program in a different activation group

In examples 1, 2, and 3, the static procedure call does not cross an activation group boundary. The call path length, which affects performance, is identical. This call path is much shorter than the path for a dynamic program call to an ILE or OPM program. In example 4, the call crosses an activation group boundary, and additional processing is done to switch activation group resources. The call path length is longer than the path length of a static procedure call within an activation group, but still shorter than for a dynamic program call.

For a static procedure call, the called procedure must be bound to the calling procedure during binding. The call always accesses the same procedure. This contrasts with a call to a procedure through a pointer, where the target of the call can vary with each call.

Procedure Pointer Calls

Procedure pointer calls provide a way to call a procedure dynamically. For example, by manipulating arrays, or tables, of procedure names or addresses, you can dynamically route a procedure call to different procedures.

Procedure pointer calls add entries to the call stack in exactly the same manner as static procedure calls. Any procedure that can be called using a static procedure call can also be called through a procedure pointer. If the called procedure is in the same activation group, the cost of a procedure pointer call is almost identical to the cost of a static procedure call. Procedure pointer calls can additionally access procedures in any ILE program that has been activated.

Passing Arguments to ILE Procedures

In an ILE procedure call, an **argument** is an expression that represents a value that the calling procedure passes to the procedure specified in the call. ILE languages use three methods for passing arguments:

- | | |
|-----------------------------|---|
| by value, directly | The value of the data object is placed directly into the argument list. |
| by value, indirectly | The value of the data object is copied to a temporary location. The address of the copy (a pointer) is placed into the argument list. |

by reference A pointer to the data object is placed into the argument list. Changes made by the called procedure to the argument are reflected in the calling procedure.

Figure 6-2 illustrates these argument passing styles. Not all ILE languages support passing by value, directly. The available passing styles are described in the ILE HLL programmer's guides.

By value, directly

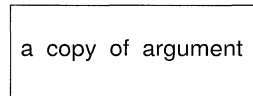

By value, indirectly



By reference

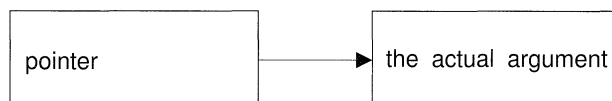

RV2W1027-1

Figure 6-2. Methods for Passing Arguments to ILE Procedures

HLL semantics usually determine when data is passed by value and when it is passed by reference. For example, ILE C/400 passes and accepts arguments by value, directly, while for ILE COBOL/400 and ILE RPG/400, arguments are usually passed by reference. You must ensure that the calling program or procedure passes arguments in the manner expected by the called procedure. The ILE HLL programmer's guides contain more information on passing arguments to different languages.

A maximum of 400 arguments are allowed on a static procedure call. Each ILE language may further restrict the maximum number of arguments. The ILE languages support the following argument-passing styles:

- ILE C/400 passes and accepts arguments by value directly, widening integers, and floating-point values. Arguments can also be passed by value indirectly by specifying the #pragma argument directive for a called function.
- ILE COBOL/400 passes arguments by reference or by value indirectly. ILE COBOL/400 accepts parameters only indirectly.
- ILE RPG/400 passes and accepts arguments by reference.
- ILE CL passes and accepts arguments by reference.

Function Results

To support HLLs that allow the definition of functions (procedures that return a result argument), the model assumes that a special function result argument may be present, as shown in Figure 6-3 on page 6-5. As described in the ILE HLL programmer's guides, some ILE languages use a common mechanism for returning function results.

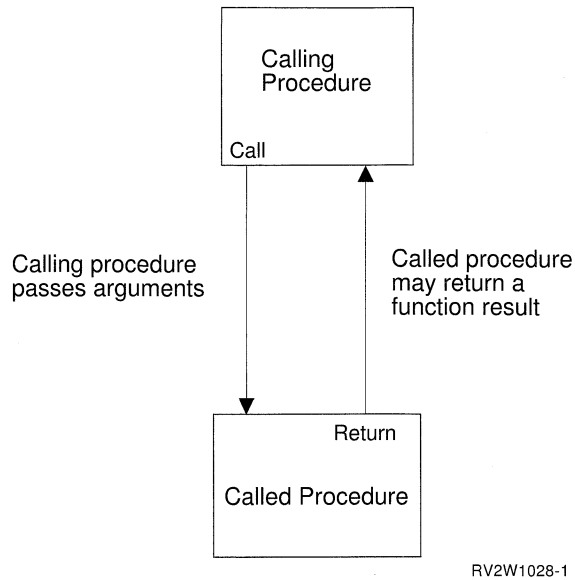

Figure 6-3. Program Call Argument Terminology

Omitted Arguments

All ILE languages can simulate omitted arguments, which allows the use of the feedback code mechanism for ILE condition handlers and other run-time procedures. For example, if an ILE C/400 procedure or an ILE bindable API is expecting an argument passed by reference, you can sometimes omit the argument by passing a null pointer in its place. For information about how to specify an omitted argument in a specific ILE language, refer to the programmer's guide for that language. The *System API Reference* specifies which arguments can be omitted for each API.

For ILE languages that do not provide an intrinsic way for a called procedure to test if an argument has been omitted, the Test for Omitted Argument (CEETSTA) bindable API is available.

Dynamic Program Calls

A dynamic program call is a call made to a program object. For example, when you use the CL command CALL, you are making a dynamic program call.

OPM programs are called by using dynamic program calls. OPM programs are additionally limited to making only dynamic program calls.

EPM programs can make program calls and procedure calls. EPM programs can also be called by other programs and procedures.

ILE programs are also called by dynamic program calls. The procedures within an activated ILE program can be accessed by using static procedure calls or procedure pointer calls. ILE programs that have not been activated yet must be called by a dynamic program call.

In contrast to static procedure calls, which are bound at compile time, symbols for dynamic program calls are resolved to addresses when the call is performed. As a result, a dynamic program call uses more system resources than a static procedure call. Examples of a dynamic program call include:

- A call to an ILE program, an EPM program, or an OPM program
- A call to a non-bindable API

A dynamic program call to an ILE program passes control to the PEP of the identified program, which then passes control to the UEP of the program. After the called program is done processing, control is passed back to the instruction following the call program instruction.

Passing Arguments on a Dynamic Program Call

Calls to ILE or OPM programs (in contrast to calls to ILE procedures) usually pass arguments by reference, meaning that the called program receives the address of the arguments. EPM programs can receive arguments passed by reference, by value directly, or by value indirectly.

When using a dynamic program call, you need to know the method of argument passing that is expected by the called program and how to simulate it if necessary. A maximum of 255 arguments are allowed on a dynamic program call. Each ILE language may further restrict the maximum number of arguments. Information on how to use the different passing methods is contained in the ILE HLL programmer's guides, and, for passing methods in EPM, in the *Pascal User's Guide*.

Interlanguage Data Compatibility

ILE calls allow arguments to be passed between procedures that are written in different HLLs. To facilitate data sharing between the HLLs, some ILE languages have added data types. For example, ILE COBOL/400 added USAGE PROCEDURE-POINTER as a new data type.

To pass arguments between HLLs, you need to know the format each HLL expects of arguments it is receiving. The calling procedure is required to make sure the arguments are the size and type expected by the called procedure. For example, an ILE C/400 function may expect a 4-byte integer, even if a short integer (2 bytes) is declared in the parameter list. Information on how to match data type requirements for passing arguments is contained in the ILE HLL programmer's guides.

Syntax for Passing Arguments in Mixed-Language Applications

Some ILE languages provide syntax for passing arguments to procedures in other ILE languages. For example, ILE C/400 provides a `#pragma` argument to pass value arguments to other ILE procedures by value indirectly.

Operational Descriptors

Operational descriptors may be useful to you if you are writing a procedure or API that can receive arguments from procedures written in different HLLs. **Operational descriptors** provide descriptive information to the called procedure in cases where the called procedure cannot precisely anticipate the form of the argument (for example, different types of strings). The additional information allows the procedure to properly interpret the arguments.

The argument supplies the value; the operational descriptor supplies information about the argument's size, shape and type. For example, this information may include the length of a character string and the type of string.

With operational descriptors, services such as bindable APIs are not required to have a variety of different bindings for each HLL, and HLLs do not have to imitate incompatible data types. A few ILE bindable APIs use operational descriptors to accommodate the lack of common string data types between HLLs. The presence of the operational descriptor is transparent to the API user.

Operational descriptors support HLL semantics while being invisible to procedures that do not use or expect them. Each ILE language can use data types that are appropriate to the language. Each ILE language compiler provides at least one method for generating operational descriptors. For more information on HLL semantics for operational descriptors, refer to the ILE HLL reference manual.

Operational descriptors are distinct from other data descriptors with which you may be familiar. For instance, they are unrelated to the descriptors associated with distributed data or files.

Requirements of Operational Descriptors

You should use operational descriptors when they are expected by a called procedure written in a different ILE language and when they are expected by an ILE bindable API. Generally, bindable APIs require descriptors for most string arguments. Information on bindable APIs in the *System API Reference* specifies whether a given bindable API requires operational descriptors.

Absence of a Required Descriptor

The omission of a required descriptor is an error. If a procedure requires a descriptor for a specific parameter, this requirement forms part of the interface for that procedure. If a required descriptor is not provided, it will fail during run time.

Presence of an Unnecessary Descriptor

The presence of a descriptor that is not required does not interfere with the called procedure's access to arguments. If an operational descriptor is not needed or expected, the called procedure simply ignores it.

Note: Descriptors can be an impediment to interlanguage communication when they are generated regardless of need. Descriptors increase the length of the call path, which can diminish performance.

Bindable APIs for Operational Descriptor Access

Descriptors are normally accessed directly by a called procedure according to the semantics of the HLL in which the procedure is written. Once a procedure is programmed to expect operational descriptors, no further handling is usually required by the programmer. However, sometimes a called procedure needs to determine whether the descriptors that it requires are present before accessing them. For this purpose the following bindable APIs are provided:

- Retrieve Operational Descriptor Information (CEEDOD) bindable API
- Get String Information (CEESGI) bindable API

Support for OPM and ILE APIs

When you develop new functions in ILE or convert an existing application to ILE, you may want to continue to support call-level APIs from OPM. This topic explains one technique that may be used to accomplish this dual support while maintaining your application in ILE.

ILE service programs provide a way for you to develop and deliver bindable APIs that may be accessed from all ILE languages. To provide the same functions to OPM programs, you need to consider the fact that an ILE service program cannot be called directly from an OPM program.

The technique to use is to develop ILE program stubs for each bindable API that you plan to support. You may want to name the bindable APIs the same as the ILE program stubs, or you may choose different names. Each ILE program stub contains a static procedure call to the actual bindable API.

An example of this technique is shown in Figure 6-4.

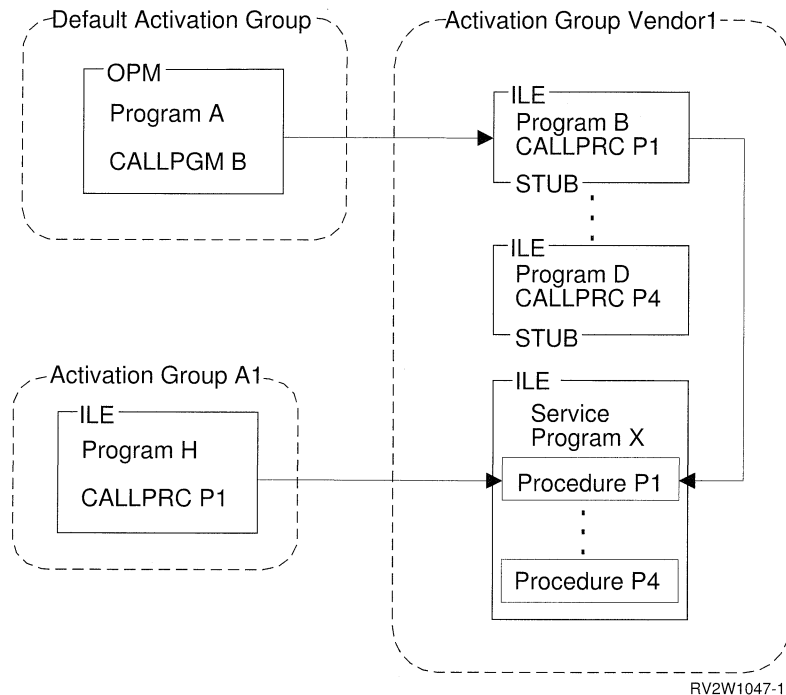

Figure 6-4. Supporting OPM and ILE APIs

Programs B through D are the ILE program stubs. Service program X contains the actual implementation of each bindable API. Each program stub and the service program are given the same activation group name. In this example, the activation group name VENDOR1 is chosen.

Activation group VENDOR1 is created by the system when necessary. The dynamic program call from OPM program A creates the activation group on the first call from an OPM program. The static procedure call from ILE program H creates the activation group when ILE program H is activated. Once the activation group exists, it may be used from either program A or program H.

You should write the implementation of your API in an ILE procedure (procedure P1 in this example). This procedure may be called either directly through a procedure call or indirectly through a dynamic program call. You should not implement any functions such as sending exception messages that depend on a specific call stack structure. A normal return from either the program stub or the implementing procedure leaves the activation group in the job for later use. You can implement your API procedure with the knowledge that a control boundary is established for either the program stub or the implementing procedure on each call. HLL end verbs delete the activation group whether the call originated from an OPM program or an ILE program.

Chapter 7. Storage Management

The operating system provides storage support for the ILE high-level languages. This storage support removes the need for unique storage managers for the run-time environment of each language. It avoids incompatibilities between different storage managers and mechanisms in high-level languages.

The operating system provides the automatic, static, and dynamic storage used by programs and procedures at run time. Automatic and static storage are managed by the operating system. That is, the need for automatic and static storage is known at compilation time from program variable declarations. Dynamic storage is managed by the program or procedure. The need for dynamic storage is known only at run time.

When program activation occurs, static storage for program variables is allocated and initialized.

When a program begins to run, automatic storage is allocated. The automatic storage stack is extended for variables in a program or procedure as the program or procedure is added to the call stack.

As a program runs, dynamic storage is allocated under program control. This storage is extended as additional storage is required. You have the ability to control dynamic storage. The remainder of this chapter concentrates on dynamic storage and the ways in which it can be controlled.

Dynamic Storage

The operating system allows the use of multiple heaps that are dynamically created and discarded. A **heap** is an area of storage used for allocations of dynamic storage. The amount of dynamic storage required by an application depends on the data being processed by the programs and procedures that use the heap.

Heap Characteristics

Each heap has the following characteristics:

- A heap is assigned a unique heap identifier.

The heap identifier for the default heap is always zero.

A storage management bindable API, called by a program or procedure, uses the heap identifier to identify the heap on which it is to act. The bindable API must run within the activation group that owns the heap.

- A heap is owned by the activation group that creates it.

Because activation groups own heaps, the lifetime of a heap is no longer than that of the owning activation group. The heap identifier is meaningful and unique only within the activation group that owns it.

- The size of a heap is dynamically extended to satisfy allocation requests.

The maximum size of the heap is 4 gigabytes minus 512K bytes. This is the maximum heap size if the total number of allocations (at any one time) does not exceed 128 000.

- The maximum size of any single allocation from a heap is limited to 16 megabytes minus 64K bytes.

Default Heap

The first request for dynamic storage within an activation group results in the creation of a default heap from which the storage allocation takes place. (This assumes that you do not explicitly create a heap on the first request for dynamic storage.) Additional requests for dynamic storage are met by further allocations from the default heap. If there is insufficient storage in the heap to satisfy the current request for dynamic storage, the heap is extended and the additional storage is allocated.

Allocated dynamic storage remains allocated until it is explicitly freed or until the heap is discarded. The default heap is discarded only when the owning activation group ends.

Programs in the same activation group automatically share dynamic storage if that storage has been allocated from the default heap. However, you can isolate the dynamic storage used by some programs and procedures within an activation group. You do this by creating one or more heaps.

User-Created Heaps

You can explicitly create and discard one or more heaps by using ILE bindable APIs. This gives you the capability of managing the heaps and the dynamic storage allocated from those heaps.

For example, dynamic storage allocated in user-created heaps for programs within an activation group may or may not be shared. The sharing of dynamic storage depends on which heap identifier is referenced by the programs. You can use more than one heap to avoid automatic sharing of dynamic storage. In this way you can isolate logical groups of data. Following are some additional reasons for using one or more user-created heaps:

- You can group certain storage objects together to meet a one-time requirement. Once that requirement has been met, you can free the dynamic storage that was allocated by a single call to the Discard Heap (CEEDSHP) bindable API. This operation frees the dynamic storage and discards the heap. In this way, dynamic storage is available to meet other requests.
- You can re-use dynamic storage allocated from a heap by using the Mark Heap (CEEMKHP) and Release Heap (CEERLHP) bindable APIs. The CEEMKHP bindable API allows you to identify both a storage allocation and all subsequent allocations. When you are ready to free the group of allocations identified by the mark, use the CEERLHP bindable API. Using the mark and release functions leaves the heap intact but frees the dynamic storage that had been allocated from it. In this way, you can avoid the system overhead associated with heap creation by re-using existing heaps to meet dynamic storage requirements.

- Your storage requirements may not match the storage attributes that define the default heap. For example, the initial size of the default heap is 4K bytes. However, you require a number of dynamic storage allocations that together exceed 4K bytes. You can create a heap with a larger initial size than 4K bytes, and by doing this you can meet your long-term dynamic storage requirements. Similarly, you can have heap extensions larger than 4K bytes. For information about defining heap sizes, see “Heap Allocation Strategy” on page 7-4 and the discussion of heap attributes.

You may have other reasons for using multiple heaps rather than the default heap. The storage management bindable APIs give you the capability to manage both the heaps that you create and the dynamic storage allocated in those heaps. See the *System API Reference* for an explanation of the storage management bindable APIs.

Single-Heap Support

Languages that do not have intrinsic multiple-heap storage support, such as ILE C/400, use the default heap. You cannot use the Discard Heap (CEEDSHP), the Mark Heap (CEEMKHP), or the Release Heap (CEERLHP) bindable APIs with the default heap. The only way to free dynamic storage allocated by the default heap is by explicit free operations, or when the owning activation group ends.

In this case, the use of the default heap ensures that allocated dynamic storage is not inadvertently released in mixed-language applications. Release heap and discard heap operations are considered insecure for large applications that re-use existing code with potentially different storage support. If release heap operations were valid for the default heap, procedures could correctly use different storage management capabilities separately. However, those storage management capabilities might fail when they are used in combination.

ILE C/400 Heap Support

ILE C/400 provides optional heap support to that provided by the system.

If you choose to use this optional support, the following rules apply:

- Dynamic storage allocated through the C functions `malloc()`, `calloc()`, and `realloc()`, cannot be freed or reallocated with the `CEEFRST` and the `CEECZST` bindable APIs.
- Dynamic storage allocated by the `CEEGTST` bindable API can be freed with the `free()` function.
- Dynamic storage initially allocated with the `CEEGTST` bindable API can be reallocated with the `realloc()` function.

If you do not choose this optional support, you can use both the storage management bindable APIs and the `malloc()`, `calloc()`, `realloc()`, and `free()` functions.

Other languages, such as COBOL, have no heap storage model. These languages can access the ILE dynamic storage model through the bindable APIs for dynamic storage.

Heap Allocation Strategy

The attributes associated with the default heap are defined by the system through a default allocation strategy. This allocation strategy defines attributes such as a heap creation size of 4K bytes and an extension size of 4K bytes. You cannot change this default allocation strategy.

However, you can control heaps that you explicitly create through the Create a Heap (CEE4RHP) bindable API. You also can define an allocation strategy for explicitly created heaps through the Define Heap Allocation Strategy (CEE4DAS) bindable API. Then, when you explicitly create a heap, the heap attributes are provided by the allocation strategy that you defined. In this way you can define separate allocation strategies for one or more explicitly created heaps.

You can use the CEE4RHP bindable API without defining an allocation strategy. In this case, the heap is defined by the attributes of the `_CEE4ALC` allocation strategy type. The `_CEE4ALC` allocation strategy type specifies a heap creation size of 4K bytes and an extension size of 4K bytes. The `_CEE4ALC` allocation strategy type contains the following attributes:

```
Max_Sngl_Alloc = 16MB - 64K /* maximum size of a single allocation */
Min_Bdy        = 16        /* minimum boundary alignment of any allocation */
Crt_Size       = 4K        /* initial creation size of the heap */
Ext_Size       = 4K        /* the extension size of the heap */
Alloc_Strat    = 0         /* a choice for allocation strategy */
No_Mark        = 1         /* a group deallocation choice */
Blk_Xfer       = 0         /* a choice for block transfer of a heap */
PAG            = 0         /* a choice for heap creation in a PAG */
Alloc_Init     = 0         /* a choice for allocation initialization */
Init_Value     = 0x00      /* initialization value */
```

The attributes are shown here to illustrate the structure of the `_CEE4ALC` allocation strategy type. For a full explanation of the attributes, see the description of the `_CEE4ALC` allocation strategy type in the *System API Reference*.

Storage Management Bindable APIs

Bindable APIs are provided for all heap operations. Applications can be written using either the bindable APIs, language-intrinsic functions, or both.

The bindable APIs fall into the following categories:

- Basic heap operations. These operations can be used on the default heap and on user-created heaps.

The Free Storage (CEE4FRST) bindable API frees one previous allocation of heap storage.

The Get Heap Storage (CEE4GTST) bindable API allocates storage within a heap.

The Reallocate Storage (CEE4CZST) bindable API changes the size of previously allocated storage.

- Extended heap operations. These operations can be used only on user-created heaps.

The Create Heap (CEE4CRHP) bindable API creates a new heap.

The Discard Heap (CEE4DSHP) bindable API discards an existing heap.

The Mark Heap (CEE4MKHP) bindable API returns a token that can be used to identify heap storage to be freed by the CEE4RLHP bindable API.

The Release Heap (CEE4RLHP) bindable API frees all storage allocated in the heap since the mark was specified.

- Heap allocation strategies

The Define Heap Allocation Strategy (CEE4DAS) bindable API defines an allocation strategy that determines the attributes for a heap created with the CEE4CRHP bindable API.

See the *System API Reference* for specific information about the storage management bindable APIs.

Chapter 8. Exception and Condition Management

This chapter provides additional details on exception handling and condition handling. Before you read this chapter, read the advanced concepts described in “Error Handling” on page 3-12.

The exception message architecture of the OS/400 is used to implement both exception handling and condition handling. There are cases in which exception handling and condition handling interact. For example, an ILE condition handler registered with the Register a User-Written Condition Handler (CEEHDLR) bindable API is used to handle an exception message sent with the Send Program Message (QMHSNDPM) API. These interactions are explained in this chapter. The term **exception handler** is used in this chapter to mean either an OS/400 exception handler or an ILE condition handler.

Handle Cursors and Resume Cursors

To process exceptions, the system uses two pointers called the handle cursor and resume cursor. These pointers keep track of the progress of exception handling. You need to understand the use of the handle cursor and resume cursor under certain advanced error-handling scenarios. These concepts are used to explain additional error-handling features in later topics.

The **handle cursor** is a pointer that keeps track of the current exception handler. As the system searches for an available exception handler, it moves the handle cursor to the next handler in the exception handler list defined by each call stack entry. This list can contain:

- Direct monitor handlers
- ILE condition handlers
- HLL-specific handlers

The handle cursor moves down the exception handler list to lower priority handlers until the exception is handled. If the exception is not handled by any of the exception handlers that have been defined for a call stack entry, the handle cursor moves to the first (highest priority) handler for the previous call stack entry.

The **resume cursor** is a pointer that keeps track of the current location at which your exception handler can resume processing after handling the exception. Normally the system sets the resume cursor to the next instruction following the occurrence of an exception. For call stack entries above the procedure that incurred the exception, the resume point is directly after the procedure or program call that currently suspended the procedure or program. To move the resume cursor to an earlier resume point, use the Move Resume Cursor (CEEMRCR) bindable API.

Figure 8-1 on page 8-2 shows an example of the handle cursor and resume cursor.

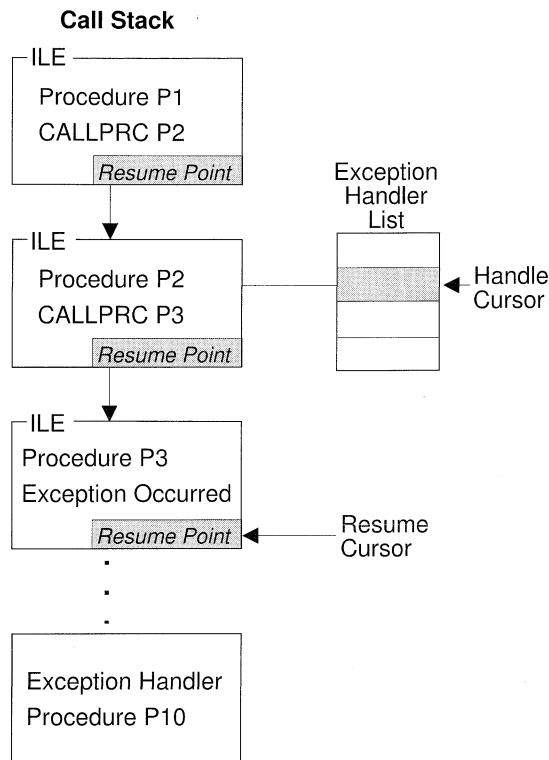

RV2W1044-0

Figure 8-1. Handle Cursor and Resume Cursor Example

The handle cursor is currently at the second exception handler defined in the exception handler priority list for procedure P2. The handler procedure P10 is currently called by the system. If procedure P10 handles the exception and returns, control goes to the current resume cursor location defined in procedure P3. This example assumes that procedure P3 percolated the exception to procedure P2.

The exception handler procedure P10 can modify the resume cursor with the Move Resume Cursor (CEEMRCR) bindable API. Two options are provided with this API. An exception handler can modify the resume cursor to either of the following:

- The call stack entry containing the handle cursor
- The call stack entry prior to the handle cursor

In Figure 8-1, you could modify the resume cursor to either procedure P2 or P1. After the resume cursor is modified and the exception is marked as handled, a normal return from your exception handler returns control to the new resume point.

Exception Handler Actions

When your exception handler is called by the system, you can take several actions to handle the exception. For example, ILE C/400 extensions support control actions, branch point handlers, and monitoring by message ID. The possible actions described here pertain to any of the following types of handlers:

- Direct monitor handler
- ILE condition handler
- HLL-specific handler

How to Resume Processing

If you determine that processing can continue, you can resume at the current resume cursor location. Before you can resume processing, the exception message must be changed to indicate that it has been handled. Certain types of handlers require you to explicitly change the exception message to indicate that the message has been handled. For other handler types, the system can change the exception message before your handler is called.

For a direct monitor handler, you may specify an action to be taken for the exception message. That action may be to call the handler, to handle the exception before calling the handler, or to handle the exception and resume the program. If the action is just to call the handler, you can still handle the exception by using the Change Exception Message (QMHCHGEM) API or the bindable API CEE4HC (Handle Condition). You can change the resume point within a direct monitor handler by using the Move Resume Cursor (CEEMRCR) bindable API. After making these changes, you continue processing by returning from your exception handler.

For an ILE condition handler, you continue processing by setting a return code value and returning to the system. For the actual return code values, please refer to the Register a User-Written Condition Handler (CEEHDLR) bindable API described in the *System API Reference*.

For an HLL-specific handler, the exception message is changed to indicate that it has been handled before your handler is called. To determine whether you can modify the resume cursor from an HLL-specific handler, refer to your ILE HLL programmer's guide.

How to Percolate a Message

If you determine that an exception message is not recognized by your handler, you can percolate the exception message to the next available handler. For percolation to occur, the exception message must not be considered as a handled message. Other exception handlers in the same or previous call stack entries are given a chance to handle the exception message. The technique for percolating an exception message varies depending on the type of exception handler.

For a direct monitor handler, do not change the exception message to indicate that it has been handled. A normal return from your exception handler causes the system to percolate the message. The message is percolated to the next exception handler in the exception handler list for your call stack entry. If your handler is at the end of the exception handler list, the message is percolated to the first exception handler in the previous call stack entry.

For an ILE condition handler, you communicate a percolate action by setting a return code value and returning to the system. For the actual return code values, please refer to the bindable API CEEHDLR described in the *System API Reference*.

For an HLL-specific handler, it may not be possible to percolate an exception message. Whether you can percolate a message depends on whether your HLL marks the message as handled before your handler is called. If you do not declare an HLL-specific handler, your HLL can percolate the unhandled exception

message. Please refer to your ILE HLL reference manual to determine the exception messages your HLL-specific handler can handle.

How to Promote a Message

Under certain limited situations, you can choose to modify the exception message to a different message. This action marks the original exception message as handled and restarts exception processing with a new exception message. This action is allowed only from direct monitor handlers and ILE condition handlers.

For direct monitor handlers, use the Promote Message (QMHPRMM) API to promote a message. Only status and escape message types can be promoted. With this API you have some control over where the handle cursor is placed to continue exception processing. Refer to the *System API Reference* for information on this API.

For an ILE condition handler, you communicate the promote action by setting a return code value and returning to the system. For the actual return code values, refer to the Register a User-Written Condition Handler (CEEHDLR) bindable API described in the *System API Reference*.

Default Actions for Unhandled Exceptions

If an exception message is percolated to the control boundary, the system takes a default action. If the exception is a notify message, the system sends the default reply, handles the exception, and allows the sender of the notify message to continue processing. If the exception is a status message, the system handles the exception and allows the sender of the status message to continue processing. If the exception is an escape message, the system handles the escape message and sends a function check message back to where the resume cursor is currently positioned. If the unhandled exception is a function check, all entries on the stack up to the control boundary are cancelled and the CEE9901 escape message is sent to the next prior stack entry.

Table 8-1 contains default responses that the system takes when an exception is unhandled at a control boundary.

Table 8-1 (Page 1 of 2). Default Responses to Unhandled Exceptions

Message Type	Severity of Condition	Condition Raised by the Signal a Condition (CEESGL) Bindable API	Exception Originated from Any Other Source
Status	0 (Informative message)	Return the unhandled condition.	Resume without logging the message.
Status	1 (Warning)	Return the unhandled condition.	Resume without logging the message.
Notify	0 (Informative message)	Not applicable.	Log the notify message and send the default reply.
Notify	1 (Warning)	Not applicable.	Log the notify message and send the default reply.
Escape	2 (Error)	Return the unhandled condition.	Log the escape message and send a function check message to the call stack entry of the current resume point.
Escape	3 (Severe error)	Return the unhandled condition.	Log the escape message and send a function check message to the call stack entry of the current resume point.

Table 8-1 (Page 2 of 2). Default Responses to Unhandled Exceptions

Message Type	Severity of Condition	Condition Raised by the Signal a Condition (CEESGL) Bindable API	Exception Originated from Any Other Source
Escape	4 (Critical ILE error)	Log the escape message and send a function check message to the call stack entry of the current resume point.	Log the escape message and send a function check message to the call stack entry of the current resume point.
Function check	4 (Critical ILE error)	Not applicable	End the application, and send the CEE9901 message to the caller of the control boundary.

Note: When the application is ended by an unhandled function check, the activation group is deleted if the control boundary is the oldest call stack entry in the activation group.

Nested Exceptions

A **nested exception** is an exception that occurs while another exception is being handled. When this happens, processing of the first exception is temporarily suspended. The system saves all of the associated information such as the locations of the handle cursor and resume cursor. Exception handling begins again with the most recently generated exception. New locations for the handle cursor and resume cursor are set by the system. Once the new exception has been properly handled, handling activities for the original exception normally resume.

When a nested exception occurs, both of the following are still on the call stack:

- The call stack entry associated with the original exception
- The call stack entry associated with the original exception handler

To reduce the possibility of exception handling loops, the system stops the percolation of a nested exception at the original exception handler call stack entry. Then the system promotes the nested exception to a function check message and percolates the function check message to the same call stack entry. If you do not handle the nested exception or the function check message, the system ends the application by calling the Abnormal End (CEE4ABN) bindable API. In this case, message CEE9901 is sent to the caller of the control boundary.

If you move the resume cursor while processing the nested exception, you can implicitly modify the original exception. To cause this to occur, do the following:

1. Move the resume cursor to a call stack entry earlier than the call stack entry that incurred the original exception
2. Resume processing by returning from your handler

Condition Handling

ILE conditions are OS/400 exception messages represented in a manner independent of the system. An ILE condition token is used to represent an ILE condition. **Condition handling** refers to the ILE functions that allow you to handle errors separately from language-specific error handling. Other SAA systems have imple-

mented these functions. You can use condition handling to increase the portability of your applications between systems that have implemented condition handling.

ILE condition handling includes the following functions:

- Ability to dynamically register an ILE condition handler
- Ability to signal an ILE condition
- Condition token architecture
- Optional condition token feedback codes for bindable ILE APIs

These functions are described in the topics that follow.

How Conditions Are Represented

The ILE **condition token** is a 12-byte compound data type that contains structured fields to convey aspects of a condition. Such aspects can be its severity, its associated message number, and information that is specific to the given instance of the condition. The condition token is used to communicate this information about a condition to the system, to message services, to bindable APIs, and to procedures. The information returned in the optional `fc` parameter of all ILE bindable APIs, for example, is communicated using a condition token.

If an exception is detected by the operating system or by the hardware, a corresponding condition token is automatically built by the system. You can also create a condition token using the Construct a Condition Token (CEENCOD) bindable API. Then you can signal a condition to the system by returning the token through the Signal a Condition (CEESGL) bindable API.

Layout of a Condition Token

Figure 8-2 displays a map of the condition token. The starting bit position is shown for each field.

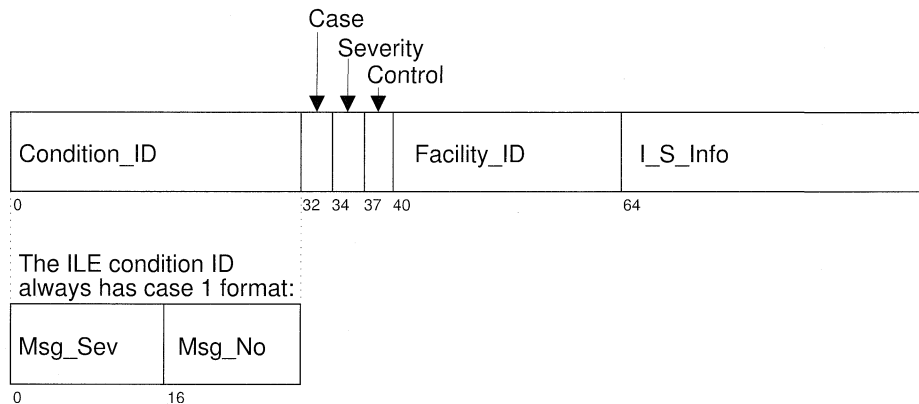

RV2W1032-1

Figure 8-2. ILE Condition Token Layout

Every condition token contains the components indicated in Figure 8-2:

Condition_ID A 4-byte identifier that, with the `Facility_ID`, describes the condition that the token communicates. ILE bindable APIs and most applications produce case 1 conditions.

Case A 2-bit field that defines the format of the `Condition_ID` portion of the token. ILE conditions are always case 1.

Severity	A 3-bit binary integer that indicates the severity of the condition. The Severity and Msg_Sev fields contain the same information. See Table 8-1 on page 8-4 for a list of ILE condition severities. See Table 8-3 on page 8-8 and Table 8-4 on page 8-8 for the corresponding OS/400 message severities.
Control	A 3-bit field containing flags that describe or control various aspects of condition handling. The third bit specifies whether the Facility_ID has been assigned by IBM.
Facility_ID	A 3-character alphanumeric string that identifies the facility that generated the condition. The Facility_ID indicates whether the message was generated by the system or an HLL run time. Table 8-2 lists the facility IDs used in ILE.
I_S_Info	A 4-byte field that identifies the instance specific information associated with a given instance of the condition. This field contains the reference key to the instance of the message associated with the condition token. If the message reference key is zero, there is no associated message.
Msg_Sev	A 2-byte binary integer that indicates the severity of the condition. Msg_Sev and Severity contain the same information. See Table 8-1 on page 8-4 for a list of ILE condition severities. See Table 8-3 on page 8-8 and Table 8-4 on page 8-8 for the corresponding OS/400 message severities.
Msg_No	A 2-byte binary number that identifies the message associated with the condition. The combination of Facility_ID and Msg_No uniquely identifies a condition.

Table 8-2 contains the facility IDs used in ILE condition tokens and in the prefix of OS/400 messages.

Table 8-2. Facility IDs Used in Messages and ILE Condition Tokens

Facility ID	Facility
CEE	ILE common library
CPF	OS/400 XPF message
MCH	OS/400 machine exception message

Condition Token Testing

You can test a condition token that is returned from a bindable API for the following:

- Success** To test for success, determine if the first 4 bytes are zero. If the first 4 bytes are zero, the remainder of the condition token is zero, indicating a successful call was made to the bindable API.
- Equivalent Tokens** To determine whether two condition tokens are equivalent (that is, the same *type* of condition token, but not the same *instance* of the condition token), compare the first 8 bytes of each condition token with one another. These bytes are the same for all instances of a given condition.
- Equal Tokens** To determine whether two condition tokens are equal, (that is, they represent the same instance of a condition), compare all 12 bytes of each condition token with one another. The last 4 bytes can change from instance to instance of a condition.

Relationship of ILE Conditions to OS/400 Messages

A message is associated with every condition that is raised in ILE. The condition token contains a unique ID that ILE uses to write a message associated with the condition to the message file.

The format of every run-time message is **FFFxxxx**:

- FFF** The facility ID, a 3-character ID that is used by all messages generated under ILE and ILE languages. Refer to Table 8-2 on page 8-7 for a list of IDs and corresponding facilities.
- xxxx** The error message number. This is a hexadecimal number that identifies the error message associated with the condition.

Table 8-3 and Table 8-4 show how ILE condition severity maps to OS/400 message severity.

*Table 8-3. Mapping AS/400 *ESCAPE Message Severities to ILE Condition Severities*

From AS/400 Message Severity	To ILE Condition Severity	To AS/400 Message Severity
0-29	2	20
30-39	3	30
40-99	4	40

*Table 8-4. Mapping AS/400 *STATUS and *NOTIFY Message Severities to ILE Condition Severities*

From AS/400 Message Severity	To ILE Condition Severity	To AS/400 Message Severity
0	0	0
1-99	1	10

OS/400 Messages and the Bindable API Feedback Code

As input to a bindable API, you have the option of coding a feedback code, and using the feedback code as a return (or feedback) code check in a procedure. The feedback code is a condition token value that is provided for flexibility in checking returns from calls to other procedures. You can then use the feedback code as input to a condition token. If the feedback code is omitted on the call to a bindable API and a condition occurs, an exception message is sent to the caller of the bindable API.

If you code the feedback code parameter in your application to receive feedback information from a bindable API, the following sequence of events occurs when a condition is raised:

1. An informational message is sent to the caller of the API, communicating the message associated with the condition.
2. The bindable API in which the condition occurred builds a condition token for the condition. The bindable API places information into the instance specific information area. The instance specific information of the condition token is the message reference key of the informational message. This is used by the system to react to the condition.
3. If a detected condition is critical (severity is 4), the system sends an exception message to the caller of the bindable API.
4. If a detected condition is not critical (severity less than 4), the condition token is returned to the routine that called the bindable API.
5. When the condition token is returned to your application, you have the following options:
 - Ignore it and continue processing.
 - Signal the condition using the Signal a Condition (CEESGL) bindable API.
 - Get, format, and dispatch the message for display using the Get, Format, and Dispatch a Message (CEEMSG) bindable API.
 - Store the message in a storage area using the Get a Message (CEEMGET) bindable API.
 - Use the Dispatch a Message (CEEMOUT) bindable API to dispatch a user-defined message to a destination that you specify.
 - When the caller of the API regains control, the informational message is removed and does not appear in the job log.

If you omit the feedback code parameter when you are calling a bindable API, the bindable API sends an exception message to the caller of the bindable API.

Chapter 9. Debugging Considerations

The source debugger is used to debug ILE programs and service programs. CL commands can still be used to debug original program model (OPM) programs.

This chapter presents several considerations about the source debugger. Information on how to use the source debugger can be found in the online information and in the programmer's guide for the ILE high-level language (HLL) you are using. Information on the commands to use for a specific task (for example, creating a module) can be found in your ILE HLL programmer's guide.

Debug Mode

To use the source debugger, your session must be in debug mode. **Debug mode** is a special environment in which program testing functions can be used in addition to normal system functions.

Your session is put into debug mode when you run the Start Debug (STRDBG) command.

Addition of Programs to Debug Mode

A program must be added to debug mode before it can be debugged. OPM programs, ILE programs, and ILE service programs can be in debug mode at the same time. As many as 10 OPM programs can be in debug mode at one time. The number of ILE programs and service programs that can be in debug mode at one time is not limited. However, the maximum amount of debug data that is supported at one time is 16MB per module.

You must have *CHANGE authority to a program or service program to add it to debug mode. A program or service program can be added to debug mode when it is stopped on the call stack.

ILE programs and service programs are accessed by the source debugger one module at a time. When you are debugging an ILE program or service program, you may need to debug a module in another program or service program. That second program or service program must be added to debug mode before the module in the second program can be debugged.

When debug mode ends, all programs are removed from debug mode.

How Observability and Optimization Affect Debugging

Whether a module is observable and whether it is fully optimized affect the ability to debug it.

Module **observability** refers to data that can be stored with a module that allows it to be changed without being compiled again. **Optimization** is a process where the system looks for processing shortcuts that reduce the amount of system resources necessary to produce the same output.

Observability

Module observability consists of two types of data:

Debug Data	Represented by the *DBGDTA value. This data is necessary to allow a module to be debugged.
Creation Data	Represented by the *CRTDTA value. This data is necessary to translate the code to machine instructions. The module must have this data for you to change the module optimization level.

Once a module is compiled, you can only remove this data. Using the Change Module (CHGMOD) command, you can remove either type of data from the module, or remove both types. Removing all observability reduces the module to its minimum size (with compression). Once this data is removed, you cannot change the module in any way unless you compile the module again and replace the data. To compile it again, you must have authority to the source code.

Optimization Levels

Generally, if a module has creation data, you can change the level at which the source code is optimized to run on the system. Processing shortcuts are translated into machine code, allowing the procedures in the module to run more efficiently. The higher the optimization level, the more efficiently the procedures in the module run.

However, with more optimization you cannot change variables and may not be able to view the actual value of a variable during debugging. When you are debugging, set the optimization level to the minimum level (*NONE). This provides the lowest level of performance for the procedures in the module but allows you to accurately display and change variables. After you have completed your debugging, set the optimization level to the maximum level (*FULL). This provides the highest level of performance for the procedures in the module.

Debug Data Creation and Removal

Debug data is stored with each module and is generated when a module is created. To debug a procedure in a module that has been created without debug data, you must re-create the module with debug data. Then rebind the module to the ILE program or service program. You do not have to recompile all the other modules in the program or service program that already have debug data.

To remove debug data from a module, re-create the module without debug data or use the Change Module (CHGMOD) command.

Module Views

The levels of debug data available may vary for each module in an ILE program or service program. The modules are compiled separately and could be produced with different compilers and options. These debug data levels determine which **views** are produced by the compiler and which views are displayed by the source debugger. Possible values are:

***NONE** No debug views are produced.

*STMT	No source is displayed by the debugger, but breakpoints can be added using procedure names and statement numbers found on the compiler listing. The amount of debug data stored with this view is the minimum amount of data necessary for debugging.
*SOURCE	The source debugger displays source if the source files used to compile the module are still present on the system.
*LIST	The list view is produced and stored with the module. This allows the source debugger to display source even if the source files used to create the module are not present on the system. This view can be useful as a backup copy if the program will be changed. However, the amount of debug data may be quite large, especially if other files are expanded into the listing. The compiler options used when the modules were created determine whether the includes are expanded. Files that can be expanded include DDS files and include files (such as ILE C/400 includes, IEL RPG/400 /COPY files, and ILE COBOL/400 COPY files).
*ALL	All debug views are produced. As for the list view, the amount of debug data may be very large.

ILE RPG/400 also has a debug option *COPY that produces both a source view and a copy view. The copy view is a debug view that has all the /COPY source members included.

Debugging across Jobs

You may want to use a separate job to debug programs running in your job or a batch job. This is very useful when you want to observe the function of a program without the interference of debugger panels. For example, the panels or windows that an application displays may overlay or be overlaid by the debugger panels during stepping or at breakpoints. You can avoid this problem by starting a service job and starting the debugger in a different job from the one that is being debugged. For information on this, see the appendix on testing in the *CL Programming* book.

Unmonitored Exceptions

When an unmonitored exception occurs, the program that is running issues a function check and sends a message to the job log. If you are in debug mode and the modules of the program were created with debug data, the source debugger shows the Display Module Source display. The program is added to debug mode if necessary. The appropriate module is shown on the display with the affected line highlighted. You can then debug the program.

National Language Support Restriction for Debugging

If either of the following conditions exist:

- The coded character set identifier (CCSID) of the debug job is 290, 930, or 5026 (Japan Katakana)
- The code page of the device description used for debugging is 290, 930, or 5026 (Japan Katakana)

debug commands, functions, and hexadecimal literals should be entered in uppercase. For example:

```
BREAK 16 WHEN var=X'A1B2'  
EVAL var:X
```

The above restriction for Japan Katakana code pages does not apply when using identifier names in debug commands (for example, EVAL). However, when debugging ILE RPG/400, ILE COBOL/400, or ILE CL modules, identifier names in debug commands are converted to uppercase by the source debugger and therefore may be redisplayed differently.

Chapter 10. Data Management Scoping

This chapter contains information on the data management resources that may be used by an ILE program or service program. Before reading this chapter, you should understand the data management scoping concepts described in “Data Management Scoping Rules” on page 3-19.

Details for each resource type are left to each ILE HLL programmer’s guide.

Common Data Management Resources

This topic identifies all the data management resources that follow data management scoping rules. Following each resource is a brief description of how to specify the scoping. Additional details for each resource can be found in the publications referred to.

- Open file operations

Open file operations result in the creation of a temporary resource called an open data path (ODP). The open function can be started by using HLL open verbs, the Open Query File (OPNQRYF) command, or the Open Data Base File (OPNDBF) command. The ODP is scoped to the activation group of the program that opened the file. For OPM or ILE programs that run in the default activation group, the ODP is scoped to the call-level number. To change the scoping of HLL open verbs, an override may be used. You can specify scoping by using the open scope (OPNSCOPE) parameter on all override commands, the OPNDBF command, and the OPNQRYF command. For more information about open file operations, see the *Data Management* book.

- Overrides

Overrides are scoped to the call level, the activation group level, or the job level. To specify override scoping, use the override scope (OVRSCOPE) parameter on any override command. If explicit scoping is not specified, the scope of the override depends on where the override is issued. If the override is issued from the default activation group, it is scoped to the call level. If the override is issued from any other activation group, it is scoped to the activation group level. For more information about overrides, see the *Data Management* book.

- Commitment definitions

Commitment definitions support scoping to the activation group level and scoping to the job level. The scoping level is specified with the control scope (CTLSCOPE) parameter on the Start Commitment Control (STRCMTCTL) command. For more information about commitment definitions, see *Backup and Recovery – Advanced*.

- Local SQL cursors

SQL programs may be created for ILE compiler products. The SQL cursors used by an ILE program may be scoped to either the module or activation group. You may specify the SQL cursor scoping through the end SQL (ENDSQL) parameter on the Create SQL Program commands. For more information about local SQL cursors, see the *DB2/400 SQL Programming* book.

- Remote SQL connections

Remote connections used with SQL cursors are scoped to an activation group implicitly as part of normal SQL processing. This allows multiple conversations to exist among one source job and multiple target jobs or systems. For more information about remote SQL connections, see the *DB2/400 SQL Programming* book.

- User interface manager

The Open Print Application (QUIOPNPA) and Open Display Application APIs support an application scope parameter. These APIs can be used to scope the user interface manager (UIM) application to either an activation group or the job. For more information about the user interface manager, see the *System API Reference*.

- Open data links (open file management)

The Enable Link (QOLELINK) API enables a data link. If this API is used from within an ILE activation group, the data link is scoped to that activation group. If this API is used from within the default activation group, the data link is scoped to the call level. For more information about open data links, see the *System API Reference*.

- Common Programming Interface (CPI) Communications conversations

The activation group that starts a conversation owns that conversation. The activation group that enables a link through the Enable Link (QOLELINK) API owns the link. For more information about Common Programming Interface (CPI) Communications conversations, see the *System API Reference*.

- Hierarchical file system

The Open Stream File (OHFOPNSF) API manages hierarchical file system (HFS) files. The open information (OPENINFO) parameter on this API may be used to control scoping to either the activation group or the job level. For more information about the hierarchical file system, see the *System API Reference*.

Commitment Control Scoping

ILE introduces two changes for commitment control:

- Multiple, independent commitment definitions per job. Transactions can be committed and rolled back independently of each other. Before ILE, only a single commitment definition was allowed per job.
- If changes are pending when an activation group ends normally, the system implicitly commits the changes. Before ILE, the system did not commit the changes.

Commitment control allows you to define and process changes to resources, such as database files or tables, as a single transaction. A **transaction** is a group of individual changes to objects on the system that should appear to the user as a single atomic change. Commitment control ensures that one of the following occurs on the system:

- The entire group of individual changes occurs (a **commit** operation)
- None of the individual changes occur (a **rollback** operation)

Various resources can be changed under commitment control using both OPM programs and ILE programs.

The Start Commitment Control (STRCMTCTL) command makes it possible for programs that run within a job to make changes under commitment control. When commitment control is started by using the STRCMTCTL command, the system creates a **commitment definition**. Each commitment definition is known only to the job that issued the STRCMTCTL command. The commitment definition contains information pertaining to the resources being changed under commitment control within that job. The commitment control information in the commitment definition is maintained by the system as the commitment resources change. The commitment definition is ended by using the End Commitment Control (ENDCMTCTL) command. For more information about commitment control, see *Backup and Recovery – Advanced*.

Commitment Definitions and Activation Groups

Multiple commitment definitions can be started and used by programs running within a job. Each commitment definition for a job identifies a separate transaction that has resources associated with it. These resources can be committed or rolled back independently of all other commitment definitions started for the job.

Note: Only ILE programs can start commitment control for activation groups other than the default activation group. Therefore, a job can use multiple commitment definitions only if the job is running one or more ILE programs.

Original program model (OPM) programs run in the default activation group. By default, OPM programs use the *DFACTGRP commitment definition. For OPM programs, you can use the *JOB commitment definition by specifying CMTSCOPE(*JOB) on the STRCMTCTL command.

When you use the Start Commitment Control (STRCMTCTL) command, you specify the scope for a commitment definition on the commitment scope (CMTSCOPE) parameter. The **scope** for a commitment definition indicates which programs that run within the job use that commitment definition. The default scope for a commitment definition is to the activation group of the program issuing the STRCMTCTL command. Only programs that run within that activation group will use that commitment definition. Commitment definitions that are scoped to an activation group are referred to as commitment definitions at the **activation-group level**. The commitment definition started at the activation-group level for the OPM default activation group is known as the default activation-group (*DFACTGRP) commitment definition. Commitment definitions for many activation-group levels can be started and used by programs that run within various activation groups for a job.

A commitment definition can also be scoped to the job. A commitment definition with this scope value is referred to as the **job-level** or *JOB commitment definition. Any program running in an activation group that does not have a commitment definition started at the activation-group level uses the job-level commitment definition. This occurs if the job-level commitment definition has already been started by another program for the job. Only a single job-level commitment definition can be started for a job.

For a given activation group, only a single commitment definition can be used by the programs that run within that activation group. Programs that run within an activation group can use the commitment definition at either the job level or the

activation-group level. However, they cannot use both commitment definitions at the same time.

When a program performs a commitment control operation, the program does not directly indicate which commitment definition to use for the request. Instead, the system determines which commitment definition to use based on which activation group the requesting program is running in. This is possible because, at any point in time, the programs that run within an activation group can use only a single commitment definition.

Ending Commitment Control

Commitment control may be ended for either the job-level or activation-group-level commitment definition by using the End Commitment Control (ENDCMTCTL) command. The ENDCMTCTL command indicates to the system that the commitment definition for the activation group of the program making the request is to be ended. The ENDCMTCTL command ends one commitment definition for the job. All other commitment definitions for the job remain unchanged.

If the commitment definition at the activation-group level is ended, programs running within that activation group can no longer make changes under commitment control. If the job-level commitment definition is started or already exists, any new file open operations specifying commitment control use the job-level commitment definition.

If the job-level commitment definition is ended, any program running within the job that was using the job-level commitment definition can no longer make changes under commitment control. If commitment control is started again with the STRCMTCTL command, changes can be made.

Commitment Control during Activation Group End

When the following conditions exist at the same time:

- An activation group ends
- The job is not ending

the system automatically ends a commitment definition at an activation-group level. If both of the following conditions exist:

- Uncommitted changes exist for a commitment definition at an activation-group level
- The activation group is ending normally

the system performs an implicit commit operation for the commitment definition before it ends the commitment definition. Otherwise, if either of the following conditions exist:

- The activation group is ending abnormally
- The system encountered errors when closing any files opened under commitment control scoped to the activation group

an implicit rollback operation is performed for the commitment definition at the activation-group level before being ended. Because the activation group ends abnormally, the system updates the notify object with the last successful commit operation. Commit and rollback are based on pending changes. If there are no pending changes, there is no rollback, but the notify object is still updated. If the activation group ends abnormally with pending changes, the system implicitly rolls

| back the changes. If the activation group ends normally with pending changes, the
| system implicitly commits the changes.

An implicit commit operation or rollback operation is never performed during activation group end processing for the *JOB or *DFACTGRP commitment definitions. This is because the *JOB and *DFACTGRP commitment definitions are never ended because of an activation group ending. Instead, these commitment definitions are either explicitly ended by an ENDCMTCTL command or ended by the system when the job ends.

The system automatically closes any files scoped to the activation group when the activation group ends. This includes any database files scoped to the activation group opened under commitment control. The close operation for any such file occurs before any implicit commit operation that is performed for the commitment definition at the activation-group level. Therefore, any records that reside in an I/O buffer are first forced to the database before any implicit commit operation is performed.

As part of the implicit commit operation or rollback operation, the system calls the API commit and rollback exit program for each API commitment resource. Each API commitment resource must be associated with the commitment definition at the activation-group level. After the API commit and rollback exit program is called, the system automatically removes the API commitment resource.

If the following conditions exist:

- An implicit rollback operation is performed for a commitment definition that is being ended because an activation group is being ended
- A notify object is defined for the commitment definition

the notify object is updated.

Chapter 11. ILE Bindable Application Programming Interfaces

ILE bindable application programming interfaces (bindable APIs) are an important part of ILE. In some cases they provide additional function beyond that provided by a specific high-level language. For example, not all HLLs offer intrinsic means to manipulate dynamic storage. In those cases, you can supplement an HLL function by using particular bindable APIs. If your HLL provides the same function as a particular bindable API, use the HLL-specific one.

Bindable APIs are HLL independent. This can be useful for mixed-language applications. For example, if you use only condition management bindable APIs with a mixed-language application, you will have uniform condition handling semantics for that application. This makes condition management more consistent than when using multiple HLL-specific condition handlers.

The bindable APIs provide a wide range of function including:

- Activation group and control flow management
- Condition management
- Date and time manipulation
- Dynamic screen management
- Math functions
- Message handling
- Program or procedure call management
and operational descriptor access
- Source debugger
- Storage management

For reference information on the ILE bindable APIs, see the *System API Reference*.

ILE Bindable APIs Available

Most bindable APIs are available to any HLL that ILE supports. Naming conventions of the bindable APIs are as follows:

- Bindable APIs with names beginning with CEE are based on the SAA Language Environment* specifications. These APIs are intended to be consistent across the IBM SAA systems. For more information about the SAA Language Environment, see the *SAA CPI Language Environment Reference*.
- Bindable APIs with names beginning with CEE4 or CEES4 are specific to the AS/400 system.

ILE provides the following bindable APIs:

Activation Group and Control Flow Bindable APIs

- Abnormal End (CEE4ABN)
- Find a Control Boundary (CEE4FCB)
- Register Activation Group Exit Procedure (CEE4RAGE)
- Register Call Stack Entry Termination User Exit Procedure (CEERTX)
- Signal the Termination-Imminent Condition (CEETREC)
- Unregister Call Stack Entry Termination User Exit Procedure (CEEUTX)

Condition Management Bindable APIs

- Construct a Condition Token (CEENCOD)
- Decompose a Condition Token (CEEDCOD)
- Handle a Condition (CEE4HC)
- Move the Resume Cursor to a Return Point (CEEMRCR)
- Register a User-Written Condition Handler (CEEHDLR)
- Retrieve ILE Version and Platform ID (CEEGPID)
- Return the Relative Invocation Number (CEE4RIN)
- Signal a Condition (CEESGL)
- Unregister a User Condition Handler (CEEHDLU)

Date and Time Bindable APIs

- Calculate Day-of-Week from Lillian Date (CEEDYWK)
- Convert Date to Lillian Format (CEEDAYS)
- Convert Integers to Seconds (CEEISEC)
- Convert Lillian Date to Character Format (CEEDATE)
- Convert Seconds to Character Timestamp (CEEDATM)
- Convert Seconds to Integers (CEESECI)
- Convert Timestamp to Number of Seconds (CEESECS)
- Get Current Greenwich Mean Time (CEEGMT)
- Get Current Local Time (CEELOCT)
- Get Offset from Universal Time Coordinated to Local Time (CEEUTCO)
- Get Universal Time Coordinated (CEEUTC)
- Query Century (CEEQCEN)
- Return Default Date and Time Strings for Country (CEEFMDT)
- Return Default Date String for Country (CEEFMDA)
- Return Default Time String for Country (CEEFMTM)
- Set Century (CEESCEN)

Math Bindable APIs

The x in the name of each math bindable API refers to one of the following data types:

- I** 32-bit binary integer
- S** 32-bit single floating-point number
- D** 64-bit double floating-point number
- T** 32-bit single floating-complex number (both real and imaginary parts are 32 bits long)
- E** 64-bit double floating-complex number (both real and imaginary parts are 64 bits long)

Absolute Function (CEESxABS)
Arccosine (CEESxACS)
Arcsine (CEESxASN)
Arctangent (CEESxATN)
Arctangent2 (CEESxAT2)
Conjugate of Complex (CEESxCJG)
Cosine (CEESxCOS)
Cotangent (CEESxCTN)
Error Function and Its Complement (CEESxERx)
Exponential Base e (CEESxEXP)
Exponentiation (CEESxXPx)
Factorial (CEE4SIFAC)
Floating Complex Divide (CEESxDVD)
Floating Complex Multiply (CEESxMLT)
Gamma Function (CEESxGMA)
Hyperbolic Arctangent (CEESxATH)
Hyperbolic Cosine (CEESxCSH)
Hyperbolic Sine (CEESxSNH)
Hyperbolic Tangent (CEESxTNH)
Imaginary Part of Complex (CEESxIMG)
Log Gamma Function (CEESxLGM)
Logarithm Base 10 (CEESxLG1)
Logarithm Base 2 (CEESxLG2)
Logarithm Base e (CEESxLOG)
Modular Arithmetic (CEESxMOD)
Nearest Integer (CEESxNIN)
Nearest Whole Number (CEESxNWN)
Positive Difference (CEESxDIM)
Sine (CEESxSIN)
Square Root (CEESxSQT)
Tangent (CEESxTAN)
Transfer of Sign (CEESxSGN)
Truncation (CEESxINT)

Additional math bindable API:

Basic Random Number Generation (CEERAN0)

Message Handling Bindable APIs

Dispatch a Message (CEEMOUT)
Get a Message (CEEMGET)
Get, Format, and Dispatch a Message (CEEMSG)

Program or Procedure Call Bindable APIs

Get String Information (CEEGSI)
Retrieve Operational Descriptor Information (CEEDOD)
Test for Omitted Argument (CEETSTA)

Source Debugger Bindable APIs

Allow a Program to Issue Debug Statements
(QteSubmitDebugCommand)
Enable a Session to Use the Source Debugger
(QteStartSourceDebug)
Map Positions from One View to Another (QteMapViewPosition)
Register a View of a Module (QteRegisterDebugView)

Remove a View of a Module (QteRemoveDebugView)
Retrieve the Attributes of the Source Debug Session (QteRetrieveDebugAttribute)
Retrieve the List of Modules and Views for a Program (QteRetrieveModuleViews)
Retrieve the Position Where the Program Stopped (QteRetrieveStoppedPosition)
Retrieve Source Text from the Specified View (QteRetrieveViewText)
Set the Attributes of the Source Debug Session (QteSetDebugAttribute)
Take a Job Out of Debug Mode (QteEndSourceDebug)

Storage Management Bindable APIs

Create Heap (CEE4RHP)
Define Heap Allocation Strategy (CEE4DAS)
Discard Heap (CEE4SHP)
Free Storage (CEE4FRST)
Get Heap Storage (CEE4GTST)
Mark Heap (CEE4MKHP)
Reallocate Storage (CEE4CZST)
Release Heap (CEE4RLHP)

Dynamic Screen Manager Bindable APIs

The dynamic screen manager (DSM) bindable APIs are a set of screen I/O interfaces that provide a dynamic way to create and manage display screens for the ILE high-level languages.

The DSM APIs fall into the following functional groups:

- **Low-level services**

The low-level services APIs provide a direct interface to the 5250 data stream commands. The APIs are used to query and manipulate the state of the display screen; to create, query, and manipulate input and command buffers that interact with the display screen; and to define fields and write data to the display screen.

- **Window services**

The window services APIs are used to create, delete, move, and resize windows; and to manage multiple windows concurrently during a session.

- **Session services**

The session services APIs provide a general paging interface that can be used to create, query, and manipulate sessions; and to perform input and output operations to sessions.

For more information about the DSM bindable APIs, see the *System API Reference*.

Appendix A. Output Listing from CRTPGM, CRTSRVPGM, UPDPGM, or UPDSRVPGM Command

This appendix shows examples of binder listings and explains errors that could occur as a result of using the binder language.

Binder Listing

The binder listings for the Create Program (CRTPGM), Create Service Program (CRTSRVPGM), Update Program (UPDPGM), and Update Service Program (UPDSRVPGM) commands are almost identical. This topic presents a binder listing from the CRTSRVPGM command used to create the FINANCIAL service program in "Binder Language Examples" on page 4-13.

Three types of listings can be specified on the detail (DETAIL) parameter of the CRTPGM, CRTSRVPGM, UPDPGM, or UPDSRVPGM commands:

- *BASIC
- *EXTENDED
- *FULL

Basic Listing

If you specify DETAIL(*BASIC) on the CRTPGM, CRTSRVPGM, UPDPGM, or UPDSRVPGM command, the listing consists of the following:

- The values specified on the CRTPGM, CRTSRVPGM, UPDPGM, or UPDSRVPGM command
- A brief summary table
- Data showing the length of time some pieces of the binding process took to complete

Figure A-1, Figure A-2, and Figure A-3 on page A-2 show this information.

```

                                Create Service Program                                Page 1
Service program . . . . . : FINANCIAL
Library . . . . . : MYLIB
Export . . . . . : *SRCFILE
Export source file . . . . . : QSRVSRC
Library . . . . . : MYLIB
Export source member . . . . . : *SRVPGM
Activation group . . . . . : *CALLER
Creation options . . . . . : *GEN *NODUPPROC *NODUPVAR *DUPWARN
Listing detail . . . . . : *FULL
User profile . . . . . : *USER
Replace existing service program . . . . . : *YES
Authority . . . . . : *LIBCRTAUT
Text . . . . . :

Module      Library      Module      Library      Module      Library      Module      Library
MONEY       MYLIB       CALCS       MYLIB
RATES       MYLIB       ACCTS       MYLIB

Service     Library     Service     Library     Service     Library     Service     Library
Program     Library     Program     Library     Program     Library     Program     Library

*NONE

Binding     Library     Binding     Library     Binding     Library     Binding     Library
Directory   Library     Directory   Library     Directory   Library     Directory   Library

*NONE

```

Figure A-1. Values Specified on CRTSRVPGM Command

```

                                Create Service Program                                Page 3
                                Brief Summary Table
Program entry procedures . . . . . : 0
Multiple strong definitions . . . . . : 0
Unresolved references . . . . . : 0

***** END OF BRIEF SUMMARY TABLE *****

```

Figure A-2. Brief Summary Table

```

                                Create Service Program                                Page 23
                                Binding Statistics
Symbol collection CPU time . . . . . : .018
Symbol resolution CPU time . . . . . : .006
Binding directory resolution CPU time . . . . . : .403
Binder language compilation CPU time . . . . . : .040
Listing creation CPU time . . . . . : 1.622
Program/service program creation CPU time . . . . . : .178

Total CPU time . . . . . : 2.761
Total elapsed time . . . . . : 11.522

***** END OF BINDING STATISTICS *****

*CPC5D0B - Service program FINANCIAL created in library MYLIB.

***** END OF CREATE SERVICE PROGRAM LISTING *****

```

Figure A-3. Binding Statistics

Extended Listing

If you specify `DETAIL(*EXTENDED)` on the `CRTPGM`, `CRTSRVPGM`, `UPDPGM`, or `UPDSRVPGM` command, the listing includes all the information provided by `DETAIL(*BASIC)` plus an extended summary table. The extended summary table shows the number of imports (references) that were resolved and the number of exports (definitions) processed. For the `CRTSRVPGM` or `UPDSRVPGM` command, the listing also shows the binder language used, the signatures generated, and which imports (references) matched which exports (definitions). Figure A-4, Figure A-5 on page A-4, and Figure A-6 on page A-5 show examples of the additional data.

Create Service Program		Page 2
Extended Summary Table		
Valid definitions :	418	
Strong :	418	
Weak :	0	
Resolved references :	21	
To strong definitions :	21	
To weak definitions :	0	
***** END OF EXTENDED SUMMARY TABLE *****		

Figure A-4. Extended Summary Listing

Binder Information Listing

Module : MONEY
 Library : MYLIB
 Bound : *YES

Number	Symbol	Ref	Identifier	Type	Scope	Export	Key
00000001	Def		main	Proc	Module	Strong	
00000002	Def		Amount	Proc	SrvPgm	Strong	
00000003	Def		Payment	Proc	SrvPgm	Strong	
00000004	Ref	0000017F	Q LE AG_prod_rc	Data			
00000005	Ref	0000017E	Q LE AG_user_rc	Data			
00000006	Ref	000000AC	_C_main	Proc			
00000007	Ref	00000180	Q LE leDefaultEh	Proc			
00000008	Ref	00000181	Q LE mhConversionEh	Proc			
00000009	Ref	00000125	_C_exception_router	Proc			

Module : RATES
 Library : MYLIB
 Bound : *YES

Number	Symbol	Ref	Identifier	Type	Scope	Export	Key
0000000A	Def		Term	Proc	SrvPgm	Strong	
0000000B	Def		Rate	Proc	SrvPgm	Strong	
0000000C	Ref	0000017F	Q LE AG_prod_rc	Data			
0000000D	Ref	0000017E	Q LE AG_user_rc	Data			
0000000E	Ref	00000180	Q LE leDefaultEh	Proc			
0000000F	Ref	00000181	Q LE mhConversionEh	Proc			
00000010	Ref	00000125	_C_exception_router	Proc			

Module : CALCS
 Library : MYLIB
 Bound : *YES

Number	Symbol	Ref	Identifier	Type	Scope	Export	Key
00000011	Def		Calc1	Proc	Module	Strong	
00000012	Def		Calc2	Proc	Module	Strong	
00000013	Ref	0000017F	Q LE AG_prod_rc	Data			
00000014	Ref	0000017E	Q LE AG_user_rc	Data			
00000015	Ref	00000180	Q LE leDefaultEh	Proc			
00000016	Ref	00000181	Q LE mhConversionEh	Proc			
00000017	Ref	00000125	_C_exception_router	Proc			

Module : ACCTS
 Library : MYLIB
 Bound : *YES

Number	Symbol	Ref	Identifier	Type	Scope	Export	Key
00000018	Def		OpenAccount	Proc	SrvPgm	Strong	
00000019	Def		CloseAccount	Proc	SrvPgm	Strong	
0000001A	Ref	0000017F	Q LE AG_prod_rc	Data			
0000001B	Ref	0000017E	Q LE AG_user_rc	Data			
0000001C	Ref	00000180	Q LE leDefaultEh	Proc			
0000001D	Ref	00000181	Q LE mhConversionEh	Proc			
0000001E	Ref	00000125	_C_exception_router	Proc			

Figure A-5 (Part 1 of 2). Binder Information Listing

Service program :	QC2SYS						
Library :	*LIBL						
Bound :	*NO						
Number	Symbol	Ref	Identifier	Type	Scope	Export	Key
0000001F	Def		system	Proc		Strong	
Service program :	QLEAWI						
Library :	*LIBL						
Bound :	*YES						
Number	Symbol	Ref	Identifier	Type	Scope	Export	Key
0000017E	Def		Q LE AG_user_rc	Data		Strong	
0000017F	Def		Q LE AG_prod_rc	Data		Strong	
00000180	Def		Q LE 1eDefaultEh	Proc		Strong	
00000181	Def		Q LE mhConversionEh	Proc		Strong	

Figure A-5 (Part 2 of 2). Binder Information Listing

```

                                Create Service Program                                Page 14
                                Binder Language Listing

STRPGMEXP PGMLVL(*CURRENT)
EXPORT SYMBOL('Term')
EXPORT SYMBOL('Rate')
EXPORT SYMBOL('Amount')
EXPORT SYMBOL('Payment')
EXPORT SYMBOL('OpenAccount')
EXPORT SYMBOL('CloseAccount')
ENDPGMEXP
***** Export signature: 0000000ADCFEE088738A98DBA6E723.
STRPGMEXP PGMLVL(*PRV)
EXPORT SYMBOL('Term')
EXPORT SYMBOL('Rate')
EXPORT SYMBOL('Amount')
EXPORT SYMBOL('Payment')
ENDPGMEXP
***** Export signature: 0000000000000000ADC89D09E0C6E7.

***** END OF BINDER LANGUAGE LISTING *****

```

Figure A-6. Binder Language Listing

Full Listing

|
|

If you specify `DETAIL(*FULL)` on the `CRTPGM`, `CRTSRVPGM`, `UPDPGM`, or `UPDSRVPGM` command, the listing includes all the detail provided for `DETAIL(*EXTENDED)` plus a cross-reference listing. Figure A-7 on page A-6 shows a partial example of the additional data provided.

Cross-Reference Listing

Identifier	Defs	-----Refs-----		Type	Library	Object
		Ref	Ref			
.
.
xlatewt	000000DD			*SRVPGM	*LIBL	QC2UTIL1
yn	00000140			*SRVPGM	*LIBL	QC2UTIL2
y0	0000013E			*SRVPGM	*LIBL	QC2UTIL2
y1	0000013F			*SRVPGM	*LIBL	QC2UTIL2
Amount	00000002			*MODULE	MYLIB	MONEY
Calc1	00000011			*MODULE	MYLIB	CALCS
Calc2	00000012			*MODULE	MYLIB	CALCS
CloseAccount	00000019			*MODULE	MYLIB	ACCTS
CEECRHP	000001A0			*SRVPGM	*LIBL	QLEAWI
CEECZST	0000019F			*SRVPGM	*LIBL	QLEAWI
CEEDATE	000001A9			*SRVPGM	*LIBL	QLEAWI
CEEDATM	000001B1			*SRVPGM	*LIBL	QLEAWI
CEEDAYS	000001A8			*SRVPGM	*LIBL	QLEAWI
CEEDCOD	00000187			*SRVPGM	*LIBL	QLEAWI
CEEDSHP	000001A1			*SRVPGM	*LIBL	QLEAWI
CEEDYWK	000001B3			*SRVPGM	*LIBL	QLEAWI
CEEFMDA	000001AD			*SRVPGM	*LIBL	QLEAWI
CEEFMDT	000001AF			*SRVPGM	*LIBL	QLEAWI
CEEFMTM	000001AE			*SRVPGM	*LIBL	QLEAWI
CEEFRST	0000019E			*SRVPGM	*LIBL	QLEAWI
CEEGMT	00000186			*SRVPGM	*LIBL	QLEAWI
CEEGPID	00000195			*SRVPGM	*LIBL	QLEAWI
CEEGTST	0000019D			*SRVPGM	*LIBL	QLEAWI
CEEISEC	00000180			*SRVPGM	*LIBL	QLEAWI
CEELOCT	00000184			*SRVPGM	*LIBL	QLEAWI
CEEMGET	00000183			*SRVPGM	*LIBL	QLEAWI
CEEMKHP	000001A2			*SRVPGM	*LIBL	QLEAWI
CEEMOUT	00000184			*SRVPGM	*LIBL	QLEAWI
CEEMRCR	00000182			*SRVPGM	*LIBL	QLEAWI
CEEMSG	00000185			*SRVPGM	*LIBL	QLEAWI
CEENCOD	00000186			*SRVPGM	*LIBL	QLEAWI
CEEQCEN	000001AC			*SRVPGM	*LIBL	QLEAWI
CEERLHP	000001A3			*SRVPGM	*LIBL	QLEAWI
CEEScen	000001AB			*SRVPGM	*LIBL	QLEAWI
CEESECI	000001B2			*SRVPGM	*LIBL	QLEAWI
CEESECS	000001AA			*SRVPGM	*LIBL	QLEAWI
CEESGL	00000190			*SRVPGM	*LIBL	QLEAWI
CEETREC	00000191			*SRVPGM	*LIBL	QLEAWI
CEEUTC	000001B5			*SRVPGM	*LIBL	QLEAWI
CEEUTC0	000001B7			*SRVPGM	*LIBL	QLEAWI
CEE4ABN	00000192			*SRVPGM	*LIBL	QLEAWI
CEE4CpyDvfb	0000019A			*SRVPGM	*LIBL	QLEAWI
CEE4CpyIofb	00000199			*SRVPGM	*LIBL	QLEAWI
CEE4CpyOfb	00000198			*SRVPGM	*LIBL	QLEAWI
CEE4DAS	000001A4			*SRVPGM	*LIBL	QLEAWI
CEE4FCB	0000018A			*SRVPGM	*LIBL	QLEAWI
CEE4HC	00000197			*SRVPGM	*LIBL	QLEAWI
CEE4RAGE	0000018B			*SRVPGM	*LIBL	QLEAWI
CEE4RIN	00000196			*SRVPGM	*LIBL	QLEAWI
OpenAccount	00000018			*MODULE	MYLIB	ACCTS
Payment	00000003			*MODULE	MYLIB	MONEY
Q LE 1eBdyCh	00000188			*SRVPGM	*LIBL	QLEAWI
Q LE 1eBdyEpilog	00000189			*SRVPGM	*LIBL	QLEAWI
Q LE 1eDefaultEh	00000180	00000007	0000000E	*SRVPGM	*LIBL	QLEAWI
	00000015		0000001C			
Q LE mhConversionEh	00000181	00000008	0000000F	*SRVPGM	*LIBL	QLEAWI
	00000016		0000001D			
Q LE AG_prod_rc	0000017F	00000004	0000000C	*SRVPGM	*LIBL	QLEAWI
	00000013	0000001A				
Q LE AG_user_rc	0000017E	00000005	0000000D	*SRVPGM	*LIBL	QLEAWI
		00000014	0000001B			
Q LE Hd1rRouterEh	0000018F			*SRVPGM	*LIBL	QLEAWI
Q LE RtxRouterCh	0000018E			*SRVPGM	*LIBL	QLEAWI
Rate	0000000B			*MODULE	MYLIB	RATES
Term	0000000A			*MODULE	MYLIB	RATES

Figure A-7. Cross-Reference Listing

Listing for Example Service Program

Figure A-3 on page A-2, Figure A-5 on page A-4, and Figure A-7 on page A-6 show some of the listing data generated when DETAIL(*FULL) was specified to create the FINANCIAL service program in Figure 4-7 on page 4-18. The figures show the binding statistics, the binder information listing, and the cross-reference listing.

Binder Information Listing for Example Service Program

The binder information listing (Figure A-5 on page A-4) includes the following data and column headings:

- The library and name of the module or service program that was processed.
If the *Bound* field shows a value of *YES for a module object, the module is marked to be bound by copy. If the *Bound* field shows a value of *YES for a service program, the service program is bound by reference. If the *Bound* field shows a value of *NO for either a module object or service program, that object is not included in the bind. The reason is that the object did not provide an export that satisfied an unresolved import.
- Number
For each module or service program that was processed, a unique identifier (ID) is associated with each export (definition) or import (reference).
- Symbol
This column identifies the symbol name as an export (Def) or an import (Ref).
- Ref
A number specified in this column (Ref) is the unique ID of the export (Def) that satisfies the import request. For example, in Figure A-5 on page A-4 the unique ID for the import 00000005 matches the unique ID for the export 0000017E.
- Identifier
This is the name of the symbol that is exported or imported. The symbol name imported for the unique ID 00000005 is Q LE AG_user_rc. The symbol name exported for the unique ID 0000017E is also Q LE AG_user_rc.
- Type
If the symbol name is a procedure, it is identified as Proc. If the symbol name is a data item, it is identified as Data.
- Scope
For modules, this column identifies whether an exported symbol name is accessed at the module level or at the public interface to a service program. If a program is being created, the exported symbol names can be accessed only at the module level. If a service program is being created, the exported symbol names can be accessed at the module level or the service program (SrvPgm) level. If an exported symbol is a part of the public interface, the value in the *Scope* column must be SrvPgm.
- Export
This column identifies the strength of a data item exported from a module or service program. The strength of an exported data item depends on the programming language. The strength determines when enough is known about a

data item to set its characteristics, such as its size. A strong export's characteristics are set at bind time.

- If one or more weak exports have the same name as a strong export, the binder uses the characteristics of the strong export.
- If a weak export does not have the same name as a strong export, its characteristics cannot be set until activation time. At activation time, if multiple weak exports with the same name exist, the largest one is used unless an already activated weak export with the same name has already set its characteristics.

Weak exports can be exported outside a program object or service program to be resolved at activation time. Strong exports cannot be exported outside a program object. Strong exports can be exported outside a service program to satisfy either of the following:

- Imports in a program that binds the service program by reference
 - Imports in other service programs bound by reference to that program
- Key
This column contains additional information about any weak exports. Typically this column is blank.

Cross-Reference Listing for Example Service Program

The cross-reference listing in Figure A-7 on page A-6 is another way of looking at the data presented in the binder information. The cross-reference listing includes the following column headings:

- Identifier
The name of the export that was processed during symbol resolution.
- Defs
The unique ID associated with each export.
- Refs
A number in this column indicates the unique ID of the import (Ref) that was resolved to this export (Def).
- Type
Identifies whether the export came from a *MODULE or a *SRVPGM object.
- Library
The library name as it was specified on the command or in the binding directory.
- Object
The name of the object that provided the export (Def).

Binding Statistics for Example Service Program

Figure A-3 on page A-2 shows a set of statistics for creating the service program FINANCIAL. The statistics identify where the binder spent time when it was processing the create request. You have only indirect control over the data presented in this section. Some amount of processing overhead cannot be measured. Therefore, the value listed in the *Total CPU time* field is larger than the sum of the times listed in the preceding fields.

Binder Language Errors

While the system is processing the binder language during the creation of a service program, an error might occur. If `DETAIL(*EXTENDED)` or `DETAIL(*FULL)` is specified on the Create Service Program (`CRTSRVPGM`) command, you can see the errors in the spooled file.

The following information messages could occur:

- Signature padded
- Signature truncated

The following warning errors could occur:

- Current export block limits interface
- Duplicate export block
- Duplicate symbol on previous export
- Level checking cannot be disabled more than once, ignored
- Multiple current export blocks not allowed, previous assumed

The following serious errors could occur:

- Current export block is empty
- Export block not completed, end-of-file found before `ENDPGMEXP`
- Export block not started, `STRPGMEXP` required
- Export blocks cannot be nested, `ENDPGMEXP` missing
- Exports must exist inside export blocks
- Identical signatures for dissimilar export blocks, must change exports
- No current export block
- Previous export block is empty
- Signature contains variant characters
- `SIGNATURE(*GEN)` required with `LVLCHK(*NO)`
- Signature syntax not valid
- Symbol name required
- Symbol not allowed as service program export
- Symbol not defined
- Syntax not valid

Signature Padded

Figure A-8 shows a binder language listing that contains this message.

```

                                     Binder Language Listing

      STRPGMEXP SIGNATURE('Short signature')
***** Signature padded
      EXPORT    SYMBOL('Proc_2')
      ENDPGMEXP

***** Export signature: E2889699A340A289879581A3A4998540.

      * * * * *   E N D   O F   B I N D E R   L A N G U A G E   L I S T I N G   * * * * *
```

Figure A-8. The Signature Provided Was Shorter than 16 Bytes, So It Is Padded

This is an information message.

Suggested Changes

No changes are required.

If you wish to avoid the message, make sure that the signature being provided is exactly 16 bytes long.

Signature Truncated

Figure A-9 shows a binder language listing that contains this message.

```

                                     Binder Language Listing

      STRPGMEXP SIGNATURE('This signature is very long')
***** Signature truncated
      EXPORT    SYMBOL('Proc_2')
      ENDPGMEXP

***** Export signature: E38889A240A289879581A3A499854089.

      * * * * *   E N D   O F   B I N D E R   L A N G U A G E   L I S T I N G   * * * * *
```

Figure A-9. Only the First 16 Bytes of Data Provided Are Used for the Signature

This is an information message.

Suggested Changes

No changes are required.

If you wish to avoid the message, make sure that the signature being provided is exactly 16 bytes long.

Current Export Block Limits Interface

Figure A-10 shows a binder language listing that contains this error.

```
Binder Language Listing

STRPGMEXP PGMLVL(*CURRENT)
  EXPORT SYMBOL(A)
  EXPORT SYMBOL(B)
ENDPGMEXP
***** Export signature: 000000000000000000000000000000CD2.
STRPGMEXP PGMLVL(*PRV)
  EXPORT SYMBOL(A)
  EXPORT SYMBOL(B)
  EXPORT SYMBOL(C)
ENDPGMEXP
***** Export signature: 000000000000000000000000000000CDE3.
***** Current export block limits interface.

          * * * * *   E N D   O F   B I N D E R   L A N G U A G E   L I S T I N G   * * * * *
```

Figure A-10. A PGMLVL(*PRV) Exported More Symbols than the PGMLVL(*CURRENT)

This is a warning error.

A PGMLVL(*PRV) export block has specified more symbols than the PGMLVL(*CURRENT) export block.

If no other errors occurred, the service program is created.

If both of the following are true:

- PGMLVL(*PRV) had supported a procedure named C
- Under the new service program, procedure C is no longer supported

any ILE program or service program that called procedure C in this service program gets an error at run time.

Suggested Changes

1. Make sure that the PGMLVL(*CURRENT) export block has more symbols to be exported than a PGMLVL(*PRV) export block.
2. Run the CRTSRVPGM command again.

In this example, the EXPORT SYMBOL(C) was incorrectly added to the STRPGMEXP PGMLVL(*PRV) block instead of to the PGMLVL(*CURRENT) block.

Duplicate Export Block

Figure A-11 shows a binder language listing that contains this error.

```
                                Binder Language Listing

STRPGMEXP  PGMLVL(*CURRENT)
  EXPORT SYMBOL(A)
  EXPORT SYMBOL(B)
ENDPGMEXP
***** Export signature: 000000000000000000000000000000CD2.
STRPGMEXP  PGMLVL(*PRV)
  EXPORT SYMBOL(A)
  EXPORT SYMBOL(B)
ENDPGMEXP
***** Export signature: 000000000000000000000000000000CD2.
***** Duplicate export block.

                                * * * * *  E N D  O F  B I N D E R  L A N G U A G E  L I S T I N G  * * * * *
```

Figure A-11. Duplicate STRPGMEXP/ENDPGMEXP Blocks

This is a warning error.

More than one STRPGMEXP and ENDPGMEXP block exported all the same symbols in the exact same order.

If no other errors occurred, the service program is created. The duplicated signature is included only once in the created service program.

Suggested Changes

1. Make one of the following changes:
 - Make sure that the PGMLVL(*CURRENT) export block is correct. Update it as appropriate.
 - Remove the duplicate export block.
2. Run the CRTSRVPGM command again.

In this example, the STRPGMEXP command with PGMLVL(*CURRENT) specified needs to have the following source line added after EXPORT SYMBOL(B):

```
EXPORT  SYMBOL(C)
```

Level Checking Cannot Be Disabled More than Once, Ignored

Figure A-13 shows a binder language listing that contains this error.

```
Binder Language Listing

STRPGMEXP  PGMLVL(*CURRENT) LVLCHK(*NO)
  EXPORT SYMBOL(A)
  EXPORT SYMBOL(B)
ENDPGMEXP
***** Export signature: 00000000000000000000000000000000.
STRPGMEXP  PGMLVL(*PRV) LVLCHK(*NO)
***** Level checking cannot be disabled more than once, ignored
  EXPORT SYMBOL(A)
ENDPGMEXP
***** Export signature: 00000000000000000000000000000000C1.

          * * * * *   E N D   O F   B I N D E R   L A N G U A G E   L I S T I N G   * * * * *
```

Figure A-13. Multiple STRPGMEXP Commands Have LVLCHK(*NO) Specified

This is a warning error.

More than one STRPGMEXP blocks specified LVLCHK(*NO).

If no other errors occurred, the service program is created. The second and subsequent LVLCHK(*NO) are assumed to be LVLCHK(*YES).

Suggested Changes

1. Make sure that only one STRPGMEXP block has LVLCHK(*NO) specified.
2. Run the CRTSRVPGM command again.

In this example, the PGMLVL(*PRV) export block is the only export block that has LVLCHK(*NO) specified. The LVLCHK(*NO) value is removed from the PGMLVL(*CURRENT) export block.

Multiple Current Export Blocks Not Allowed, Previous Assumed

Figure A-14 shows a binder language listing that contains this error.

```
Binder Language Listing

STRPGMEXP PGMLVL(*CURRENT)
  EXPORT SYMBOL(A)
  EXPORT SYMBOL(B)
  EXPORT SYMBOL(C)
ENDPGMEXP
***** Export signature: 0000000000000000000000000000CDE3.
STRPGMEXP
  EXPORT SYMBOL(A)
***** Multiple 'current' export blocks not allowed, 'previous' assumed.
  EXPORT SYMBOL(B)
ENDPGMEXP
***** Export signature: 0000000000000000000000000000CD2.

      * * * * *   E N D   O F   B I N D E R   L A N G U A G E   L I S T I N G   * * * * *
```

Figure A-14. More than One PGMLVL(*CURRENT) Value Specified

This is a warning error.

A value of PGMLVL(*CURRENT) was specified or was allowed to default to PGMLVL(*CURRENT) on more than one STRPGMEXP command. The second and subsequent export blocks with a value of PGMLVL(*CURRENT) are assumed to be PGMLVL(*PRV).

If no other errors occurred, the service program is created.

Suggested Changes

1. Change the appropriate source text to STRPGMEXP PGMLVL(*PRV).
2. Run the CRTSRVPGM command again.

In this example, the second STRPGMEXP is the one to change.

Current Export Block Is Empty

Figure A-15 shows a binder language listing that contains this error.

```
                                Binder Language Listing

STRPGMEXP  PGMLVL(*CURRENT)
ENDPGMEXP
***** Export signature: 00000000000000000000000000000000.
***ERROR Current export block is empty.

                                * * * * *  E N D  O F  B I N D E R  L A N G U A G E  L I S T I N G  * * * * *
```

Figure A-15. No Symbols to Be Exported from the STRPGMEXP PGMLVL(*CURRENT) Block

This is a serious error.

No symbols are identified to be exported from the *CURRENT export block.

The service program is not created.

Suggested Changes

1. Make one of the following changes:

- Add the symbol names to be exported.
- Remove the empty STRPGMEXP-ENDPGMEXP block, and make another STRPGMEXP-ENDPGMEXP block as PGMLVL(*CURRENT).

2. Run the CRTSRVPGM command.

In this example, the following source line is added to the binder language source file between the STRPGMEXP and ENDPGMEXP commands:

```
EXPORT SYMBOL(A)
```

Export Block Not Completed, End-of-File Found before ENDPGMEXP

Figure A-16 shows a binder language listing that contains this error.

```
Binder Language Listing

STRPGMEXP PGMLVL(*CURRENT)
***ERROR Syntax not valid.
***ERROR Export block not completed, end-of-file found before ENDPGMEXP.

* * * * *   E N D   O F   B I N D E R   L A N G U A G E   L I S T I N G   * * * * *
```

Figure A-16. No ENDPGMEXP Command Found, but the End of the Source File Was Found

This is a serious error.

No ENDPGMEXP was found before the end of the file was reached.

The service program is not created.

Suggested Changes

1. Make one of the following changes:
 - Add the ENDPGMEXP command in the appropriate place.
 - Remove any STRPGMEXP command that does not have a matching ENDPGMEXP command, and remove any symbol names to be exported.
2. Run the CRTSRVPGM command.

In this example, the following lines are added after the STRPGMEXP command:

```
EXPORT SYMBOL(A)
ENDPGMEXP
```

Export Block Not Started, STRPGMEXP Required

Figure A-17 shows a binder language listing that contains this error.

```
                                Binder Language Listing

ENDPGMEXP
***ERROR Export block not started, STRPGMEXP required.
***ERROR No 'current' export block

                                * * * * *   E N D   O F   B I N D E R   L A N G U A G E   L I S T I N G   * * * * *

```

Figure A-17. STRPGMEXP Command Is Missing

This is a serious error.

No STRPGMEXP command was found prior to finding an ENDPGMEXP command.

The service program is not created.

Suggested Changes

1. Make one of the following changes:

- Add the STRPGMEXP command.
- Remove any exported symbols and the ENDPGMEXP command.

2. Run the CRTSRVPGM command.

In this example, the following two source lines are added to the binder language source file before the ENDPGMEXP command.

```
STRPGMEXP
EXPORT SYMBOL(A)
```

Exports Must Exist inside Export Blocks

Figure A-19 shows a binder language listing that contains this error.

```
                                Binder Language Listing

STRPGMEXP  PGMLVL(*CURRENT)
  EXPORT SYMBOL(A)
  EXPORT SYMBOL(B)
ENDPGMEXP
***** Export signature: 00000000000000000000000000000000CD2.
  EXPORT SYMBOL(A)
***ERROR Exports must exist inside export blocks.

                                * * * * *  E N D  O F  B I N D E R  L A N G U A G E  L I S T I N G  * * * * *
```

Figure A-19. Symbol Name to Be Exported Is outside the STRPGMEXP-ENDPGMEXP Block

This is a serious error.

A symbol to be exported is not defined within a STRPGMEXP-ENDPGMEXP block.

The service program is not created.

Suggested Changes

1. Make one of the following changes:
 - Move the symbol to be exported. Put it within a STRPGMEXP-ENDPGMEXP block.
 - Remove the symbol.
2. Run the CRTSRVPGM command.

In this example, the source line in error is removed from the binder language source file.

Identical Signatures for Dissimilar Export Blocks, Must Change Exports

This is a serious error.

Identical signatures have been generated from STRPGMEXP-ENDPGMEXP blocks that exported different symbols. This error condition is highly unlikely to occur. For any set of nontrivial symbols to be exported, this error should occur only once every 3.4E28 tries.

The service program is not created.

Suggested Changes

1. Make one of the following changes:

- Add an additional symbol to be exported from the PGMLVL(*CURRENT) block.

The preferred method is to specify a symbol that is already exported. This would cause a warning error of duplicate symbols but would help ensure that a signature is unique. An alternative method is to add another symbol to be exported that has not been exported.

- Change the name of a symbol to be exported from a module, and make the corresponding change to the binder language source file.
- Specify a signature by using the SIGNATURE parameter on the Start Program Export (STRPGMEXP) command.

2. Run the CRTSRVPGM command.

No Current Export Block

Figure A-20 shows a binder language listing that contains this error.

```
                                Binder Language Listing

STRPGMEXP  PGMLVL(*PRV)
  EXPORT SYMBOL(A)
ENDPGMEXP
***** Export signature: 00000000000000000000000000000000C1.
***ERROR No 'current' export block

                                * * * * *  E N D  O F  B I N D E R  L A N G U A G E  L I S T I N G  * * * * *
```

Figure A-20. No PGMLVL(*CURRENT) Export Block

This is a serious error.

No STRPGMEXP PGMLVL(*CURRENT) is found in the binder language source file.

The service program is not created.

Suggested Changes

1. Make one of the following changes:
 - Change a PGMLVL(*PRV) to PGMLVL(*CURRENT).
 - Add a STRPGMEXP-ENDPGMEXP block that is the correct *CURRENT export block.
2. Run the CRTSRVPGM command.

In this example, the PGMLVL(*PRV) is changed to PGMLVL(*CURRENT).

Previous Export Block Is Empty

Figure A-21 shows a binder language listing that contains this error.

```
                                Binder Language Listing

STRPGMEXP  PGMLVL(*CURRENT)
  EXPORT SYMBOL(A)
  EXPORT SYMBOL(B)
ENDPGMEXP
***** Export signature: 0000000000000000000000000000CD2.
STRPGMEXP  PGMLVL(*PRV)
ENDPGMEXP
***** Export signature: 000000000000000000000000000000.
***ERROR Previous export block is empty.

                                * * * * *  E N D  O F  B I N D E R  L A N G U A G E  L I S T I N G  * * * * *
```

Figure A-21. No PGMLVL(*CURRENT) Export Block

This is a serious error.

A STRPGMEXP PGMLVL(*PRV) was found, and no symbols were specified.

The service program is not created.

Suggested Changes

1. Make one of the following changes:
 - Add symbols to the STRPGMEXP-ENDPGMEXP block that is empty.
 - Remove the STRPGMEXP-ENDPGMEXP block that is empty.
2. Run the CRTSRVPGM command.

In this example, the empty STRPGMEXP-ENDPGMEXP block is removed from the binder language source file.

Signature Contains Variant Characters

Figure A-22 shows a binder language listing that contains this error.

```

                                     Binder Language Listing

      STRPGMEXP SIGNATURE('\!cdefghijklmnop')
***ERROR Signature contains variant characters
      EXPORT    SYMBOL('Proc_2')
      ENDPGMEXP

***** Export signature: E05A8384858687888991929394959697.

      * * * * *   E N D   O F   B I N D E R   L A N G U A G E   L I S T I N G   * * * * *

```

Figure A-22. Signature Contains Variant Characters

This is a serious error.

The signature contains characters that are not in all coded character set identifiers (CCSIDs).

The service program is not created.

Suggested Changes

1. Remove the variant characters.
2. Run the CRTSRVPGM program.

In this specific case, it is the \! that needs to be removed.

SIGNATURE(*GEN) Required with LVLCHK(*NO)

Figure A-23 shows a binder language listing that contains this error.

```

                                     Binder Language Listing

      STRPGMEXP SIGNATURE('ABCDEFGHIJKLMN') LVLCHK(*NO)
      EXPORT    SYMBOL('Proc_2')
***ERROR SIGNATURE(*GEN) required with LVLCHK(*NO)
      ENDPGMEXP

***** Export signature: C1C2C3C4C5C6C7C8C9D1D2D3D4D5D6D7.

      * * * * *   E N D   O F   B I N D E R   L A N G U A G E   L I S T I N G   * * * * *
```

Figure A-23. If LVLCHK(*NO) Is Specified, an Explicit Signature Is Not Valid

This is a serious error.

If LVLCHK(*NO) is specified, SIGNATURE(*GEN) is required.

The service program is not created.

Suggested Changes

1. Make one of the following changes:
 - Specify SIGNATURE(*GEN)
 - Specify LVLCHK(*YES)
2. Run the CRTSRVPGM command.

Signature Syntax Not Valid

Figure A-24 shows a binder language listing that contains this error.

```

                                     Binder Language Listing

      STRPGMEXP SIGNATURE('"abcdefghijk1 "')
***ERROR Signature syntax not valid
***ERROR Signature syntax not valid
***ERROR Syntax not valid.
***ERROR Syntax not valid.
      EXPORT      SYMBOL('Proc_2')
      ENDPGMEXP

      * * * * *   E N D   O F   B I N D E R   L A N G U A G E   L I S T I N G   * * * * *
```

Figure A-24. What Is Specified for the Signature Value Is Not Valid

This is a serious error.

The signature contains invalid characters.

The service program is not created.

Suggested Changes

1. Remove invalid characters from the signature value.
2. Run the CRTSRVPGM command.

In this case, remove the " characters from the signature field.

Symbol Name Required

Figure A-25 shows a binder language listing that contains this error.

```
                                Binder Language Listing

STRPGMEXP  PGMLVL(*CURRENT)
  EXPORT SYMBOL(A)
  EXPORT SYMBOL('')
***ERROR Symbol name required.
ENDPGMEXP
***** Export signature: 00000000000000000000000000000000C1.

                                * * * * *  E N D  O F  B I N D E R  L A N G U A G E  L I S T I N G  * * * * *
```

Figure A-25. No Symbol to Be Exported

This is a serious error.

No symbol name was found to export from the service program.

The service program is not created.

Suggested Changes

1. Make one of the following changes:

- Remove the line in error from the binder language source file.
- Add a symbol name to be exported from the service program.

2. Run the CRTSRVPGM command.

In this example, the source line EXPORT SYMBOL(' ') is removed from the binder language source file.

Symbol Not Allowed as Service Program Export

Figure A-26 shows a binder language listing that contains this error.

```
                                Binder Language Listing

STRPGMEXP  PGMLVL(*CURRENT)
  EXPORT SYMBOL(A)
***ERROR Symbol not allowed as service program export.
  EXPORT SYMBOL(D)
ENDPGMEXP
***** Export signature: 0000000000000000000000000000CD4.

          * * * * *   E N D   O F   B I N D E R   L A N G U A G E   L I S T I N G   * * * * *
```

Figure A-26. Symbol Name Not Valid to Export from Service Program

This is a serious error.

The symbol to be exported from the service program was not exported from one of the modules to be bound by copy. Typically the symbol specified to be exported from the service program is actually a symbol that needs to be imported by the service program.

The service program is not created.

Suggested Changes

1. Make one of the following changes:

- Remove the symbol in error from the binder language source file.
- On the MODULE parameter of the CRTSRVPGM command, specify the module that has the desired symbol to be exported.
- Add the symbol to one of the modules that will be bound by copy, and re-create the module object.

2. Run the CRTSRVPGM command.

In this example, the source line of EXPORT SYMBOL(A) is removed from the binder language source file.

Symbol Not Defined

Figure A-27 shows a binder language listing that contains this error.

```
                                Binder Language Listing

STRPGMEXP  PGMLVL(*CURRENT)
  EXPORT SYMBOL(A)
  EXPORT SYMBOL(Q)
***ERROR Symbol not defined.
ENDPGMEXP
***** Export signature: 0000000000000000000000000000CE8.

                                * * * * *  E N D  O F  B I N D E R  L A N G U A G E  L I S T I N G  * * * * *
```

Figure A-27. Symbol Not Found in the Modules That Are to Be Bound by Copy

This is a serious error.

The symbol to be exported from the service program could not be found in the modules that are to be bound by copy.

The service program is not created.

Suggested Changes

1. Make one of the following changes:
 - Remove the symbol that is not defined from the binder language source file.
 - On the MODULE parameter of the CRTSRVPGM command, specify the module that has the desired symbol to be exported.
 - Add the symbol to one of the modules that will be bound by copy, and re-create the module object.
2. Run the CRTSRVPGM command.

In this example, the source line of EXPORT SYMBOL(Q) is removed from the binder language source file.

Syntax Not Valid

This is a serious error.

The statements in the source member are not valid binder language statements.

The service program is not created.

Suggested Changes

1. Correct the source member so it contains valid binder language statements.
2. Run the CRTSRVPGM command.

Appendix B. Optimization Errors

In rare circumstances, an MCH3601 exception message may occur in programs compiled with optimization level *FULL. This appendix explains one example in which this message occurs. The same program does not receive an MCH3601 exception message when compiled with optimization level *BASIC or *NONE. Whether the message in this example occurs depends on how your ILE HLL compiler allocates storage for arrays. This example might never occur for your language.

When you ask for *FULL optimization, ILE attempts to improve performance by calculating array index references outside of loops. When you refer to an array in a loop, you are often accessing every element in order. Performance can be improved by saving the last array element address from the previous loop iteration. To accomplish this performance improvement, ILE calculates the first array element address outside the loop and saves the value for use inside the loop.

Take the following example:

```
DCL ARR[1000] INTEGER;
DCL I INTEGER;

I = init_expression; /* Assume that init_expression evaluates
                    to -1 which is then assigned to I */

/* More statements */

WHILE ( I < limit_expression )

    I = I + 1;

    /* Some statements in the while loop */

    ARR[I] = some_expression;

    /* Other statements in the while loop */

END;
```

If a reference to ARR[init_expression] would have produced an incorrect array index, this example can cause an MCH3601 exception. This is caused by ILE attempting to calculate the first array element address prior to entering the WHILE loop.

If you receive MCH3601 exceptions at optimization level *FULL, look for the following situation:

1. You have a loop that increments a variable before it uses the variable as an array element index.
2. The initial value of the index variable on entrance to the loop is negative.
3. A reference to the array using the initial value of the variable is not valid.

|
| When these conditions exist, it may be possible to do the following so that *FULL
| optimization can still be used:

- | 1. Move the part of the program that increments the variable to the bottom of the
| loop.
- | 2. Change the references to the variables as needed.

| The previous example would be changed as follows:

```
| I = init_expression + 1;  
|  
| WHILE ( I < limit_expression + 1 )  
|  
|     ARR[I] = some_expression;  
|  
|     I = I + 1;  
|  
| END;
```

| If this change is not possible, reduce the optimization level from *FULL to *BASIC
| or *NONE.

Appendix C. CL Commands Used with ILE Objects

The following lists indicate which CL commands can be used with each ILE object.

CL Commands Used with Modules

CHGMOD	Change Module
CRTCMOD	Create C Module
CRTCBLMOD	Create COBOL Module
CRTCLMOD	Create CL Module
CRTRPGMOD	Create RPG Module
DLTMOD	Delete Module
DSPMOD	Display Module
WRKMOD	Work with Module

CL Commands Used with Program Objects

CHGPGM	Change Program
CRTBNDC	Create Bound C Program
CRTBNDCBL	Create Bound COBOL Program
CRTBNDCL	Create Bound CL Program
CRTBNDRPG	Create Bound RPG Program
CRTPGM	Create Program
DLTPGM	Delete Program
DSPPGM	Display Program
DSPPGMREF	Display Program References
UPDPGM	Update Program
WRKPGM	Work with Program

CL Commands Used with Service Programs

CHGSRVPGM	Change Service Program
CRTSRVPGM	Create Service Program
DLTSRVPGM	Delete Service Program
DSPSRVPGM	Display Service Program
UPDSRVPGM	Update Service Program
WRKSRVPGM	Work with Service Program

CL Commands Used with Binding Directories

ADDBNDDIRE	Add Binding Directory Entry
CRTBNDDIR	Create Binding Directory
DLTBNDDIR	Delete Binding Directory
DSPBNDDIR	Display Binding Directory
RMVBNDDIRE	Remove Binding Directory Entry
WRKBNDDIR	Work with Binding Directory
WRKBNDDIRE	Work with Binding Directory Entry

CL Command Used with Structured Query Language

CRTSQLCI	Create Structured Query Language ILE C/400 Object
CRTSQLCBLI	Create Structured Query Language ILE COBOL/400 Object
CRTSQLRPGI	Create Structured Query Language ILE RPG/400 Object

CL Commands Used with Source Debugger

DSPMODSRC	Display Module Source
ENDDBG	End Debug
STRDBG	Start Debug

CL Commands Used to Edit the Binder Language Source File

STRPDM	Start Programming Development Manager
STRSEU	Start Source Entry Utility

The following nonrunnable commands can be entered into the binder language source file:

ENDPGMEXP	End Program Export
EXPORT	Export
STRPGMEXP	Start Program Export

Glossary

activation. A processing step that prepares a program to be run. Activation includes allocating and initializing static storage for programs in a job and completing some portions of binding. After activation, the programs are ready to run.

activation group. A partitioning of resources within a job. An activation group consists of system resources (storage for program or procedure variables, commitment definitions, and open files) allocated to one or more programs.

argument. In a high-level language (HLL) procedure call, an expression that represents a value that the calling procedure passes to the called procedure.

atomic. (1) In SQL, a characteristic of database data definition functions that allows the function to complete or return to its original state if a power interruption or abnormal end occurs. (2) In commitment control, a characteristic that allows individual changes to objects to appear as a single change.

automatic data. Data that is allocated with the same value on entry and reentry into a procedure. Values of the data on exiting from the procedure are not retained for the next entry into the procedure. The scope of automatic data is a procedure call within an activation group. Contrast with *external data* and *local data*.

automatic storage. In OS/400 application programming interfaces, an area that is created by the system when a program is called or run. Each routine can have either automatic storage or static storage. Within automatic storage, variables are defined each time the program is called or run. Contrast with *static storage*.

bind. To create a program, which can be run, by combining one or more modules created by an Integrated Language Environment (ILE) compiler. See also *binder* and *binding*.

binder. The system component that creates a bound program by packaging Integrated Language Environment (ILE) modules and resolving symbols passed between those modules.

binder language. A small set of commands (STRPGMEXP, EXPORT, and ENDPGMEXP) that defines the external interface (signature) for a service program. These commands are in a source file and cannot be run alone.

binding. The process of creating a program by packaging Integrated Language Environment (ILE) modules and resolving symbols passed between those modules.

binding directory. A list of names of modules and service programs that may be needed when creating an ILE program or service program. A binding directory is not a repository of the modules and service programs. Instead, it allows them to be referred to by name and type.

bound program. An AS/400 object that combines one or more modules created by an Integrated Language Environment (ILE) compiler.

breakpoint. A place in a program (specified by a command or a condition) where the system stops the processing of that program and gives control to the display station user or to a specified program.

call. Adds a new entry on the call stack for the called procedure or program and transfers control to the called object.

call message queue. A message queue that exists for each call stack entry within a job.

call stack. The ordered list of all programs or procedures currently started for a job. The order is last in, first out. The programs and procedures can be started explicitly with the CALL instruction, or implicitly from some other event.

call stack entry. A program or procedure in the call stack. Each call stack entry has information about the local, automatic variables for the procedure, and other resources scoped to the call stack entry such as condition handlers and cancel handlers.

commit. To make all changes permanent that were made to one or more database files since the last commit or rollback operation, and to make the changed records available to other users.

commitment control. A means of grouping database file operations that allows the processing of a group of database changes as a single unit through the Commit command or the removal of a group of database changes as a single unit through the Rollback command.

commitment definition. Information used by the system to maintain the commitment control environment throughout a routing step and, in the case of a system failure, throughout an initial program load (IPL). This information is obtained from the Start Commitment Control command, which establishes the commitment control environment, and the file open information in a routing step.

condition. In the Integrated Language Environment (ILE) model, a system-independent representation of an error condition within a high-level language. For the OS/400 program, each ILE condition has a corresponding exception message.

condition token. A 12-byte data structure, which is consistent across multiple Systems Application Software* (SAA) participating systems, that allows the application programmer to associate the condition with the underlying exception message.

control boundary. A call stack entry used as the point to which control is transferred when an unmonitored error occurs or a high-level language termination verb is used.

debug. To detect, diagnose, and eliminate errors in programs.

debug mode. A mode in which a program provides detailed output about its activities to aid a user in detecting and correcting errors in the program itself or in the configuration of the program or system.

debugger. A tool used to detect and trace errors in computer programs.

direct monitor handler. An exception handler that allows the application programmer to directly declare an exception monitor around limited high-level language source statements. For ILE C/400, this capability is enabled through a #pragma statement.

dynamic program call. A call from one program or procedure to another program (*PGM) at run time. Control is transferred to the called program.

dynamic screen manager. A set of APIs for controlling screen interaction.

dynamic storage. In application programming interfaces, an area of storage that is allocated by the programmer when a program or procedure is running. Contrast with *automatic storage* and *static storage*.

EPM. See *Extended Program Model*.

export. An external symbol defined in a module or program that is available for use by other modules or programs. See also *external symbol*. Contrast with *import*.

Extended Program Model (EPM). The set of functions for compiling source code and creating programs on the AS/400 system in high-level languages that define procedure calls.

external data. Data that is exported from one procedure and imported by another procedure. Contrast with *internal data*.

external message queue. A message queue used by all programs and procedures running within a job to send and to receive messages outside a job, for example, between an interactive job and the workstation user.

external symbol. An item defined in a high-level language program that represents such things as procedures or variables. Resolving external symbols is the means by which the binder connects modules to form a bound program or a service program.

first-in first-out (FIFO). A queuing technique in which the next request to be processed from a queue is the request of highest priority that has been on the queue for the longest time. Contrast with *last-in first-out (LIFO)*.

handle cursor. A pointer that keeps track of the current exception handler. Contrast with *resume cursor*.

heap. An object that provides dynamic storage for a procedure. The object is part of the activation group and is deleted when the activation group is deleted. See *dynamic storage*.

heap identifier. A number that identifies a heap within its activation group.

ILE. See *Integrated Language Environment*.

import. A reference to an external symbol defined in another module or program. Contrast with *export*.

instance-specific information. Data that contains the reference key to the instance of the message associated with the condition token. If the message reference key is zero, there is no associated message.

Integrated Language Environment (ILE). A set of constructs and interfaces that provides a common run-time environment and run-time bindable application programming interfaces (APIs) for all ILE-conforming high-level languages.

internal data. Data that is recognized only by the procedure or OPM program that defines it. Local data is deleted when the procedure returns control to the calling program or procedure. Contrast with *external data*.

job. A unit of work separately run by a computer. In ILE, a job is a collection of resources and data, and consists of one or more activation groups. See also *activation group*.

last-in first-out (LIFO). A queuing technique in which the next item to be retrieved is the item most recently placed on the queue. Contrast with *first-in first-out (FIFO)*.

LIFO. See *last-in first-out (LIFO)*.

local data. Data that is recognized only by the procedure that defines it. The scope of local data is that of the enclosing activation group.

module. In the Integrated Language Environment (ILE) model, the object that results from compiling source code. A module cannot be run. To be run, a module must be bound into a program object or service program.

nested exception. An exception that occurs while another exception is being handled.

observability. The property of an object, which is derived from data stored with the object, that allows source to be retrieved from the object, allows the object to be re-created without being recompiled, and allows the object to be symbolically debugged.

ODP. See *open data path (ODP)*.

open data path (ODP). A control block created when a file is opened. An ODP contains information about merged file attributes and information returned by input or output operations. The ODP only exists while the file is open.

operational descriptor. Information about an argument's size, shape, and type, which is passed by the system to the called procedure. This information is useful when the called procedure cannot precisely anticipate the form of the argument, for example, different types of strings.

OPM. See *original program model (OPM)*.

optimization level. A level of efficiency for processing a program, determined by the application programmer. When the code is optimized on the system, the system uses processing shortcuts to reduce the amount of system resources necessary to produce the same output. The processing shortcuts are then translated by the system into machine code, thus allowing the program to run more efficiently.

optimize. To maximize the performance of compiled code.

original program model (OPM). The set of functions for compiling source code and creating high-level language programs on the AS/400 system before the Integrated Language Environment (ILE) model was introduced.

parameter. (1) In the Integrated Language Environment, an identifier that defines the types of arguments that are passed to a called procedure. (2) A value sup-

plied to a command or program that is used either as input or to control the actions of the command or program.

PEP. See *program entry procedure*.

percolate. In the Integrated Language Environment (ILE) model, to decline to handle a condition. The unchanged condition is passed on to the next condition handler.

procedure. A set of self-contained high-level language statements that performs a particular task and then returns to the caller.

procedure call. A call made to a procedure within a module in a bound program. See also *static procedure call* and *procedure pointer call*. Contrast with *program call*.

procedure pointer call. A high-level language call mechanism for specifying the address of a procedure to be called. The procedure pointer call provides a way to call a procedure dynamically. For example, by manipulating arrays or tables of procedure names or addresses, the application programmer can dynamically route a procedure call to different procedures. Contrast with *static procedure call*.

program. In the Integrated Language Environment (ILE) model, the runnable object that results from binding modules together.

program call. A call made to an ILE program or to an OPM program. See also *dynamic program call*. Contrast with *procedure call*.

program entry procedure (PEP). A procedure provided by the compiler that is the entry point for an ILE program on a dynamic program call. Contrast with *user entry procedure*.

promote. To convert an unhandled condition into a new condition with a different meaning. The new condition is passed on to another condition handler.

public interface. The names of the exported procedures and data items that can be accessed by other Integrated Language Environment (ILE) objects.

resolved import. An import whose type and name exactly match the type and name of an export.

resume cursor. A pointer that keeps track of the current location at which the exception handler may resume processing after handling an exception.

resume point. An instruction in a program where processing continues after handling an exception.

return. To remove the call stack entry and transfer control back to the calling procedure or program in the previous call stack entry.

roll back. To restore data changed by an application program or user to the state at its last commitment boundary.

SAA. See *Systems Application Architecture (SAA)*.

scope. The extent to which the semantic effects of language statements reach. The scope may be to the job or to the activation group.

service program. A bound program that performs utility functions that can be called by other bound programs. See also *bound program*.

signature. A value that identifies the interfaces supported by a service program. Signatures are based on the exports and the sequence of the exports allowed from a service program.

source debugger. A tool for debugging Integrated Language Environment (ILE) programs by displaying a representation of their source code.

static procedure call. A high-level language (HLL) call statement that specifies the name of an Integrated Language Environment (ILE) procedure to be called. The name of the procedure is resolved to its address during binding. Contrast with *procedure pointer call*.

static storage. In OS/400 application programming interfaces, an area that is created by the system when a program is activated. Each routine can have either automatic storage or static storage. Within static storage, variables are defined. Contrast with *automatic storage*.

static variables. Variables declared for a program activation. There may be multiple copies of static variables for a program within a job, one copy for each activation group in which the program is activated.

strong export. An export that allows only one definition of an external symbol to be used by the binder. The first definition in the binder search is chosen, and duplicate definitions are discarded.

symbol resolution. The process the binder uses to match unresolved imports from the set of modules to be bound by copy with the set of exports provided by the specified modules and service programs.

Systems Application Architecture (SAA). An architecture defining a set of rules for designing a common user interface, programming interface, application programs, and communications support for strategic operating systems such as the OS/2, OS/400, VM, and MVS operating systems.

transaction. A group of individual changes to objects on the system that should appear as a single atomic change to the user.

translator. An OS/400 component that performs the final step in a program or module compilation. In the Integrated Language Environment (ILE) model, the translator is called the optimizing translator.

UEP. See *user entry procedure*.

unresolved import. An import whose type and name do not yet match the type and name of an export.

user entry procedure (UEP). The entry procedure, written by an application programmer, that is the target of the dynamic program call. This procedure gets control from the program entry procedure (PEP). Contrast with *program entry procedure*.

weak export. An export that allows several definitions for the same external symbol. Each weak export has an associated key value, which is the size of the data item. The binder chooses the weak export with the largest key value. Contrast with *strong export*.

Bibliography

For additional information about topics related to the ILE environment on the AS/400 system, refer to the following IBM AS/400 publications:

- *Backup and Recovery – Advanced*, SC41-3305, provides information about planning a backup and recovery strategy, the different types of media available to save and restore system data, as well as a description of how to record changes made to database files using journaling and how that information can be used for system recovery. This manual describes how to plan for and set up user auxiliary storage pools (ASPs), mirrored protection, and checksums along with other availability recovery topics. It also describes how to install the system again from backup.
- *CL Programming*, SC41-3721, provides a wide-ranging discussion of AS/400 programming topics, including a general discussion of objects and libraries, CL programming, controlling flow and communicating between programs, working with objects in CL programs, and creating CL programs. Other topics include predefined and impromptu messages and message handling, defining and creating user-defined commands and menus, application testing, including debug mode, breakpoints, traces, and display functions.
- *CL Reference*, SC41-3722, provides a description of the AS/400 control language (CL) and its OS/400 commands. (Non-OS/400 commands are described in the respective licensed program publications.) It also provides an overview of *all* the CL commands for the AS/400 system, and it describes the syntax rules needed to code them.
- *Communications Management*, SC41-3406, provides information about work management in a communications environment, communications status, tracing and diagnosing communications problems, error handling and recovery, performance, and specific line speed and subsystem storage information.
- *Data Management*, SC41-3710, provides information about using files in application programs. This manual includes information on the following topics:
 - Fundamental structure and concepts of data management support on the system.
 - Overrides and file redirection (temporarily making changes to files when an application program is run).
 - Copying files by using system commands to copy data from one place to another.
 - Tailoring a system using double-byte data.
- *DB2/400 Database Programming*, SC41-3701, provides a detailed discussion of the AS/400 database organization, including information on how to create, describe, and update database files on the system. This manual also describes how to define files to the system using OS/400 data description specifications (DDS) keywords.
- *Distributed Data Management*, SC41-3307, provides information about remote file processing. It describes how to define a remote file to OS/400 distributed data management (DDM), how to create a DDM file, what file utilities are supported through DDM, and the requirements of OS/400 DDM as related to other systems.
- *Experience RPG IV Multimedia Tutorial*, this is an interactive self-study program explaining the differences between RPG III and RPG IV and how to work within the new ILE environment. An accompanying workbook provides additional exercises and doubles as a reference upon completion of the tutorial. ILE RPG/400 code examples are shipped with the tutorial and run directly on the AS/400. Dial 1-800-IBM-CALL to order the tutorial.
- *ICF Programming*, SC41-3442, provides information needed to write application programs that use AS/400 communications and the OS/400 inter-system communications function (OS/400-ICF). This guide also contains information on data description specifications (DDS) keywords, system-supplied formats, return codes, file transfer support, and program examples.
- *ILE C/400 Programmer's Guide*, SC09-1820, provides information on how to develop applications using the ILE C/400 language. It includes information about creating, running, and debugging programs. It also includes programming considerations for interlanguage program and procedure calls, locales, exception handling, database files, externally described files, and device files. Some performance tips are also described. An appendix includes information on migrating source code from EPM C/400 or System C/400 to ILE C/400.
- *ILE C/400 Programming Reference*, SC09-1821, provides information about how to write programs that adhere to the Systems Application Architecture C Level 2 definition and use ILE C/400 specific functions such as record I/O. It also provides information on ILE C/400 machine interface library functions.
- *ILE C/400 Reference Summary*, SX09-1288, provides quick reference information about ILE C/400 command syntax, elements of C, SAA C library functions, ILE C/400 library extensions to SAA C, and ILE C/400 machine interface library extensions.

- *ILE COBOL/400 Programmer's Guide*, SC09-1522, describes how to write, compile, bind, run, debug, and maintain ILE COBOL/400 programs on the AS/400 system. It provides programming information on how to call other ILE COBOL/400 and non-ILE COBOL/400 programs, share data with other programs, use pointers, and handle exceptions. It also describes how to perform input/output operations on externally attached devices, database files, display files, and ICF files.
 - *ILE COBOL/400 Reference*, SC09-1523, describes the ILE COBOL/400 programming language. It provides information on the structure of the ILE COBOL/400 programming language and on the structure of an ILE COBOL/400 source program. It also describes all Identification Division paragraphs, Environment Division clauses, Data Division paragraphs, Procedure Division statements, and Compiler-Directing statements.
 - *ILE RPG/400 Programmer's Guide*, SC09-1525, is a guide for using the RPG IV programming language, which is an implementation of ILE RPG/400 in the Integrated Language Environment (ILE) on the AS/400 system. It includes information on creating and running programs, with considerations for procedure calls and interlanguage programming. The guide also covers debugging and exception handling and explains how to use AS/400 files and devices in RPG programs. Appendixes include information on migration to RPG IV and sample compiler listings. It is intended for people with a basic understanding of data processing concepts and of the RPG language.
 - *ILE RPG/400 Reference*, SC09-1526, provides information needed to write programs for the AS/400 system using the RPG IV programming language. This manual describes, position by position and keyword by keyword, the valid entries for all RPG specifications, and provides a detailed description of all the operation codes and built-in functions. This manual also contains information on the RPG logic cycle, arrays and tables, editing functions, and indicators.
 - *Intrasystem Communications Programming*, SC41-3447, provides information about interactive communications between two application programs on the same AS/400 system. This guide describes the communications operations that can be coded into a program that uses intrasystem communications support to communicate with another program. It also provides information on developing intrasystem communications application programs that use the OS/400 intersystem communications function (OS/400-ICF).
 - *Security – Basic*, SC41-3301, explains why security is necessary, defines major concepts, and provides information on planning, implementing, and monitoring basic security on the AS/400 system.
 - *Security – Reference*, SC41-3302, tells how system security support can be used to protect the system and the data from being used by people who do not have the proper authorization, protect the data from intentional or unintentional damage or destruction, keep security information up-to-date, and set up security on the system.
 - *System API Reference*, SC41-3801, provides information for the experienced programmer on how to use the application programming interfaces (APIs) to such OS/400 functions as:
 - Configuration
 - Database files
 - Dynamic Screen Manager
 - Message handling
 - Network management
 - Security
 - Source debugging
 - Spooled files
 - User interface
 - User object
 - User-defined communications
 - Work management
 - Working with software products
- This book includes both original program model (OPM) and Integrated Language Environment (ILE) APIs. Some of the APIs provide an alternative to the CL commands.
- *System Concepts*, SC41-3021, provides a general understanding of the concepts related to the overall design and use of the AS/400 system and its operating system. This manual includes general information about AS/400 features such as user interface, object management, work management, system management, data management, database, communications, environments, and architecture.
 - *Work Management*, SC41-3306, provides information about how to create and change a work management environment. Other topics include a description of tuning the system, collecting performance data including information on record formats and contents of the data being collected, working with system values to control or change the overall operation of the system, and a description of how to gather data to determine who is using the system and what resources are being used.
- For more information about the SAA Language Environment, refer to the following publication:
- *Systems Application Architecture* Common Programming Interface Language Environment Reference*, SC26-4970, introduces the concepts that form the basis of the Language Environment component of the SAA Common Programming Interface. The

manual describes the services that can be called by both single- and mixed-language applications. Included are descriptions of condition handling ser-

vices, date and time services, math routines, message services, and storage services.

Index

Special Characters

_CEE4ALC heap allocation strategy type 7-4

A

Abnormal End (CEE4ABN) bindable API 8-5

ACTGRP (activation group) parameter

*CALLER value 5-4

activation group creation 3-5

program activation 3-2, 3-5

activation

description 2-12

dynamic program call 6-5

program 3-1

program activation 3-8

service program 3-8, 6-2

activation group

ACTGRP (activation group) parameter

*CALLER value 5-4

activation group creation 3-2

program activation 3-2, 3-5

benefits of resource scoping 1-3

bindable APIs (application programming interfaces) 11-2

call stack example 3-2

commitment control

example 1-4

scoping 10-3

control boundary

activation group deletion 3-7

example 3-10

creation 3-4

data management scoping 3-20, 10-3

default 3-5

deletion 3-6

management 5-1

mixing COBOL with other languages 1-5

multiple applications running in same job 5-1

original program model (OPM) 3-5

reclaim resources 5-2, 5-4

resource isolation 3-3

resources 3-3

reuse 3-6

scoping 3-20, 10-3

service program 5-4

shared open data path (ODP) example 1-3

system-named 3-5, 3-7

user-named

deletion 3-7

description 3-4, 5-1

advanced concepts 3-1

ALWUPD parameter

on CRTPGM command 4-23

on CRTSRVPGM command 4-23

API (application programming interface)

Abnormal End (CEE4ABN) 8-5

activation group 11-2

CEE4ABN (Abnormal End) 8-5

CEE4DAS (Define Heap Allocation Strategy) 7-5

CEECRHP (Create Heap) 7-4, 7-5

CEECZST (Reallocate Storage) 7-4

CEEDOD (Retrieve Operational Descriptor Information) 6-7

CEEDSHP (Discard Heap) 7-2, 7-5

CEEFRST (Free Storage) 7-4

CEEGTST (Get Heap Storage) 7-4

CEEHDLR (Register User-Written Condition Handler) 3-17, 8-1

CEEHDLU (Unregister User-Written Condition Handler) 3-17

CEEMGET (Get Message) 8-9

CEEMKHP (Mark Heap) 7-2, 7-5

CEEMOUT (Dispatch Message) 8-9

CEEMRCR (Move Resume Cursor) 8-3

CEEMSG (Get, Format and Dispatch Message) 8-9

CEENCOD (Construct Condition Token) 8-6

CEERLHP (Release Heap) 7-2, 7-5

CEESGI (Get String Information) 6-7

CEESGL (Signal Condition)

condition token 8-6, 8-9

description 3-13

CEETSTA (Test for Omitted Argument) 6-5

Change Exception Message (QMCHGEM) 8-3

condition management 11-2, 11-3

Construct Condition Token (CEENCOD) 8-6

control flow 11-2

Create Heap (CEECRHP) 7-4, 7-5

date 11-2

debugger 11-3

Define Heap Allocation Strategy (CEE4DAS) 7-5

Discard Heap (CEEDSHP) 7-2, 7-5

Dispatch Message (CEEMOUT) 8-9

dynamic screen manager (DSM) 11-4

error handling 11-3

exception management 11-2, 11-3

Free Storage (CEEFRST) 7-4

Get Heap Storage (CEEGTST) 7-4

Get Message (CEEMGET) 8-9

Get String Information (CEESGI) 6-7

Get, Format and Dispatch Message (CEEMSG) 8-9

HLL independence 11-1

list of 11-2—11-4

API (application programming interface) *(continued)*

- Mark Heap (CEEMKHP) 7-2, 7-5
- math 11-2
- message handling 11-3
- Move Resume Cursor (CEEMRCR) 8-3
- naming conventions 11-1
- original program model (OPM) and ILE 6-8
- procedure call 11-3
- program call 11-3
- Promote Message (QMHPRMM) 8-4
- QCAPCMD 5-4
- QMCHGEM (Change Exception Message) 8-3
- QMHPRMM (Promote Message) 8-4
- QMHSNDPM (Send Program Message) 3-13, 8-1
- Reallocate Storage (CEECZST) 7-4
- Register User-Written Condition Handler (CEEHDLR) 3-17, 8-1
- Release Heap (CEERLHP) 7-2, 7-5
- Retrieve Operational Descriptor Information (CEEDOD) 6-7
- Send Program Message (QMHSNDPM) 3-13, 8-1
- services 1-2
- Signal Condition (CEESGL)
 - condition token 8-6, 8-9
 - description 3-13
- source debugger 11-3
- storage management 11-4
- supplementing HLL-specific run-time library 11-1
- Test for Omitted Argument (CEETSTA) 6-5
- time 11-2
- Unregister User-Written Condition Handler (CEEHDLU) 3-17

application

- multiple
 - running in same job 5-1

application development tools 1-6

application programming interface (API)

- Abnormal End (CEE4ABN) 8-5
- activation group 11-2
- CEE4ABN (Abnormal End) 8-5
- CEE4DAS (Define Heap Allocation Strategy) 7-5
- CEECRHP (Create Heap) 7-4, 7-5
- CEECZST (Reallocate Storage) 7-4
- CEEDOD (Retrieve Operational Descriptor Information) 6-7
- CEEDSHP (Discard Heap) 7-2, 7-5
- CEEFRST (Free Storage) 7-4
- CEEGTST (Get Heap Storage) 7-4
- CEEHDLR (Register User-Written Condition Handler) 3-17, 8-1
- CEEHDLU (Unregister User-Written Condition Handler) 3-17
- CEEMGET (Get Message) 8-9
- CEEMKHP (Mark Heap) 7-2, 7-5
- CEEMOUT (Dispatch Message) 8-9
- CEEMRCR (Move Resume Cursor) 8-3

application programming interface (API) *(continued)*

- CEEMSG (Get, Format and Dispatch Message) 8-9
- CEENCOD (Construct Condition Token) 8-6
- CEERLHP (Release Heap) 7-2, 7-5
- CEESGI (Get String Information) 6-7
- CEESGL (Signal Condition)
 - condition token 8-6, 8-9
 - description 3-13
- CEETSTA (Test for Omitted Argument) 6-5
- Change Exception Message (QMCHGEM) 8-3
- condition management 11-2, 11-3
- Construct Condition Token (CEENCOD) 8-6
- control flow 11-2
- Create Heap (CEECRHP) 7-4, 7-5
- date 11-2
- debugger 11-3
- Define Heap Allocation Strategy (CEE4DAS) 7-5
- Discard Heap (CEEDSHP) 7-2, 7-5
- Dispatch Message (CEEMOUT) 8-9
- dynamic screen manager (DSM) 11-4
- error handling 11-3
- exception management 11-2, 11-3
- Free Storage (CEEFRST) 7-4
- Get Heap Storage (CEEGTST) 7-4
- Get Message (CEEMGET) 8-9
- Get String Information (CEESGI) 6-7
- Get, Format and Dispatch Message (CEEMSG) 8-9
- HLL independence 11-1
- list of 11-2—11-4
- Mark Heap (CEEMKHP) 7-2, 7-5
- math 11-2
- message handling 11-3
- Move Resume Cursor (CEEMRCR) 8-3
- naming conventions 11-1
- original program model (OPM) and ILE 6-8
- procedure call 11-3
- program call 11-3
- Promote Message (QMHPRMM) 8-4
- QCAPCMD 5-4
- QMCHGEM (Change Exception Message) 8-3
- QMHPRMM (Promote Message) 8-4
- QMHSNDPM (Send Program Message) 3-13, 8-1
- Reallocate Storage (CEECZST) 7-4
- Register User-Written Condition Handler (CEEHDLR) 3-17, 8-1
- Release Heap (CEERLHP) 7-2, 7-5
- Retrieve Operational Descriptor Information (CEEDOD) 6-7
- Send Program Message (QMHSNDPM) 3-13, 8-1
- services 1-2
- Signal Condition (CEESGL)
 - condition token 8-6, 8-9
 - description 3-13
- source debugger 11-3
- storage management 11-4
- supplementing HLL-specific run-time library 11-1

- application programming interface (API) (*continued*)
 - Test for Omitted Argument (CEETSTA) 6-5
 - time 11-2
 - Unregister User-Written Condition Handler (CEEHDLU) 3-17
- argument
 - passing
 - in mixed-language applications 6-6
- argument passing
 - between languages 6-6
 - by reference 6-4
 - by value directly 6-3
 - by value indirectly 6-3
 - omitted arguments 6-5
 - to procedures 6-3
 - to programs 6-6
- automatic storage 7-1

B

- basic listing A-1
- benefit of ILE
 - binding 1-1
 - C environment 1-6
 - code optimization 1-6
 - coexistence with existing applications 1-3
 - common run-time services 1-2
 - future foundation 1-6
 - language interaction control 1-4
 - modularity 1-1
 - resource control 1-3
 - reusable components 1-2
 - source debugger 1-3
- Bibliography H-1
- bind
 - by copy 2-8, 4-3
 - by reference 2-8, 4-3
- bindable API
 - services 1-2
- bindable API (application programming interface)
 - Abnormal End (CEE4ABN) 8-5
 - activation group 11-2
 - CEE4ABN (Abnormal End) 8-5
 - CEE4DAS (Define Heap Allocation Strategy) 7-5
 - CEECRHP (Create Heap) 7-4, 7-5
 - CEECZST (Reallocate Storage) 7-4
 - CEEDOD (Retrieve Operational Descriptor Information) 6-7
 - CEEDSHP (Discard Heap) 7-2, 7-5
 - CEEFRST (Free Storage) 7-4
 - CEEGTST (Get Heap Storage) 7-4
 - CEEHDLR (Register User-Written Condition Handler) 3-17, 8-1
 - CEEHDLU (Unregister User-Written Condition Handler) 3-17
 - CEEMGET (Get Message) 8-9

- bindable API (application programming interface) (*continued*)
 - CEEMKHP (Mark Heap) 7-2, 7-5
 - CEEMOUT (Dispatch Message) 8-9
 - CEEMRCR (Move Resume Cursor) 8-3
 - CEEMSG (Get, Format and Dispatch Message) 8-9
 - CEENCOD (Construct Condition Token) 8-6
 - CEERLHP (Release Heap) 7-2, 7-5
 - CEESGI (Get String Information) 6-7
 - CEESGL (Signal Condition)
 - condition token 8-6, 8-9
 - description 3-13
 - CEETSTA (Test for Omitted Argument) 6-5
 - condition management 11-2, 11-3
 - Construct Condition Token (CEENCOD) 8-6
 - control flow 11-2
 - Create Heap (CEECRHP) 7-4, 7-5
 - date 11-2
 - debugger 11-3
 - Define Heap Allocation Strategy (CEE4DAS) 7-5
 - Discard Heap (CEEDSHP) 7-2, 7-5
 - Dispatch Message (CEEMOUT) 8-9
 - dynamic screen manager (DSM) 11-4
 - error handling 11-3
 - exception management 11-2, 11-3
 - Free Storage (CEEFRST) 7-4
 - Get Heap Storage (CEEGTST) 7-4
 - Get Message (CEEMGET) 8-9
 - Get String Information (CEESGI) 6-7
 - Get, Format and Dispatch Message (CEEMSG) 8-9
 - HLL independence 11-1
 - list of 11-2—11-4
 - Mark Heap (CEEMKHP) 7-2, 7-5
 - math 11-2
 - message handling 11-3
 - Move Resume Cursor (CEEMRCR) 8-3
 - naming conventions 11-1
 - original program model (OPM) and ILE 6-8
 - procedure call 11-3
 - program call 11-3
 - Reallocate Storage (CEECZST) 7-4
 - Register User-Written Condition Handler (CEEHDLR) 3-17, 8-1
 - Release Heap (CEERLHP) 7-2, 7-5
 - Retrieve Operational Descriptor Information (CEEDOD) 6-7
 - Signal Condition (CEESGL)
 - condition token 8-6, 8-9
 - description 3-13
 - source debugger 11-3
 - storage management 11-4
 - supplementing HLL-specific run-time library 11-1
 - Test for Omitted Argument (CEETSTA) 6-5
 - time 11-2
 - Unregister User-Written Condition Handler (CEEHDLU) 3-17

- binder 2-8
- binder information listing
 - service program example A-7
- binder language
 - definition 4-10
 - ENDPGMEXP (End Program Export) 4-11
 - ENDPGMEXP (End Program Export)
 - command 4-12
 - error A-9
 - examples 4-13, 4-22
 - EXPORT 4-13
 - EXPORT (Export Symbol) 4-11
 - STRPGMEXP (Start Program Export) 4-11
 - LVLCHK parameter 4-12
 - PGMLVL parameter 4-12
 - SIGNATURE parameter 4-12
 - STRPGMEXP (Start Program Export)
 - command 4-12
- binder listing
 - basic A-1
 - extended A-3
 - full A-5
 - service program example A-7
- binding
 - benefit of ILE 1-1
 - original program model (OPM) 1-8
- binding directory
 - CL (control language) commands C-1
 - definition 2-7
- binding statistics
 - service program example A-8
- BNDDIR parameter on UPDPMGM command 4-23
- BNDDIR parameter on UPDSRVPGM command 4-23
- BNDSRVPGM parameter on UPDPMGM command 4-23
- BNDSRVPGM parameter on UPDSRVPGM
 - command 4-23
- by reference, passing arguments 6-4
- by value directly, passing arguments 6-3
- by value indirectly, passing arguments 6-3

C

- C environment 1-6
- C signal
 - ILE C/400 3-13
- call
 - procedure 2-10, 6-1
 - procedure pointer 6-1
 - program 2-10, 6-1
- call message queue 3-12
- call stack
 - activation group example 3-2
 - definition 6-1
 - example
 - dynamic program calls 6-1
 - static procedure calls 6-1
- call-level scoping 3-20
- callable service
 - See bindable API (application programming interface)
- Case component of condition token 8-6
- CEE4ABN (Abnormal End) bindable API 8-5
- CEE4DAS (Define Heap Allocation Strategy) bindable API 7-5
- CEE9901 (generic failure) exception message 3-15
- CEECRHP (Create Heap) bindable API 7-4, 7-5
- CEECZST (Reallocate Storage) bindable API 7-4
- CEEDOD (Retrieve Operational Descriptor Information) bindable API 6-7
- CEEDSHP (Discard Heap) bindable API 7-2, 7-5
- CEEFRST (Free Storage) bindable API 7-4
- CEEGTST (Get Heap Storage) bindable API 7-4
- CEEHDLR (Register User-Written Condition Handler) bindable API 3-17, 8-1
- CEEHDLU (Unregister User-Written Condition Handler) bindable API 3-17
- CEEMGET (Get Message) bindable API 8-9
- CEEMKHP (Mark Heap) bindable API 7-2, 7-5
- CEEMOUT (Dispatch Message) bindable API 8-9
- CEEMRCR (Move Resume Cursor) bindable API 8-3
- CEEMSG (Get, Format and Dispatch Message) bindable API 8-9
- CEENCOD (Construct Condition Token) bindable API 8-6
- CEERLHP (Release Heap) bindable API 7-2, 7-5
- CEESGI (Get String Information) bindable API 6-7
- CEESGL (Signal Condition) bindable API
 - condition token 8-6, 8-9
 - description 3-13
- CEETSTA (Test for Omitted Argument) bindable API 6-5
- Change Exception Message (QMHCHGEM) API 8-3
- Change Module (CHGMOD) command 9-2
- CHGMOD (Change Module) command 9-2
- CL (control language) command
 - CHGMOD (Change Module) 9-2
 - RCLACTGRP (Reclaim Activation Group) 5-4
 - RCLRSC (Reclaim Resources)
 - for ILE programs 5-4
 - for OPM programs 5-4
- code optimization
 - errors B-1
 - levels 9-2
 - performance
 - compared to original program model (OPM) 1-6
 - levels 2-14
 - module observability 9-1
- coexistence with existing applications 1-3
- command, CL
 - CALL (dynamic program call) 6-5
 - CHGMOD (Change Module) 9-2
 - CRTPGM (Create Program) 4-1

- command, CL (*continued*)
 - CRTSRVPGM (Create Service Program) 4-1
 - ENDCMTCTL (End Commitment Control) 10-3
 - OPNDBF (Open Data Base File) 10-1
 - OPNQRYF (Open Query File) 10-1
 - RCLACTGRP (Reclaim Activation Group) 3-7
 - RCLRSC (Reclaim Resources) 5-2
 - STRCMTCTL (Start Commitment Control) 10-1, 10-3
 - STRDBG (Start Debug) 9-1
 - Update Program (UPDPGM) 4-22
 - Update Service Program (UPDSRVPGM) 4-22
- command, CL (control language)
 - CHGMOD (Change Module) 9-2
 - RCLACTGRP (Reclaim Activation Group) 5-4
 - RCLRSC (Reclaim Resources)
 - for ILE programs 5-4
 - for OPM programs 5-4
- commitment control
 - activation group 10-3
 - commit operation 10-2
 - commitment definition 10-3
 - ending 10-4
 - example 1-4
 - rollback operation 10-2
 - scope 10-2, 10-3
 - transaction 10-2
- commitment definition 10-1, 10-3
- Common Programming Interface (CPI) Communication, data management 10-2
- component
 - reusable
 - benefit of ILE 1-2
- condition
 - definition 3-19
 - management 8-1
 - bindable APIs (application programming interfaces) 11-2, 11-3
 - relationship to OS/400 message 8-8
- Condition ID component of condition token 8-6
- condition token
 - Case component 8-6
 - Condition ID component 8-6
 - Control component 8-7
 - definition 3-19, 8-6
 - Facility ID component 8-7
 - feedback code on call to bindable API 8-9
 - layout 8-6
 - Message Number component 8-7
 - Message Severity component 8-7
 - Msg_No component 8-7
 - Msg_Sev component 8-7
 - relationship to OS/400 message 8-8
 - Severity component 8-7
 - testing 8-8
- Construct Condition Token (CEENCOD) bindable API 8-6
- control boundary
 - activation group
 - example 3-10
 - default activation group example 3-11
 - definition 3-10
 - function check at 8-4
 - unhandled exception at 8-4
 - use 3-11
- Control component of condition token 8-7
- control flow
 - bindable APIs (application programming interfaces) 11-2
- CPF9999 (function check) exception message 3-14
- Create Heap (CEECRHP) bindable API 7-4, 7-5
- Create Program (CRTPGM) command
 - ACTGRP (activation group) parameter
 - activation group creation 3-5
 - program activation 3-2, 3-5
 - ALWUPD (Allow Update) parameter 4-22, 4-23
 - BNDDIR parameter 4-3
 - compared to CRTSRVPGM (Create Service Program) command 4-1
 - DETAIL parameter
 - *BASIC value A-1
 - *EXTENDED value A-3
 - *FULL value A-5
 - ENTMOD (entry module) parameter 4-8
 - MODULE parameter 4-3
 - output listing A-1
 - program creation 2-3
 - service program activation 3-9
- Create Service Program (CRTSRVPGM) command
 - ACTGRP (activation group) parameter
 - *CALLER value 5-4
 - program activation 3-2, 3-5
 - ALWUPD (Allow Update) parameter 4-23
 - BNDDIR parameter 4-3
 - compared to CRTPGM (Create Program) command 4-1
 - DETAIL parameter
 - *BASIC value A-1
 - *EXTENDED value A-3
 - *FULL value A-5
 - EXPORT parameter 4-9, 4-10
 - MODULE parameter 4-3
 - output listing A-1
 - service program activation 3-9
 - SRCFILE (source file) parameter 4-10
 - SRCMBR (source member) parameter 4-10
- creation of
 - debug data 9-2
 - module 4-25
 - program 4-1, 4-25
 - program activation 3-2

- creation of (*continued*)
 - service program 4-25
- cross-reference listing
 - service program example A-8
- CRTPGM
 - BNDSRVPGM parameter 4-3
- CRTPGM (Create Program) command
 - compared to CRTSRVPGM (Create Service Program) command 4-1
 - DETAIL parameter
 - *BASIC value A-1
 - *EXTENDED value A-3
 - *FULL value A-5
 - ENTMOD (entry module) parameter 4-8
 - output listing A-1
 - program creation 2-3
- CRTSRVPGM
 - BNDSRVPGM parameter 4-3
- CRTSRVPGM (Create Service Program) command
 - ACTGRP (activation group) parameter
 - *CALLER value 5-4
 - compared to CRTPGM (Create Program) command 4-1
 - DETAIL parameter
 - *BASIC value A-1
 - *EXTENDED value A-3
 - *FULL value A-5
 - EXPORT parameter 4-9, 4-10
 - output listing A-1
 - SRCFILE (source file) parameter 4-10
 - SRCMBR (source member) parameter 4-10
- cursor
 - handle 8-1
 - resume 8-1

D

- data compatibility 6-6
- data links 10-2
- data management scoping
 - activation group level 3-20
 - activation-group level 10-3
 - call level 3-20, 5-2
 - commitment definition 10-1
 - Common Programming Interface (CPI) Communication 10-2
 - hierarchical file system 10-2
 - job-level 3-21, 10-3
 - local SQL (Structured Query Language) cursor 10-1
 - open data link 10-2
 - open file management 10-2
 - open file operation 10-1
 - override 10-1
 - remote SQL (Structured Query Language) connection 10-2
 - resource 10-1
- data management scoping (*continued*)
 - rules 3-19
 - SQL (Structured Query Language) cursors 10-1
 - user interface manager (UIM) 10-2
- data sharing
 - original program model (OPM) 1-8
- date
 - bindable APIs (application programming interfaces) 11-2
- debug data
 - creation 9-2
 - definition 2-2
 - removal 9-2
- debug mode
 - addition of programs 9-1
 - definition 9-1
- debugger
 - bindable APIs (application programming interfaces) 11-3
 - CL (control language) commands C-2
 - considerations 9-1
 - description 2-15
- debugging
 - across jobs 9-3
 - bindable APIs (application programming interfaces) 11-3
 - CCSID 290 9-3
 - CCSID 65535 and device CHRID 290 9-3
 - CL (control language) commands C-2
 - error handling 9-3
 - ILE program 2-4
 - module view 9-2
 - national language support
 - restriction 9-3
 - observability 9-1
 - optimization 9-1
 - unmonitored exception 9-3
- default activation group
 - control boundary example 3-11
 - original program model (OPM) and ILE programs 3-5
- default exception handling
 - compared to original program model (OPM) 3-14
- default heap 7-2
- default heap allocation strategy 7-4
- Define Heap Allocation Strategy (CEE4DAS) bindable API 7-5
- deletion
 - activation group 3-6
- direct monitor
 - exception handler type 3-16, 8-1
- Discard Heap (CEEDSHP) bindable API 7-2, 7-5
- Dispatch Message (CEEMOUT) bindable API 8-9
- DSM (dynamic screen manager)
 - bindable APIs (application programming interfaces) 11-4

- dynamic binding
 - original program model (OPM) 1-8
- dynamic program call
 - activation 6-5
 - CALL CL (control language) command 6-5
 - call stack 6-1
 - definition 2-10
 - examples 2-10
 - Extended Program Model (EPM) 6-5
 - original program model (OPM) 1-7, 6-5
 - program activation 3-2
 - service program activation 3-8
- dynamic screen manager (DSM)
 - bindable APIs (application programming interfaces) 11-4
- dynamic storage 7-1

E

- End Commitment Control (ENDCMTCTL)
 - command 10-3
- End Program Export (ENDPGMEXP) command 4-12
- End Program Export (ENDPGMEXP), binder language 4-11
- ENDCMTCTL (End Commitment Control)
 - command 10-3
- ENDPGMEXP (End Program Export), binder language 4-11
- ENTMOD (entry module) parameter 4-8
- entry point
 - compared to ILE program entry procedure (PEP) 2-2
 - Extended Program Model (EPM) 1-8
 - original program model (OPM) 1-7
- EPM (Extended Program Model) 1-8
- error
 - binder language A-9
 - during optimization B-1
- error handling
 - architecture 2-13, 3-12
 - bindable APIs (application programming interfaces) 11-2, 11-3
 - debug mode 9-3
 - default action 3-14, 8-4
 - language specific 3-14
 - nested exception 8-5
 - priority example 3-17
 - recovery 3-14
 - resume point 3-14
- error message
 - MCH3203 4-2
 - MCH4439 4-2
- Escape (*ESCAPE) exception message type 3-13
- exception handler
 - priority example 3-17
 - types 3-16
- exception handling
 - architecture 2-13, 3-12
 - bindable APIs (application programming interfaces) 11-2, 11-3
 - debug mode 9-3
 - default action 3-14, 8-4
 - language specific 3-14
 - nested exception 8-5
 - priority example 3-17
 - recovery 3-14
 - resume point 3-14
- exception management 8-1
- exception message
 - C signal 3-13
 - CEE9901 (generic failure) 3-15
 - CPF9999 (function check) 3-14
 - debug mode 9-3
 - function check (CPF9999) 3-14
 - generic failure (CEE9901) 3-15
 - handling 3-14
 - ILE C/400 raise() function 3-13
 - OS/400 3-13
 - percolation 3-15
 - relationship of ILE conditions to 8-8
 - sending 3-13
 - types 3-13
 - unmonitored 9-3
- exception message architecture
 - error handling 3-12
- export
 - definition 2-2
 - order 4-3
 - strong A-7
 - weak A-7
- EXPORT (Export Symbol) 4-13
- EXPORT (Export Symbol), binder language 4-11
- EXPORT parameter
 - service program signature 4-9
 - used with SRCFILE (source file) and SRCMBR (source member) parameters 4-10
- Export Symbol (EXPORT), binder language 4-11
- exports
 - strong 4-8
 - weak 4-8
- extended listing A-3
- Extended Program Model (EPM) 1-8
- external message queue 3-12

F

- Facility ID component of condition token 8-7
- feedback code option
 - call to bindable API 8-9
- file system, data management 10-2
- Free Storage (CEEFRST) bindable API 7-4

full listing A-5
function check
 (CPF9999) exception message 3-14
 control boundary 8-4
 exception message type 3-13

G

generic failure (CEE9901) exception message 3-15
Get Heap Storage (CEEGTST) bindable API 7-4
Get Message (CEEMGET) bindable API 8-9
Get String Information (CEESGI) bindable API 6-7
Get, Format and Dispatch Message (CEEMSG)
 bindable API 8-9
Glossary G-1

H

handle cursor
 definition 8-1
heap
 allocation strategy
 _CEE4ALC allocation strategy type 7-4
 default 7-4
 characteristics 7-1
 default heap 7-2
 definition 7-1
 ILE C/400 heap support 7-3
 single-heap support 7-3
 user-created heap 7-2
history of ILE 1-6
HLL specific
 error handling 3-14
 exception handler 3-17, 8-1
 exception handling 3-14

I

ILE
 basic concepts 2-1
 compared to
 Extended Program Model (EPM) 1-10
 original program model (OPM) 1-10, 2-1
 definition 1-1
 history 1-6
 introduction 1-1
 program structure 2-1
ILE condition handler
 exception handler type 3-16, 8-1
import
 definition 2-2
 procedure 2-4
 resolved and unresolved 4-2
important parameters on UPDPGM and UPDSRVPGM
 commands 4-23

interlanguage data compatibility 6-6

J

job
 multiple applications running in same 5-1
job message queue 3-12
job-level scoping 3-21

L

language
 procedure-based
 characteristics 1-9
language interaction
 consistent error handling 3-15
 control 1-4
 data compatibility 6-6
language specific
 error handling 3-14
 exception handler 3-17, 8-1
 exception handling 3-14
level check parameter on STRPGMEXP
 command 4-12
level number 5-2
listing, binder
 basic A-1
 extended A-3
 full A-5
 service program example A-7

M

Mark Heap (CEEMKHP) bindable API 7-2, 7-5
math
 bindable APIs (application programming
 interfaces) 11-2
MCH3203 error message 4-2
MCH4439 error message 4-2
message
 bindable API feedback code 8-9
 exception types 3-13
 queue 3-12
 relationship of ILE conditions to 8-8
message handling
 bindable APIs (application programming
 interfaces) 11-3
Message Number (Msg_No) component of condition
 token 8-7
message queue
 job 3-12
Message Severity (Msg_Sev) component of condition
 token 8-7
modularity
 benefit of ILE 1-1

- module object
 - CL (control language) commands C-1
 - creation tips 4-25
 - description 2-2
- MODULE parameter on UPDPGM command 4-23
- MODULE parameter on UPDSRVPGM command 4-23
- module replaced by module
 - fewer exports 4-24
 - fewer imports 4-24
 - more exports 4-25
 - more imports 4-24
- module replacement 4-22
- module view
 - debugging 9-2
- Move Resume Cursor (CEEMRCR) bindable API 8-3
- multiple applications running in same job 5-1

N

- national language support restriction for debugging 9-3
- nested exception 8-5
- Notify (*NOTIFY) exception message type 3-13

O

- observability 9-1, 9-2
- ODP (open data path)
 - scoping 3-19
- omitted argument 6-5
- Open Data Base File (OPNDBF) command 10-1
- open data path (ODP)
 - scoping 3-19
- open file operations 10-1
- Open Query File (OPNQRYF) command 10-1
- operational descriptor 6-6—6-7
- OPM (original program model)
 - activation group 3-5
 - binding 1-8
 - characteristics 1-8
 - compared to ILE 2-1, 2-3
 - data sharing 1-8
 - default exception handling 3-14
 - description 1-7
 - dynamic binding 1-8
 - dynamic program call 1-7, 6-5
 - entry point 1-7
 - exception handler types 3-16
 - program entry point 1-7
- OPNDBF (Open Data Base File) command 10-1
- OPNQRYF (Open Query File) command 10-1
- optimization
 - benefit of ILE 1-6
 - code
 - levels 2-14
 - module observability 9-1
 - errors B-1

- optimization (*continued*)
 - levels 9-2
- optimizing translator 1-6, 2-14
- original program model (OPM)
 - activation group 3-5
 - binding 1-8
 - characteristics 1-8
 - compared to ILE 2-1, 2-3
 - data sharing 1-8
 - default exception handling 3-14
 - description 1-7
 - dynamic binding 1-8
 - dynamic program call 1-7, 6-5
 - entry point 1-7
 - exception handler types 3-16
 - program entry point 1-7
- OS/400 exception message 3-13, 8-8
- output listing
 - Create Program (CRTPGM) command A-1
 - Create Service Program (CRTSRVPGM) command A-1
 - Update Program (UPDPGM) command A-1
 - Update Service Program (UPDSRVPGM) command A-1
- override, data management 10-1

P

- passing arguments
 - between languages 6-6
 - by reference 6-4
 - by value directly 6-3
 - by value indirectly 6-3
 - in mixed-language applications 6-6
 - omitted arguments 6-5
 - to procedures 6-3
 - to programs 6-6
- PEP (program entry procedure)
 - call stack example 6-1
 - definition 2-2
 - specifying with CRTPGM (Create Program) command 4-8
- percolation
 - exception message 3-15
- performance
 - optimization
 - benefit of ILE 1-6
 - errors B-1
 - levels 2-14, 9-2
 - module observability 9-1
- priority
 - exception handler example 3-17
- procedure
 - definition 1-8, 2-2
 - passing arguments to 6-3

- procedure call
 - bindable APIs (application programming interfaces) 11-3
 - compared to program call 2-10, 6-1
 - Extended Program Model (EPM) 6-5
 - static
 - call stack 6-1
 - definition 2-10
 - examples 2-11
- procedure pointer call 6-1, 6-3
- procedure-based language
 - characteristics 1-9
- program
 - access 4-8
 - activation 3-1
 - CL (control language) commands C-1
 - comparison of ILE and original program model (OPM) 2-3
 - creation
 - examples 4-5, 4-7
 - process 4-1
 - tips 4-25
 - passing arguments to 6-6
- program activation
 - activation 3-2
 - creation 3-2
 - dynamic program call 3-2
- program call
 - bindable APIs (application programming interfaces) 11-3
 - call stack 6-1
 - compared to procedure call 6-1
 - definition 2-10
 - examples 2-10
- program entry point
 - compared to ILE program entry procedure (PEP) 2-2
 - Extended Program Model (EPM) 1-8
 - original program model (OPM) 1-7
- program entry procedure (PEP)
 - call stack example 6-1
 - definition 2-2
 - specifying with CRTPGM (Create Program) command 4-8
- program isolation in activation groups 3-3
- program level parameter on STRPGMEXP command 4-12
- program structure 2-1
- program update 4-22
 - module replaced by module
 - fewer exports 4-24
 - fewer imports 4-24
 - more exports 4-25
 - more imports 4-24
- Promote Message (QMHPRMM) API 8-4

Q

- QCAPCMD API 5-4
- QMHCHGEM (Change Exception Message) API 8-3
- QMHPRMM (Promote Message) API 8-4
- QMHSNDPM (Send Program Message) API 3-13, 8-1
- QUSRTOOL library
 - QATTINFO file
 - TBNINFO member 4-11, 4-25

R

- raise() function
 - ILE C/400 3-13
- RCLACTGRP (Reclaim Activation Group)
 - command 3-7, 5-4
- RCLRSC (Reclaim Resources) command 5-2
 - for ILE programs 5-4
 - for OPM programs 5-4
- Reallocate Storage (CEEZST) bindable API 7-4
- Reclaim Activation Group (RCLACTGRP)
 - command 3-7, 5-4
- Reclaim Resources (RCLRSC) command 5-2
 - for ILE programs 5-4
 - for OPM programs 5-4
- recovery
 - exception handling 3-14
- register exception handler 3-17
- Register User-Written Condition Handler (CEEHDLR)
 - bindable API 3-17, 8-1
- Release Heap (CEERLHP) bindable API 7-2, 7-5
- removal of debug data 9-2
- resolved import 4-2
- resolving symbol
 - description 4-2
 - examples 4-5, 4-7
- resource control 1-3
- resource isolation in activation groups 3-3
- resource, data management 10-1
- restriction
 - debugging
 - national language support 9-3
- resume cursor
 - definition 8-1
 - exception recovery 3-14
- resume point
 - exception handling 3-14
- Retrieve Operational Descriptor Information (CEEDOD)
 - bindable API 6-7
- reuse
 - activation group 3-6
 - components 1-2
- rollback operation
 - commitment control 10-2
- RPLLIB parameter on UPDPGM command 4-23

RPLLIB parameter on UPDSRVPGM command 4-23
run-time services 1-2

S

scope

commitment control 10-3

scoping, data management

activation group level 3-20

activation-group level 10-3

call level 3-20, 5-2

commitment definition 10-1

Common Programming Interface (CPI) Communication 10-2

hierarchical file system 10-2

job level 3-21

job-level 10-3

local SQL (Structured Query Language) cursor 10-1

open data link 10-2

open file management 10-2

open file operation 10-1

override 10-1

remote SQL (Structured Query Language) connection 10-2

resource 10-1

rules 3-19

SQL (Structured Query Language) cursors 10-1

user interface manager (UIM) 10-2

Send Program Message (QMHSNDPM) API 3-13, 8-1

sending

exception message 3-13

service program

activation 3-8, 6-2

binder listing example A-7

CL (control language) commands C-1

creation tips 4-25

definition 2-5

description 1-10

signature 4-9, 4-11

static procedure call 6-2

Severity component of condition token 8-7

shared open data path (ODP) example 1-3

Signal Condition (CEESGL) bindable API

condition token 8-6, 8-9

description 3-13

signature 4-11

EXPORT parameter 4-9

signature parameter on STRPGMEXP command 4-12

source debugger 1-3

bindable APIs (application programming interfaces) 11-3

CL (control language) commands C-2

considerations 9-1

description 2-15

SQL (Structured Query Language)

CL (control language) commands C-2

SQL (Structured Query Language) (*continued*)

connections, data management 10-2

SRCFILE (source file) parameter 4-10

SRCMBR (source member) parameter 4-10

stack, call 6-1

Start Commitment Control (STRCMTCTL)

command 10-1, 10-3

Start Debug (STRDBG) command 9-1

Start Program Export (STRPGMEXP) command 4-12

Start Program Export (STRPGMEXP), binder language 4-11

static procedure call

call stack 6-1

definition 2-10

examples 2-11, 6-3

service program 6-2

service program activation 3-9

static storage 7-1

static variable 3-1, 5-1

Status (*STATUS) exception message type 3-13

storage management

automatic storage 7-1

bindable APIs 7-4

bindable APIs (application programming interfaces) 11-4

dynamic storage 7-1

heap 7-1

static storage 5-2, 7-1

storage manager 7-1

STRCMTCTL (Start Commitment Control)

command 10-1, 10-3

STRDBG (Start Debug) command 9-1

strong export A-7

strong exports 4-8

STRPGMEXP (Start Program Export), binder language 4-11

structure of ILE program 2-1

Structured Query Language (SQL)

CL (control language) commands C-2

connections, data management 10-2

support for original program model (OPM) and ILE APIs 6-8

symbol resolution

definition 4-2

examples 4-5, 4-7

system-named activation group 3-5, 3-7

T

TBNINFO member

QATTINFO file, QUSRTOOL library 4-11, 4-25

Test for Omitted Argument (CEETSTA) bindable API 6-5

testing condition token 8-8

time

bindable APIs (application programming interfaces) 11-2

- tip
 - module, program and service program creation 4-25
- transaction
 - commitment control 10-2
- translator
 - code optimization 1-6, 2-14

U

- UEP (user entry procedure)
 - call stack example 6-1
 - definition 2-2
- unhandled exception
 - default action 3-14
- unmonitored exception 9-3
- Unregister User-Written Condition Handler (CEEHDLU)
 - bindable API 3-17
- unresolved import 4-2
- Update Program (UPDPGM) command 4-22
- Update Service Program (UPDSRVPGM)
 - command 4-22
- UPDPGM command
 - BNDDIR parameter 4-23
 - BNDSRVPGM parameter 4-23
 - MODULE parameter 4-23
 - RPLLIB parameter 4-23
- UPDSRVPGM command
 - BNDDIR parameter 4-23
 - BNDSRVPGM parameter 4-23
 - MODULE parameter 4-23
 - RPLLIB parameter 4-23
- user entry procedure (UEP)
 - call stack example 6-1
 - definition 2-2
- user interface manager (UIM), data management 10-2
- user-named activation group
 - deletion 3-7
 - description 3-4, 5-1

V

- variable
 - static 3-1, 5-1

W

- weak export A-7
- weak exports 4-8

Reader Comments—We'd Like to Hear from You!

AS/400
 Integrated Language Environment
 Concepts
 Version 3

Publication No. SC41-3606-00

Overall, how would you rate this manual?

	Very Satisfied	Satisfied	Dissatisfied	Very Dissatisfied
Overall satisfaction				

How satisfied are you that the information in this manual is:

Accurate				
Complete				
Easy to find				
Easy to understand				
Well organized				
Applicable to your tasks				
THANK YOU!				

Please tell us how we can improve this manual:

May we contact you to discuss your responses? Yes No

Phone: (____) _____ Fax: (____) _____

To return this form:

- Mail it
- Fax it
 - United States and Canada: **800+937-3430**
 - Other countries: **(+1)+507+253-5192**
- Hand it to your IBM representative.

Note that IBM may use or distribute the responses to this form without obligation.

 Name

 Address

 Company or Organization

 Phone No.



Fold and Tape

Please do not staple

Fold and Tape



NO POSTAGE
NECESSARY
IF MAILED IN THE
UNITED STATES

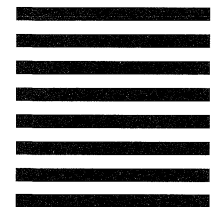

BUSINESS REPLY MAIL

FIRST-CLASS MAIL PERMIT NO. 40 ARMONK, NEW YORK

POSTAGE WILL BE PAID BY ADDRESSEE

ATTN DEPT 245
IBM CORPORATION
3605 HWY 52 N
ROCHESTER MN 55901-9986



Fold and Tape

Please do not staple

Fold and Tape

Reader Comments—We'd Like to Hear from You!

AS/400
 Integrated Language Environment
 Concepts
 Version 3

Publication No. SC41-3606-00

Overall, how would you rate this manual?

	Very Satisfied	Satisfied	Dissatisfied	Very Dissatisfied
Overall satisfaction				

How satisfied are you that the information in this manual is:

Accurate				
Complete				
Easy to find				
Easy to understand				
Well organized				
Applicable to your tasks				
THANK YOU!				

Please tell us how we can improve this manual:

May we contact you to discuss your responses? Yes No

Phone: (____) _____ Fax: (____) _____

To return this form:

- Mail it
- Fax it
- United States and Canada: **800+937-3430**
- Other countries: **(+1)+507+253-5192**
- Hand it to your IBM representative.

Note that IBM may use or distribute the responses to this form without obligation.

Name	Address
Company or Organization	
Phone No.	



Fold and Tape

Please do not staple

Fold and Tape



NO POSTAGE
NECESSARY
IF MAILED IN THE
UNITED STATES



BUSINESS REPLY MAIL

FIRST-CLASS MAIL PERMIT NO. 40 ARMONK, NEW YORK

POSTAGE WILL BE PAID BY ADDRESSEE

ATTN DEPT 245
IBM CORPORATION
3605 HWY 52 N
ROCHESTER MN 55901-9986



Fold and Tape

Please do not staple

Fold and Tape

Reader Comments—We'd Like to Hear from You!

AS/400
Integrated Language Environment
Concepts
Version 3

Publication No. SC41-3606-00

Overall, how would you rate this manual?

	Very Satisfied	Satisfied	Dissatisfied	Very Dissatisfied
Overall satisfaction				

How satisfied are you that the information in this manual is:

Accurate				
Complete				
Easy to find				
Easy to understand				
Well organized				
Applicable to your tasks				
THANK YOU!				

Please tell us how we can improve this manual:

May we contact you to discuss your responses? Yes No

Phone: (____) _____ Fax: (____) _____

To return this form:

- Mail it
- Fax it
United States and Canada: **800+937-3430**
Other countries: **(+1)+507+253-5192**
- Hand it to your IBM representative.

Note that IBM may use or distribute the responses to this form without obligation.

Name

Address

Company or Organization

Phone No.



Fold and Tape

Please do not staple

Fold and Tape



NO POSTAGE
NECESSARY
IF MAILED IN THE
UNITED STATES

BUSINESS REPLY MAIL

FIRST-CLASS MAIL PERMIT NO. 40 ARMONK, NEW YORK

POSTAGE WILL BE PAID BY ADDRESSEE

ATTN DEPT 245
IBM CORPORATION
3605 HWY 52 N
ROCHESTER MN 55901-9986

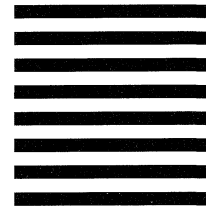

Fold and Tape

Please do not staple

Fold and Tape



Program Number: 5763-SS1

Printed in Denmark by
Scanprint as, Viby J.

SC41-3606-00

